

ISO 1552
PNEUMATIC CYLINDERS
ISO-M SERIES Ø32 - Ø125





ISO-M SERIES

ISO 15552 - Ø32 - Ø125

MAGNETIC CUSHIONING CYLINDER

HIGH TEMPERATURE ENDURANCE,
HIGH DURABILITY

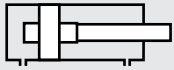

ISO: DOUBLE ACTING CYLINDER WITH CUSHIONING

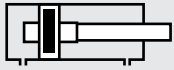

ISO-M: DOUBLE ACTING CYLINDER WITH CUSHIONING AND MAGNETIC

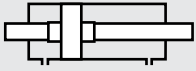

ISO-D: DOUBLE ACTING CYLINDER WITH CUSHIONING AND DOUBLE ROD

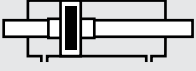

ISO-MD: DOUBLE ACTING CYLINDER WITH CUSHIONING, MAGNETIC AND DOUBLE ROD

Cushioning is standard on these products.

Example of order:

ISO-M

Product Code

050-0100

Cylinder Ø_{Stroke}

SF RC

Cylinder Mountings

R1 K1

Variants from Standard System

VARIANTS FROM STANDARD SYSTEM:

- R1: Stainless Steel Piston Rod (SS 304-SS 316)
- R3: Stainless Steel Screws for Cylinder Covers (SS 304)
- R4: Stainless Steel Nut for Piston Rod (SS 304)
- R5: Piston Rod as CK45 (Hard chrome plated)
- M1: Extended male Piston Rod Thread
- M2: Female Piston Rod Thread
- M3: Special Piston Rod Thread
- M4: Extended Piston Rod
- E1: Hard Eloxal Plated, Anticorrosive Aluminium Covers
- K1: Seals for Max. 150°C (Viton)
- K2: Piston Rod Seal NBR + PA
- K3: Seals NBR
- K4: Piston Rod Seal Viton

Working Fluid:

Filtered and lubricated or filtered and not lubricated air

Operating Temperature Range:

Polyurethane (PU) : (-20°C) - (+80°C)

Viton (FKM) : (-30°C) - (+180°C)

Max. Work Pressure:

10 Bar

Force:

Cylinder Ø mm	Rod Ø mm	Thrust and traction forces (6 Bar)	
		Thrust Force (N)	Traction Force (N)
32	12	482	415
40	16	754	633
50	20	1178	990
63	20	1870	1682
80	25	3016	2721
100	25	4712	4418
125	32	7363	6881

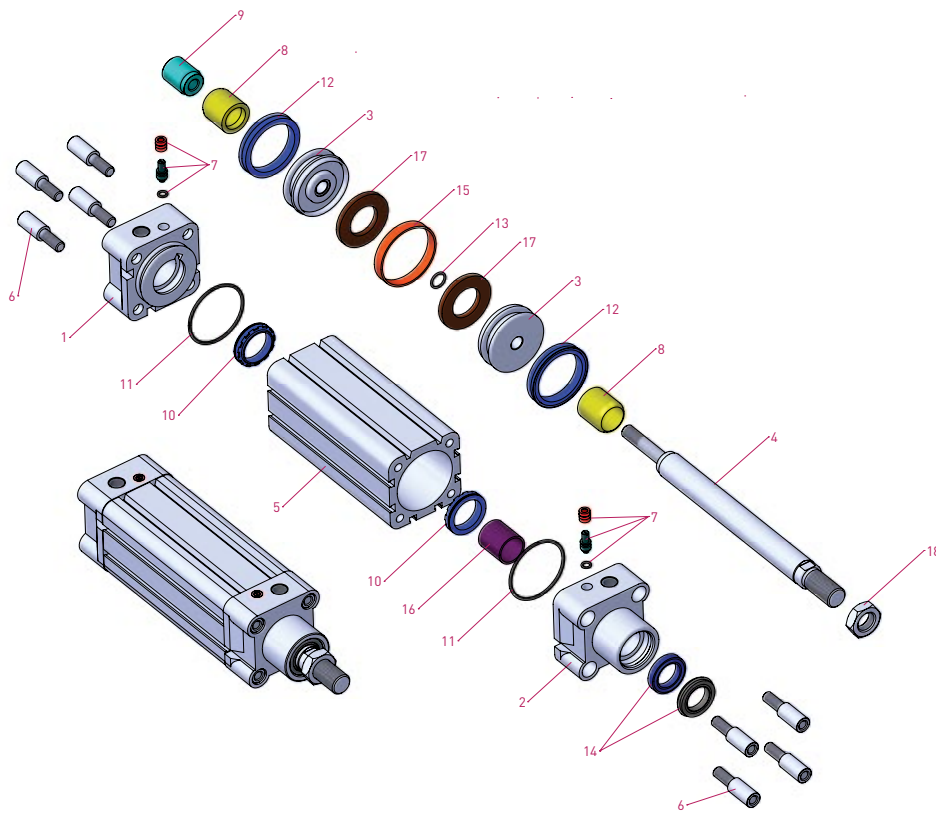
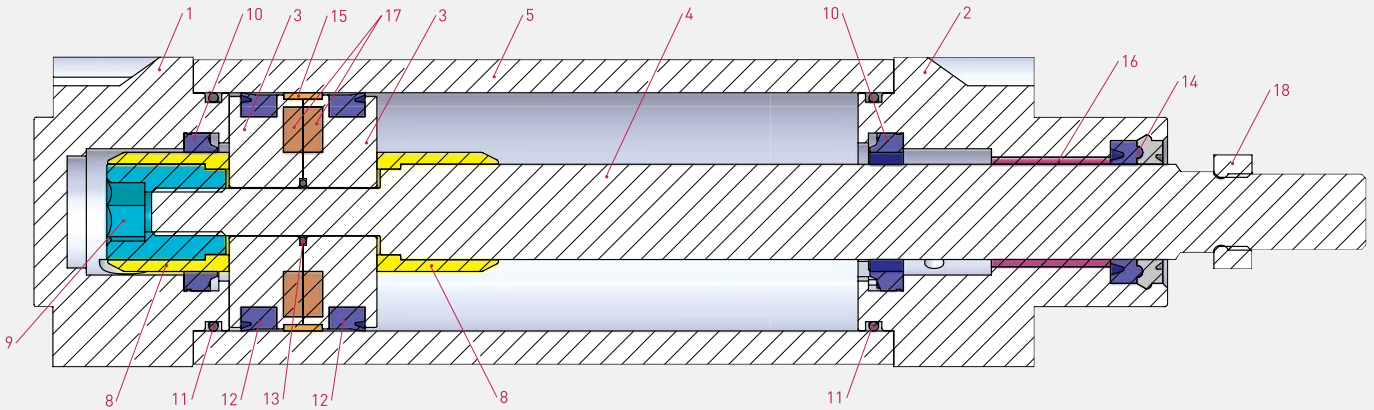

No	MATERIAL NAME	CHARACTERISTIC	PC.
1	Rear Head	Aluminium	1
2	Front Head	Aluminium	1
3	Middle Piston	Aluminium	2
4	Piston Rod	X20 Cr13 Hard Chrome Plated	1
5	Tube	Al Mg Si 0,5 + Eloxal Plated	1
6	Bolt	Galvanized Steel	8
7	Cushioning Screw	6082 Al. + Eloxal + AISI 303 NBR	2
8	Cushioning Plastic	Polyacetal	2
9	Cushioning Fem. Thread	Galvanized Steel	1
10	Cushioning Seal	PU	2
11	Head O-ring	NBR	2

No	MATERIAL NAME	CHARACTERISTIC	PC.
12	Piston Seal	PU	2
13	Middle Piston O-ring	NBR	1
14	Rod Seal	HYTREL + PU	1
15	Guiding Band	Polyacetal	1
16	Guiding Bush	CSB-40	1
17	Magnet		2
18	Nut	Galvanized Steel	1

Note:

Dia 32: Instead of Cushioning Plastic is used Cushioning yellow and instead of Cushioning Plastic Female Thread is used Cushioning yellow Female Thread. (Material:Brass)

Dia 125: Instead of Cushioning Plastic is used Cushioning Aluminium and instead of Cushioning Plastic Female Thread is used Cushioning Aluminium Female Thread. (Material: Anodized Aluminium)

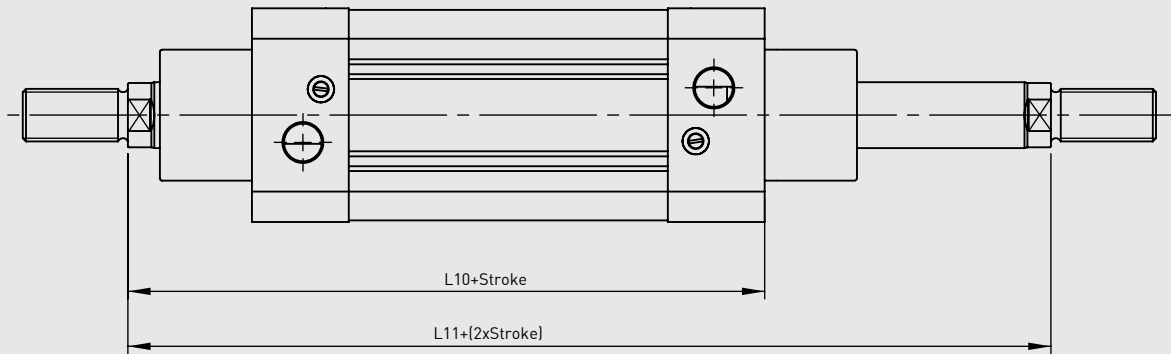
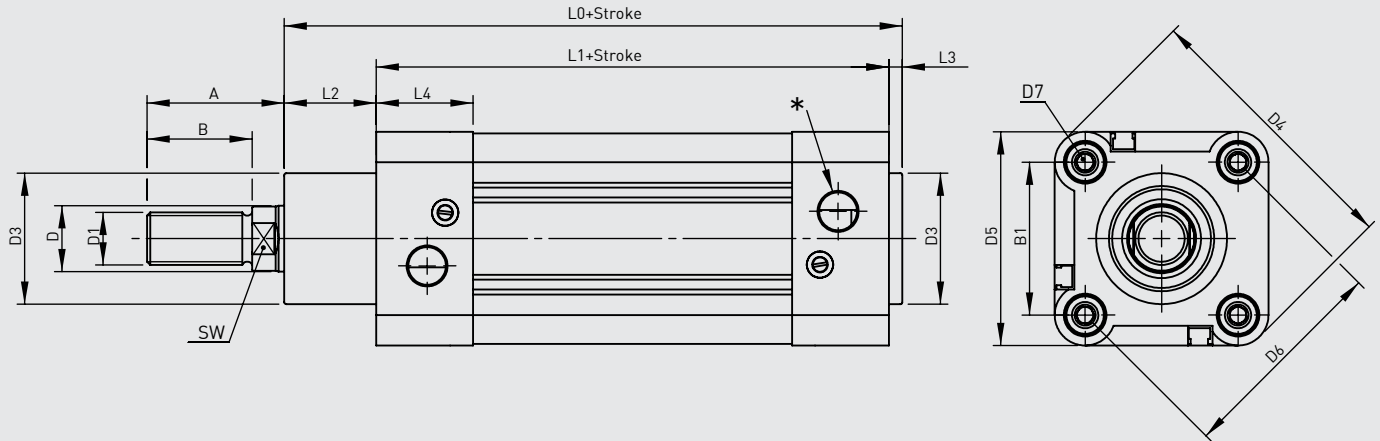

Silindir Ø mm	A	B	B1	D Ø	D1	D3 Ø	D4	D5	D6 Ø	D7	L0	L1	L2	L3	L4	L10	L11	SW	*
32	30	22	32.5	12	M10x1.25	30	59	45	46	M6	116	94	18	4	25	120	146	10	G1/8"
40	34	24	38	16	M12x1.25	35	70.2	54	53.7	M6	129	105	20	4	27	135	165	13	G1/4"
50	41	32	46.5	20	M16x1.5	40	84.2	65	65.7	M8	138	106	28	4	29.5	143	180	17	G1/4"
63	42	32	56.5	20	M16x1.5	45	99.5	76	80	M8	152	121	27	4	34.5	158	195	17	G3/8"
80	52	40	72	25	M20x1.5	45	123.8	94	101.8	M10	167	128	34	4	35	174	220	22	G3/8"
100	52.5	40	89	25	M20x1.5	55	148.8	112	125.9	M10	182.5	138	38.5	4	38	189	240	22	G1/2"
125	73	54	110	32	M27x2	60	179.5	134	155.5	M12	213	160	46	6	44	225	290	27	G1/2"

FLM FLANGE MOUNTING

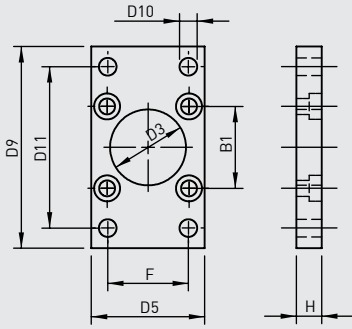

FMF FLANGE MOUNTING AT FRONT

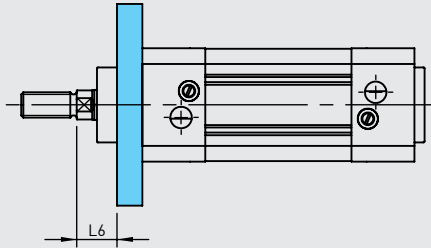

FMTR FLANGE MOUNTING AT REAR

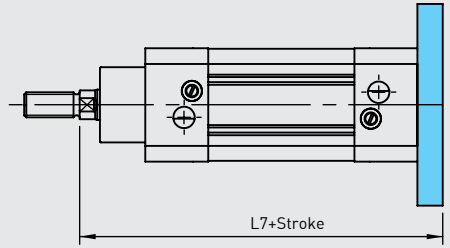

FM FOOT MOUNTING

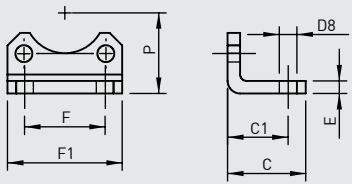

FM FOOT MOUNTING

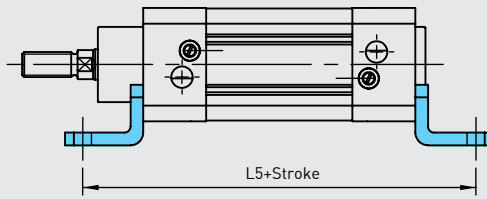

SF SWIVEL FLANGE

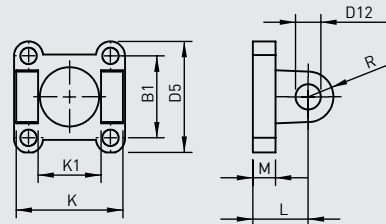

SF SWIVEL FLANGE

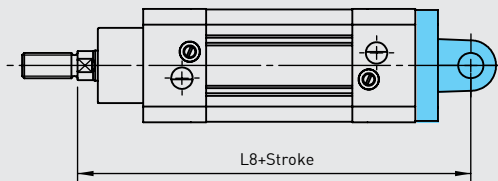

RC ROD CLEVIS

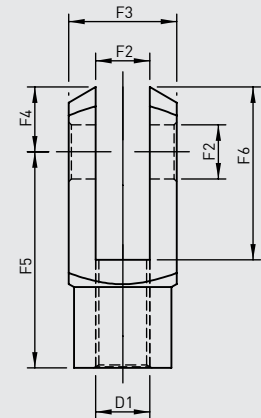

CFM CLEVIS FOOT MOUNTING

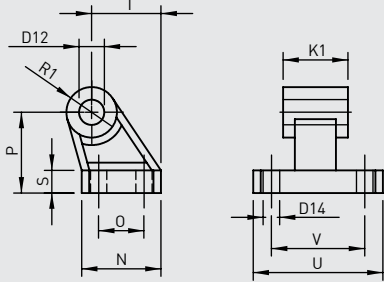

SFWCFM SWIVEL FLANGE WITH CLEVIS FOOT MOUNTING

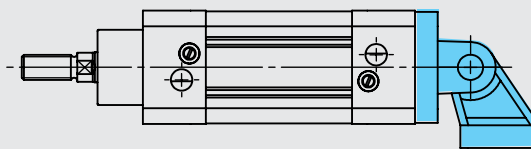

Cylinder Ø mm	B1	C	C1	D1	D3 Ø	D5	D8 Ø	D9	D10 Ø	D11	D12 Ø	D14 Ø	E	F	F1	F2 Ø	F3
32	32.5	30	24	M10x1.25	30	45	7	80	7	64	10	5.5	5	32	45.5	10	20
40	38	37	28	M12x1.25	35	54	10	90	9	72	12	5.5	5	36	54.5	12	24
50	46.5	41	32	M16x1.5	40	65	10	110	9	90	12	6.5	6	45	65	16	32
63	56.5	44	32	M16x1.5	45	76	10	120	9	100	16	6.5	6	50	76	16	32
80	72	56	41	M20x1.5	45	94	12	150	12	126	16	9	6	63	94	20	40
100	89	58	41	M20x1.5	55	112	14	175	14	150	20	9	6	75	112	20	40
125	110	67	45	M27x2	60	134	16	210	16	180	25	11	8	90	131	25	50

Cylinder Ø mm	F4	F5	F6	H	K	K1	L	L5	L6	L7	L8	M	N	O	P	R	R1	S	T	U	V
32	12	40	32	10	45	26	22	142	16	130	142	9	31	18	32	10	10	8	27.5	51	38
40	14	48	38	10	52	28	25	161	20	145	160	9	35	22	36	12	11	10	30.5	54	41
50	19	64	51	12	60	32	27	170	25	155	170	11	45	30	45	13	13	12	40.5	65	50
63	19	64	51	12	70	40	32	185	25	170	190	11	50	35	50	16	15	12	44.5	67	52
80	25	80	65	16	90	50	36	210	30	190	210	14	60	40	63	16	15	14	57	86	66
100	25	80	65	16	110	60	41	220	35	205	230	14	70	50	71	20	19	15	65	96	76
125	32	100	82	20	130	70	50	250	45	245	275	15	90	60	90	25	22.5	20	85	124	94

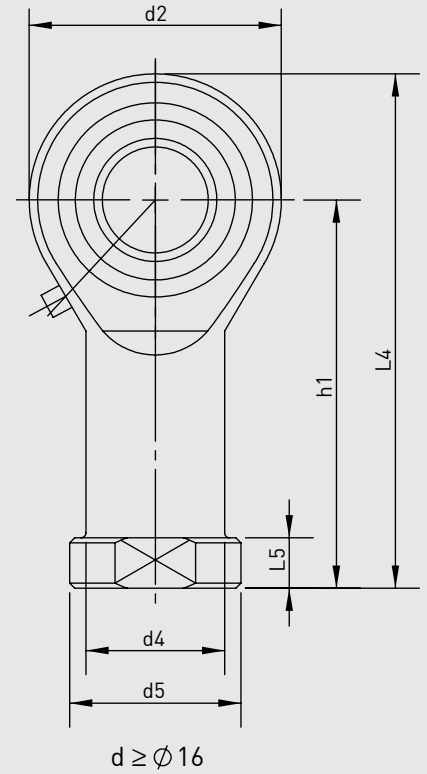
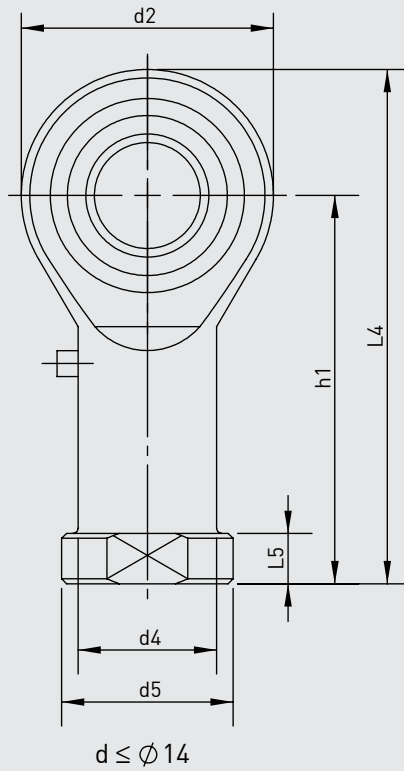
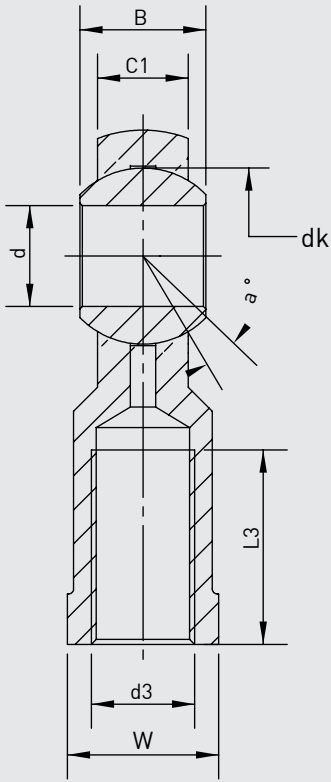

ISO-M SERIES
ISO 15552 - Ø32 - Ø125

Part No.	Dimensions (mm)													
	d	d3 6H	B	C1	w	L3 min	d2	L4	h1	L5	d4	d5	dk	a°
KMB 10-1	10	M10x1.25	14	10.5	17	20	26	56	43	6.5	15	19	19.05	13
KMB 12-1	12	M12x1.25	16	12	19	22	30	65	50	6.5	17.5	22	22.225	13
KMB 16-1	16	M16x1.5	21	15	22	28	40	84	64	8	22	27	28.575	15
KMB 20	20	M20x1.5	25	18	30	33	50	102	77	10	27.5	34	34.925	14
KMB 28	28	M27x2.0	35	24	41	48	66	136	103	14	37	46	47.6	15
KMB 30	30	M30x2.0	37	25	41	51	70	145	110	15	40	50	50.8	17

ISO 15552
PNEUMATIC CYLINDERS
PMT SERIES Ø32 - Ø100





PMT SERIES
ISO 15552 - Ø32 - Ø100

MAGNETIC CUSHIONING CYLINDER

LIGHT-WEIGHT MEETS
HIGH PERFORMANCE

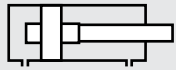

PMT: DOUBLE ACTING CYLINDER WITH CUSHIONING

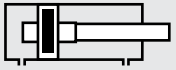

PMT-A: DOUBLE ACTING CYLINDER WITH CUSHIONING AND MAGNETIC

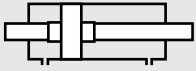

PMT-D: DOUBLE ACTING CYLINDER WITH CUSHIONING AND DOUBLE ROD

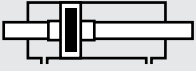

PMT-AD: DOUBLE ACTING CYLINDER WITH CUSHIONING, MAGNETIC AND DOUBLE ROD

Cushioning is standard on these products.

Example of order:

PMT-A **050-0100** **SFWCFM RC** **M4**
 Product Code Cylinder Ø Stroke Cylinder Mountings Variants from Standard System

VARIANTS FROM STANDARD SYSTEM:

- R1: Stainless Steel Piston Rod (SS 304-SS 316)
- R3: Stainless Steel Screws for Cylinder Covers (SS 304)
- R4: Stainless Steel Nut for Piston Rod (SS 304)
- R5: Piston Rod as CK45 (Hard chrome plated)
- M1: Extended male Piston Rod Thread
- M2: Female Piston Rod Thread
- M3: Special Piston Rod Thread
- M4: Extended Piston Rod
- E1: Hard Eloxal Plated, Anticorrosive Aluminium Covers
- K1: Seals for Max. 150°C Viton)
- K2: Piston Rod Seal NBR + PA
- K3: Seals NBR
- K4: Piston Rod Seal Viton

Working Fluid:

Filtered and lubricated or filtered and not lubricated air

Operating Temperature Range:

Polyurethane (PU) : (-20°C) - (+80°C)
 Viton (FKM) : (-30°C) - (+180°C)

Max. Work Pressure:

10 Bar

Force:

Cylinder Ø mm	Rod Ø mm	Thrust and traction forces(6 Bar)	
		ThrustForce (N)	Traction Force (N)
32	12	482	415
40	16	754	633
50	20	1178	990
63	20	1870	1682
80	25	3016	2721
100	25	4712	4418

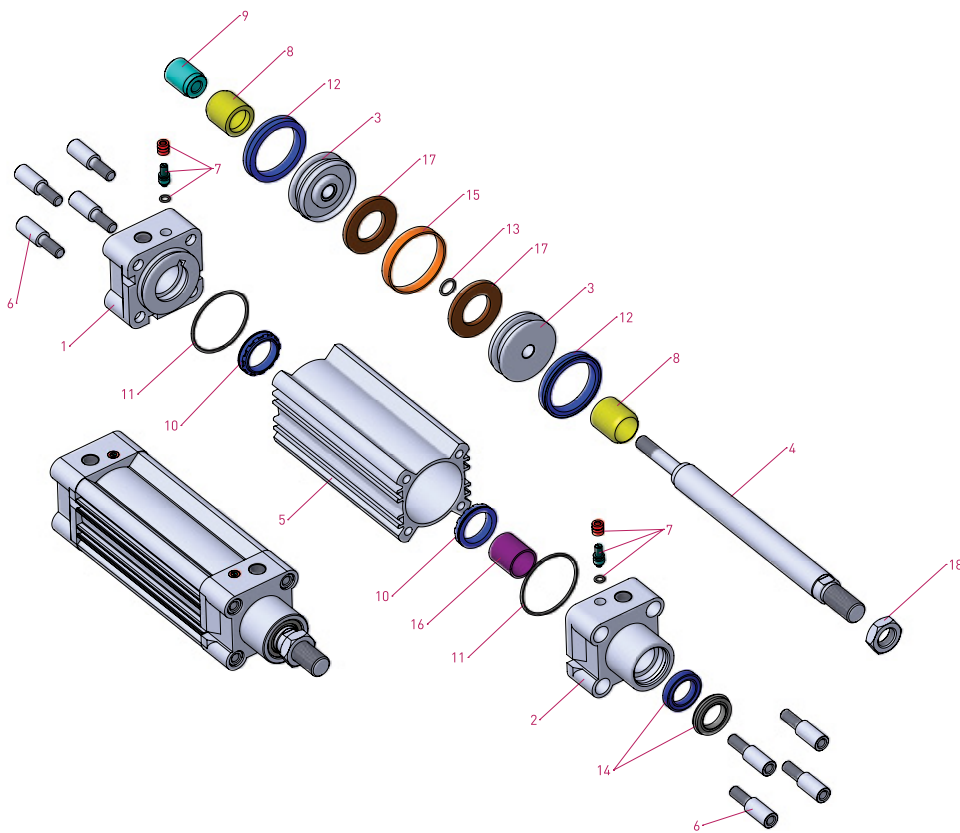
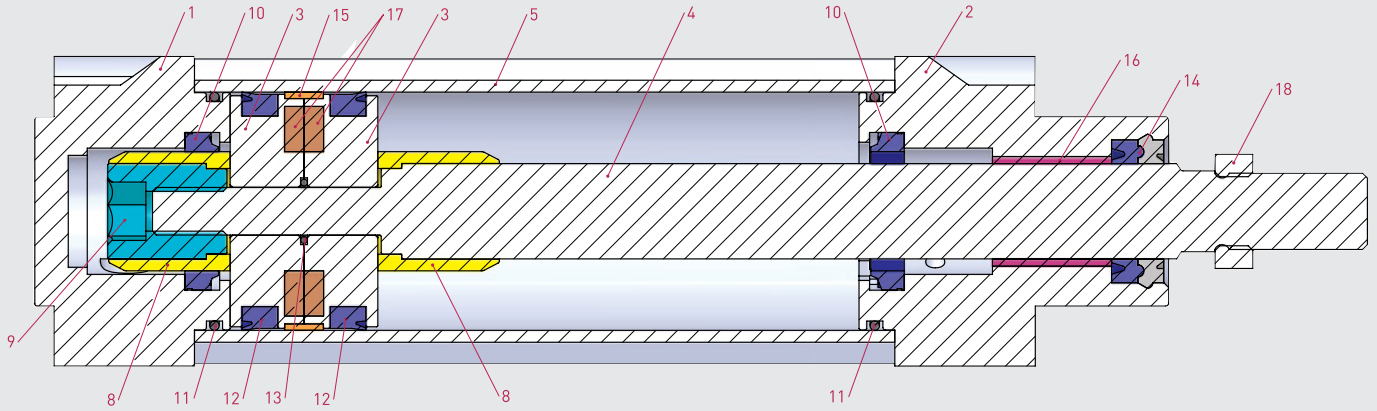

No	MATERIAL NAME	CHARACTERISTIC	PC.
1	Rear Head	Aluminium	1
2	Front Head	Aluminium	1
3	Middle Piston	Aluminium	2
4	Piston Rod	X20 Cr13 Hard Chrome Plated	1
5	Tube	Al Mg Si 0,5 + Eloxal Plated	1
6	Bolt	Galvanized Steel	8
7	Cushioning Screw	6082 AL.+Eloxal+AISI 303 NBR	2
8	Cushioning Plastic	Polyacetal	2
9	Cushioning Fem. Thread	Galvanized Steel	1
10	Cushioning Seal	PU	2
11	Head O-ring	NBR	2

No	MATERIAL NAME	CHARACTERISTIC	PC.
12	Piston Seal	PU	2
13	Middle Piston O-ring	NBR	1
14	Rod Seal	HYTREL + PU	1
15	Guiding Band	Polyacetal	1
16	Guiding Bush	CSB-40	1
17	Magnet		2
18	Nut	Galvanized Steel	1

Note:

Dia 32: Instead of Cushioning Plastic is used Cushioning yellow and instead of Cushioning Plastic Female Thread is used Cushioning yellow Female Thread. (Material:Brass)

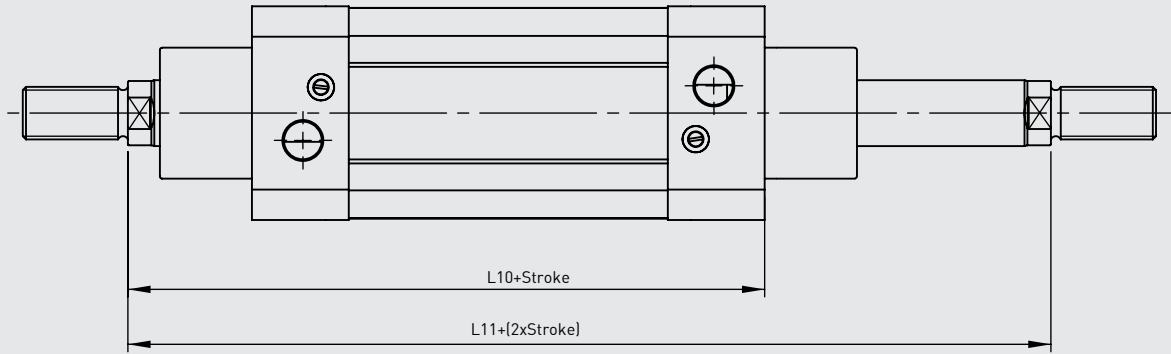
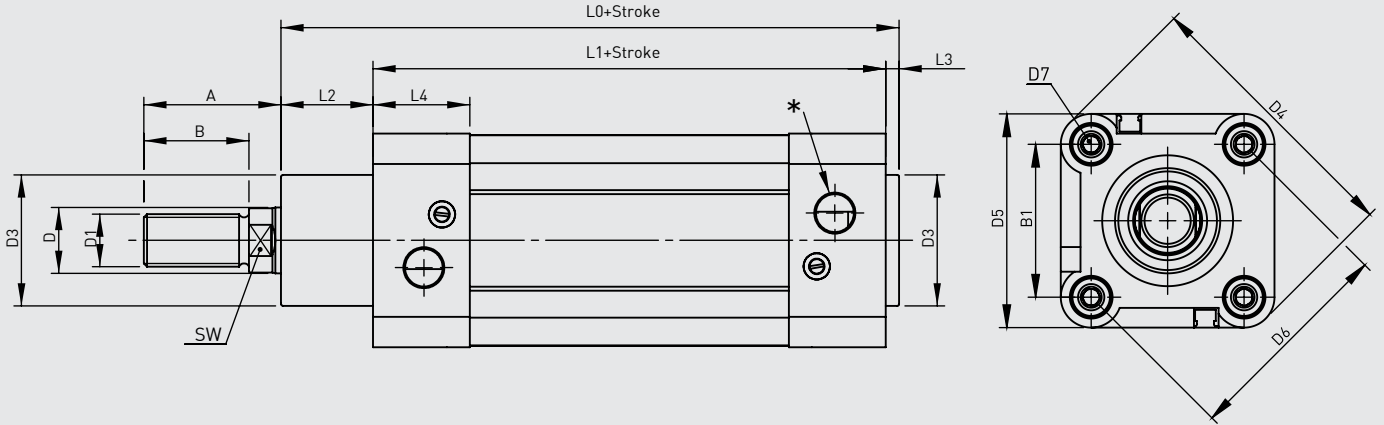

Silindir Ø mm	A	B	B1	D Ø	D1	D3 Ø	D4	D5	D6 Ø	D7	L0	L1	L2	L3	L4	L10	L11	SW	*
32	30	22	32.5	12	M10x1.25	30	59	45	46	M6	116	94	18	4	25	120	146	10	G1/8"
40	34	24	38	16	M12x1.25	35	70.2	54	53.7	M6	129	105	20	4	27	135	165	13	G1/4"
50	41	32	46.5	20	M16x1.5	40	84.2	65	65.7	M8	138	106	28	4	29.5	143	180	17	G1/4"
63	42	32	56.5	20	M16x1.5	45	99.5	76	80	M8	152	121	27	4	34.5	158	195	17	G3/8"
80	52	40	72	25	M20x1.5	45	123.8	94	101.8	M10	167	128	34	4	35	174	220	22	G3/8"
100	52.5	40	89	25	M20x1.5	55	148.8	112	125.9	M10	182.5	138	38.5	4	38	189	240	22	G1/2"

FLM FLANGE MOUNTING

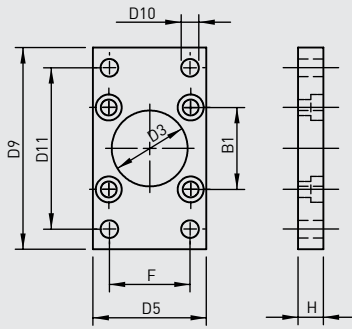

FMF FLANGE MOUNTING AT FRONT

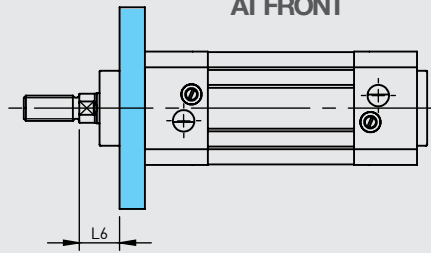

FMTR FLANGE MOUNTING AT REAR

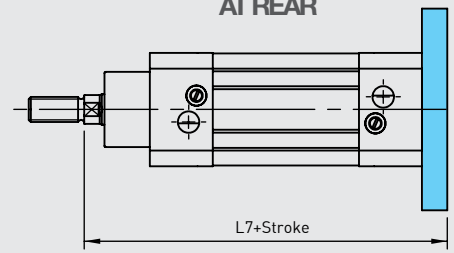

FM FOOT MOUNTING

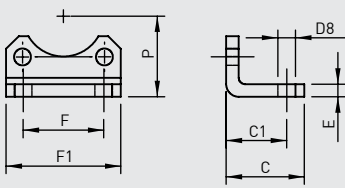

FM FOOT MOUNTING

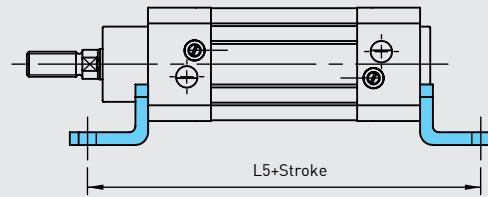

RC ROD CLEVIS

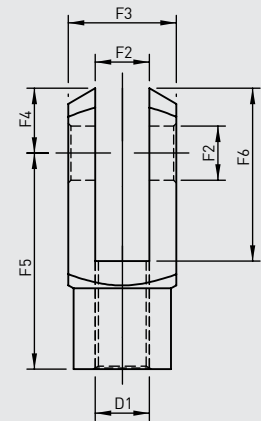

SF SWIVEL FLANGE

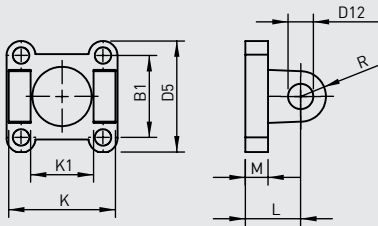

SF SWIVEL FLANGE

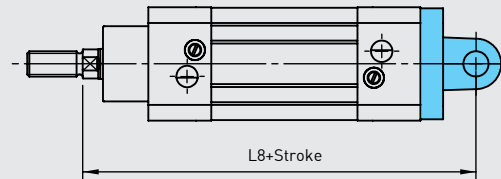

CFM CLEVIS FOOT MOUNTING

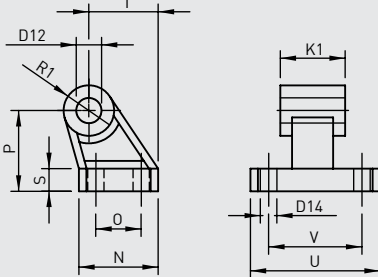

SFWCFM SWIVEL FLANGE WITH CLEVIS FOOT MOUNTING

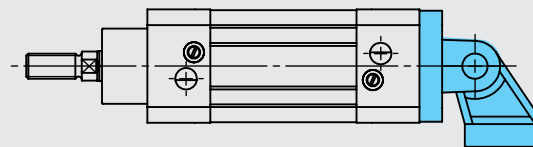

Cylinder Ø mm	B1	C	C1	D1	D3 Ø	D5	D8 Ø	D9	D10 Ø	D11	D12 Ø	D14 Ø	E	F	F1	F2 Ø	F3
32	32.5	30	24	M10x1.25	30	45	7	80	7	64	10	5.5	5	32	45.5	10	20
40	38	37	28	M12x1.25	35	54	10	90	9	72	12	5.5	5	36	54.5	12	24
50	46.5	41	32	M16x1.5	40	65	10	110	9	90	12	6.5	6	45	65	16	32
63	56.5	44	32	M16x1.5	45	76	10	120	9	100	16	6.5	6	50	76	16	32
80	72	56	41	M20x1.5	45	94	12	150	12	126	16	9	6	63	94	20	40
100	89	58	41	M20x1.5	55	112	14	175	14	150	20	9	6	75	112	20	40

Cylinder Ø mm	F4	F5	F6	H	K	K1	L	L5	L6	L7	L8	M	N	O	P	R	R1	S	T	U	V
32	12	40	32	10	45	26	22	142	16	130	142	9	31	18	32	10	10	8	27.5	51	38
40	14	48	38	10	52	28	25	161	20	145	160	9	35	22	36	12	11	10	30.5	54	41
50	19	64	51	12	60	32	27	170	25	155	170	11	45	30	45	13	13	12	40.5	65	50
63	19	64	51	12	70	40	32	185	25	170	190	11	50	35	50	16	15	12	44.5	67	52
80	25	80	65	16	90	50	36	210	30	190	210	14	60	40	63	16	15	14	57	86	66
100	25	80	65	16	110	60	41	220	35	205	230	14	70	50	71	20	19	15	65	96	76

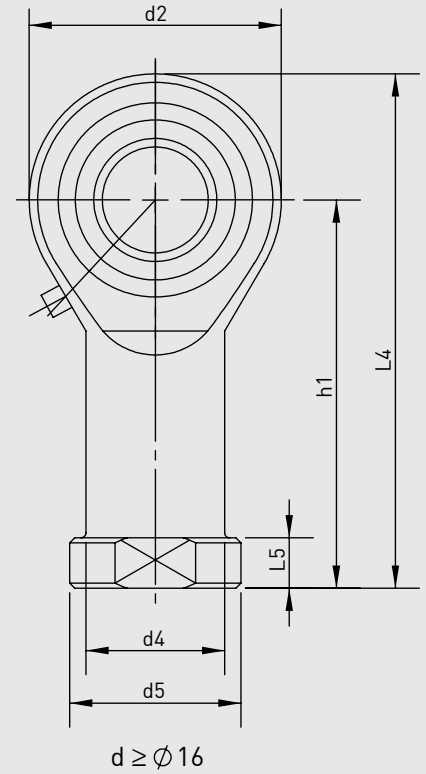
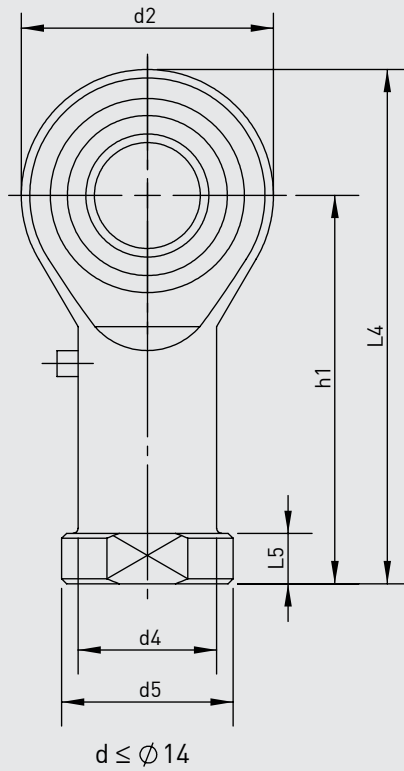
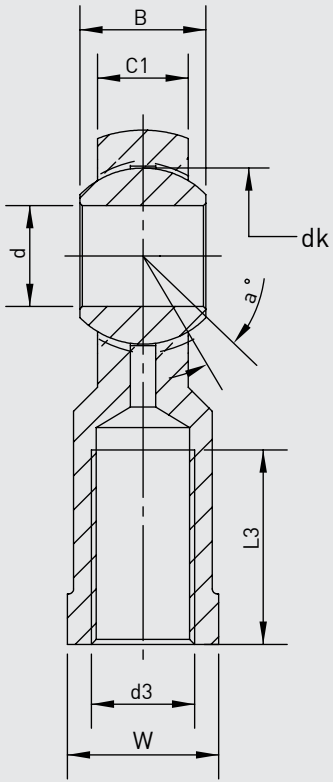

PMT SERIES
ISO 15552 - Ø32 - Ø100

Part No.	Dimensions (mm)													
	d	d3 6H	B	C1	w	L3 min	d2	L4	h1	L5	d4	d5	dk	a°
KMB 10-1	10	M10x1.25	14	10,5	17	20	26	56	43	6,5	15	19	19,05	13
KMB 12-1	12	M12x1.25	16	12	19	22	30	65	50	6,5	17,5	22	22,225	13
KMB 16-1	16	M16x1.5	21	15	22	28	40	84	64	8	22	27	28,575	15
KMB 20	20	M20x1.5	25	18	30	33	50	102	77	10	27,5	34	34,925	14

ISO 1552
PNEUMATIC CYLINDERS
DMC SERIES Ø32 - Ø100





DMC SERIES

ISO 15552 - Ø32 - Ø100

MAGNETIC CUSHIONING CYLINDER

OPTIMUM PRICE,
MAXIMUM PERFORMANCE.

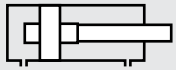

DMC: DOUBLE ACTING CYLINDER WITH CUSHIONING

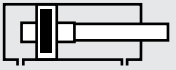

DMC-A: DOUBLE ACTING CYLINDER WITH CUSHIONING AND MAGNETIC

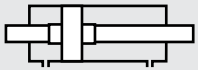

DMC-D: DOUBLE ACTING CYLINDER WITH CUSHIONING AND DOUBLE ROD

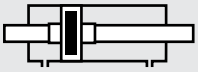

DMC-AD: DOUBLE ACTING CYLINDER WITH CUSHIONING, MAGNETIC AND DOUBLE ROD

Cushioning is standard on these products.

Example of order:

DMC-A
Product Code

050-0100
Cylinder Ø
Stroke

FM
Cylinder
Mountings

M1
Variants from
Standard System

VARIANTS FROM STANDARD SYSTEM:

- R1: Stainless Steel Piston Rod (SS 304-SS 316)
- R3: Stainless Steel Screws for Cylinder Covers (SS 304)
- R4: Stainless Steel Nut for Piston Rod (SS 304)
- R5: Piston Rod as CK45 (Hard chrome plated)
- M1: Extended male Piston Rod Thread
- M2: Female Piston Rod Thread
- M3: Special Piston Rod Thread
- M4: Extended Piston Rod
- K1: Seals for Max. 150°C (Viton)
- K2: Piston Rod Seal NBR + PA
- K3: Seals NBR
- K4: Piston Rod Seal Viton

Working Fluid:

Filtered and lubricated or filtered and not lubricated air

Operating Temperature Range:

Polyurethane (PU) : (-20°C) - (+80°C)
Viton (FKM) : (-30°C) - (+180°C)

Max. Work Pressure:

10 Bar

Force:

Cylinder Ø mm	Rod Ø mm	Thrust and traction forces(6 Bar)	
		Thrust Force (N)	Traction Force (N)
32	12	482	415
40	16	754	633
50	20	1178	990
63	20	1870	1682
80	25	3016	2721
100	25	4712	4418

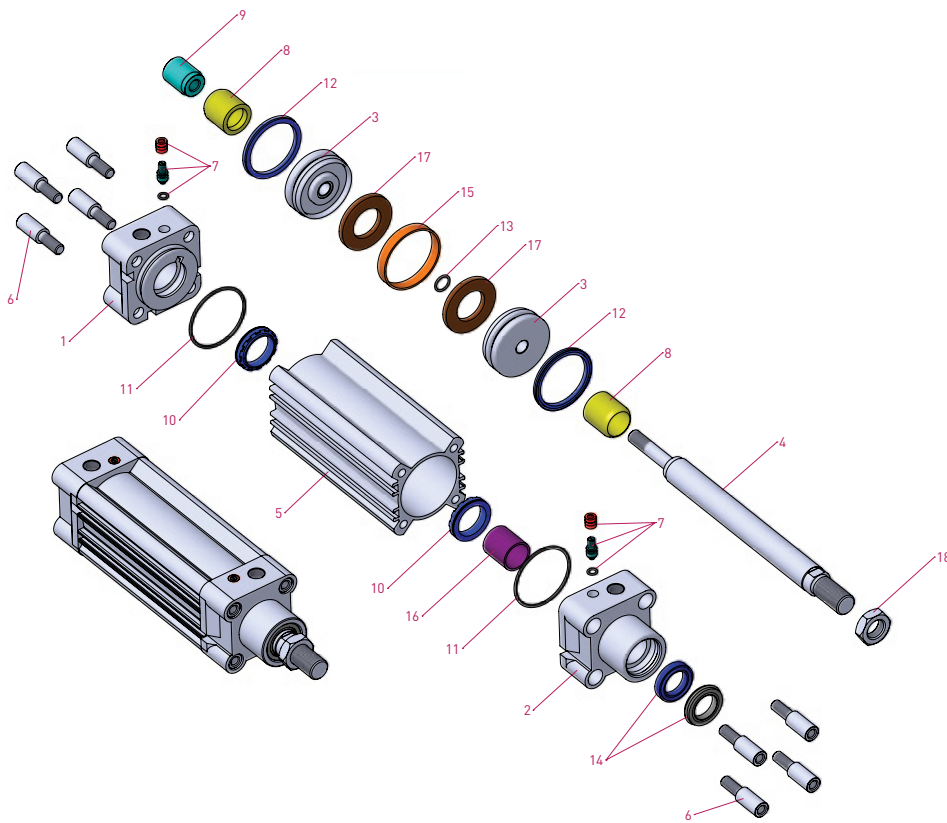
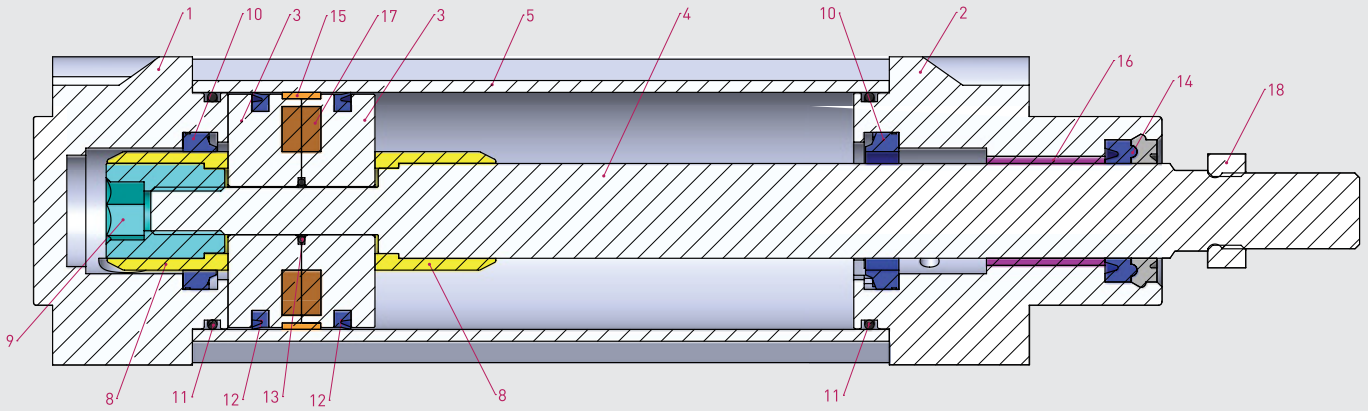

No	MATERIAL NAME	CHARACTERISTIC	PC.
1	Rear Head	Aluminium	1
2	Front Head	Aluminium	1
3	Middle Piston	Aluminium	2
4	Piston Rod	X20 Cr13 Hard Chrome Plated	1
5	Tube	Al Mg Si 0,5 + Eloxal Plated	1
6	Bolt	Galvanized Steel	8
7	Cushioning Screw	6082 AL. + Eloxal + AISI 303 NBR	2
8	Cushioning Plastic	Polyacetal	2
9	Cushioning Fem. Thread	Galvanized Steel	1
10	Cushioning Seal	PU	2
11	Head O-ring	NBR	2

No	MATERIAL NAME	CHARACTERISTIC	PC.
12	Piston Seal	PU	2
13	Middle Piston O-ring	NBR	1
14	Rod Seal	HYTREL + PU	1
15	Guiding Band	Polyacetal	1
16	Guiding Bush	CSB-40	1
17	Magnet		2
18	Nut	Galvanized Steel	1

Note:
Dia 32: Instead of Cushioning Plastic is used Cushioning yellow and instead of Cushioning Plastic Female Thread is used Cushioning yellow Female Thread. (Material:Brass)

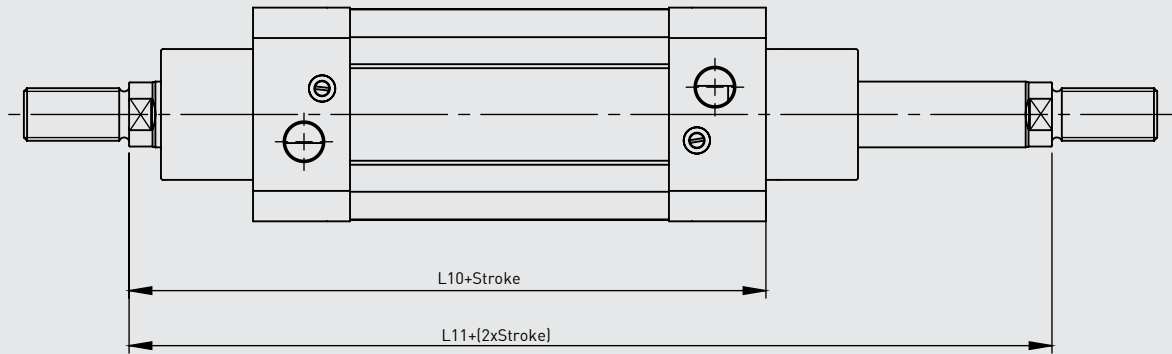
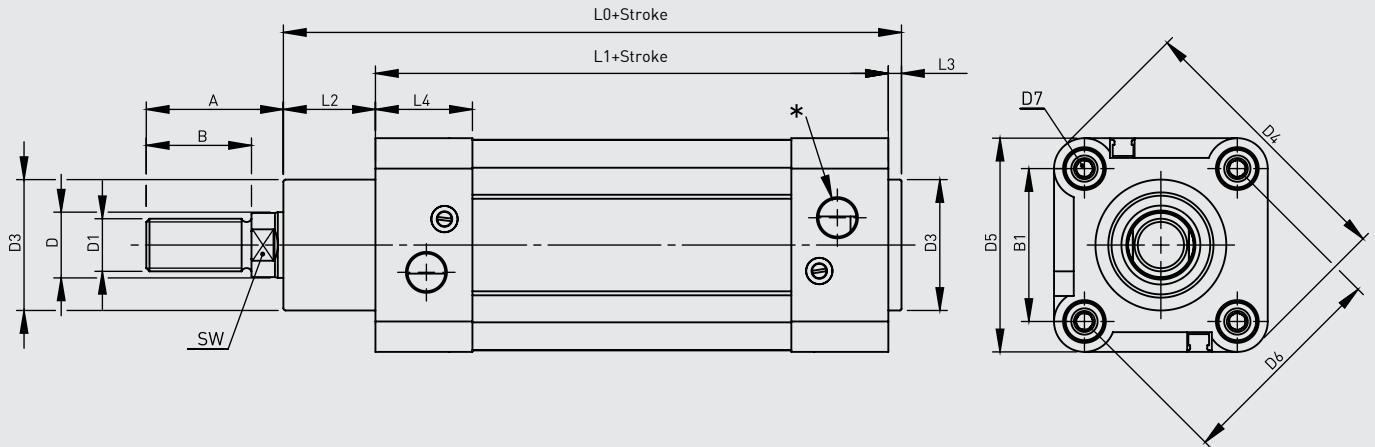

Cylinder Ø mm	A	B	B1	D Ø	D1	D3 Ø	D4	D5	D6 Ø	D7	L0	L1	L2	L3	L4	L10	L11	SW	*
32	30	22	32.5	12	M10x1.25	30	59	45	46	M6	116	94	18	4	25	120	146	10	G1/8"
40	34	24	38	16	M12x1.25	35	70,2	54	53.7	M6	129	105	20	4	27	135	165	13	G1/4"
50	41	32	46.5	20	M16x1.5	40	84,2	65	65.7	M8	138	106	28	4	29.5	143	180	17	G1/4"
63	42	32	56.5	20	M16x1.5	45	99,5	76	80	M8	152	121	27	4	34.5	158	195	17	G3/8"
80	52	40	72	25	M20x1.5	45	123.8	94	101.8	M10	167	128	34	4	35	174	220	22	G3/8"
100	52.5	40	89	25	M20x1.5	55	148.8	112	125.9	M10	182.5	138	38.5	4	38	189	240	22	G1/2"

FLM FLANGE MOUNTING

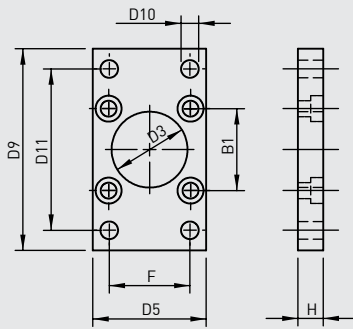

FMF FLANGE MOUNTING AT FRONT

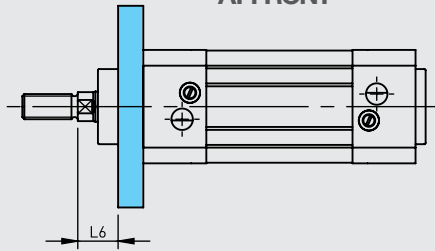

FMTR FLANGE MOUNTING AT REAR

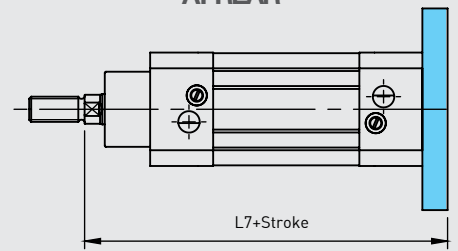

FM FOOT MOUNTING

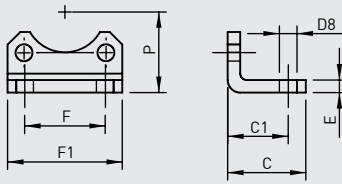

FM FOOT MOUNTING

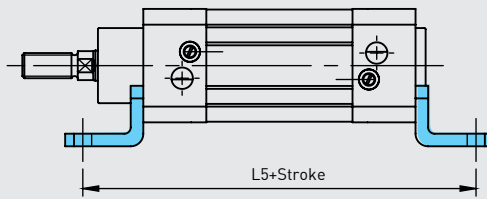

SF SWIVEL FLANGE

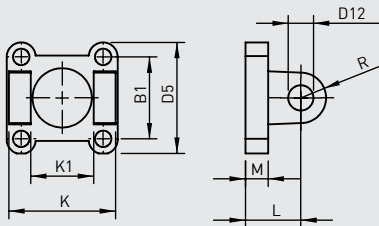

SF SWIVEL FLANGE

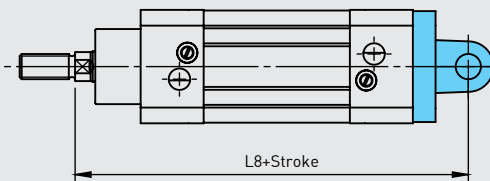

RC ROD CLEVIS

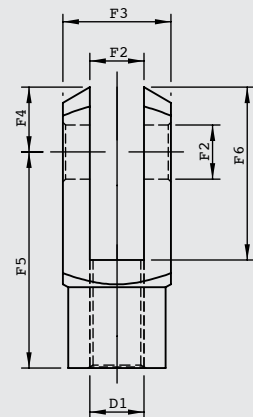

CFM CLEVIS FOOT MOUNTING

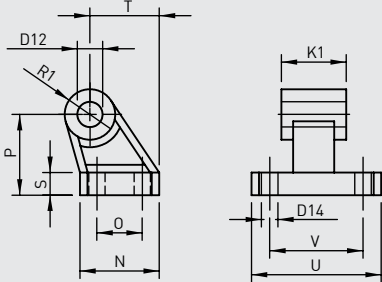

SFWCFM SWIVEL FLANGE WITH CLEVIS FOOT MOUNTING

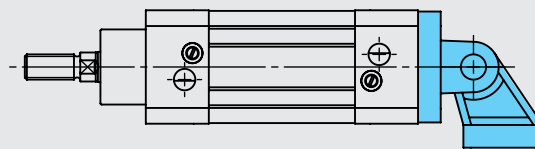

Cylinder Ø mm	B1	C	C1	D1	D3 Ø	D5	D8 Ø	D9	D10 Ø	D11	D12 Ø	D14 Ø	E	F	F1	F2 Ø	F3
32	32.5	30	24	M10x1.25	30	45	7	80	7	64	10	5.5	5	32	45.5	10	20
40	38	37	28	M12x1.25	35	54	10	90	9	72	12	5.5	5	36	54.5	12	24
50	46.5	41	32	M16x1.5	40	65	10	110	9	90	12	6.5	6	45	65	16	32
63	56.5	44	32	M16x1.5	45	76	10	120	9	100	16	6.5	6	50	76	16	32
80	72	56	41	M20x1.5	45	94	12	150	12	126	16	9	6	63	94	20	40
100	89	58	41	M20x1.5	55	112	14	175	14	150	20	9	6	75	112	20	40

Cylinder Ø mm	F4	F5	F6	H	K	K1	L	L5	L6	L7	L8	M	N	O	P	R	R1	S	T	U	V
32	12	40	32	10	45	26	22	142	16	130	142	9	31	18	32	10	10	8	27.5	51	38
40	14	48	38	10	52	28	25	161	20	145	160	9	35	22	36	12	11	10	30.5	54	41
50	19	64	51	12	60	32	27	170	25	155	170	11	45	30	45	13	13	12	40.5	65	50
63	19	64	51	12	70	40	32	185	25	170	190	11	50	35	50	16	15	12	44.5	67	52
80	25	80	65	16	90	50	36	210	30	190	210	14	60	40	63	16	15	14	57	86	66
100	25	80	65	16	110	60	41	220	35	205	230	14	70	50	71	20	19	15	65	96	76

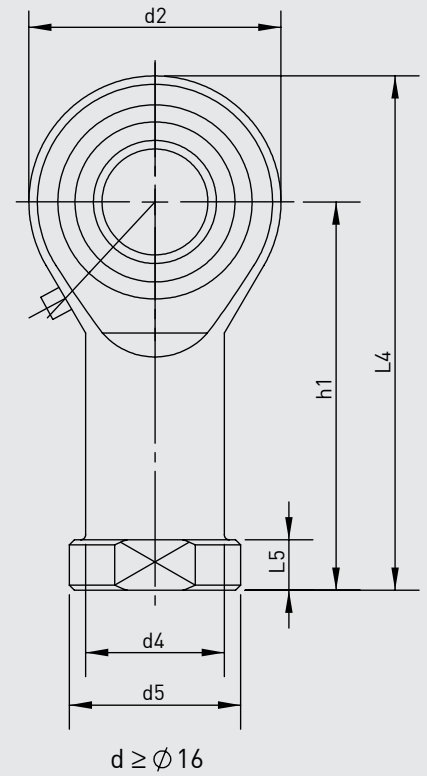
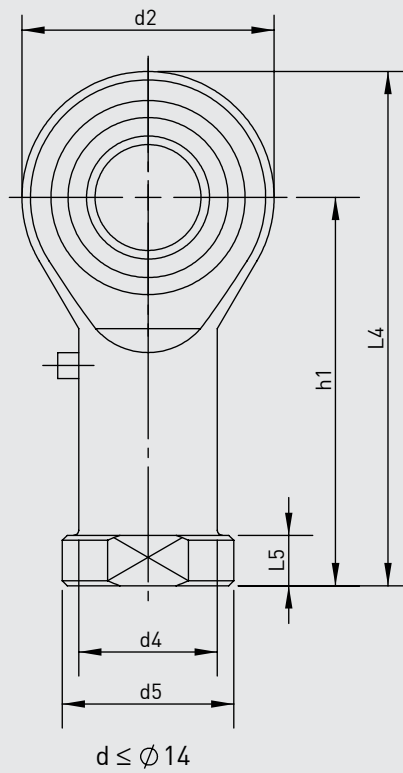
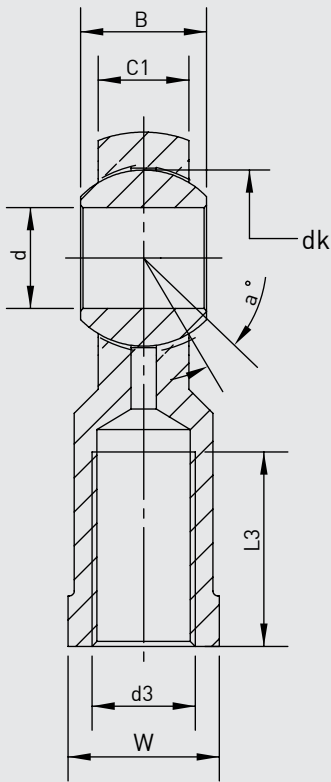

DMC SERIES
ISO 15552 - Ø32 - Ø100

Part No.	Dimensions (mm)													
	d	d3 6H	B	C1	w	L3 min	d2	L4	h1	L5	d4	d5	dk	a°
KMB 10-1	10	M10x1.25	14	10,5	17	20	26	56	43	6,5	15	19	19,05	13
KMB 12-1	12	M12x1.25	16	12	19	22	30	65	50	6,5	17,5	22	22,225	13
KMB 16-1	16	M16x1.5	21	15	22	28	40	84	64	8	22	27	28,575	15
KMB 20	20	M20x1.5	25	18	30	33	50	102	77	10	27,5	34	34,925	14

ISO 1552
PNEUMATIC CYLINDERS
PNY SERIES Ø32 - Ø100





PNY SERIES
ISO 15552 - Ø32 - Ø100

CUSHIONING CYLINDER

OPTIMUM PRICE,
MAXIMUM PERFORMANCE.

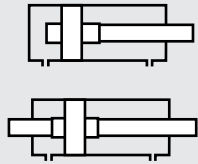

PNY: DOUBLE ACTING CYLINDER WITH CUSHIONING

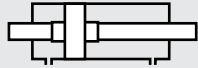

PNY-D: DOUBLE ACTING CYLINDER WITH CUSHIONING AND DOUBLE ROD

Cushioning is standard on these products.

Example of order:

<u>PNY</u>	<u>050-0100</u>	<u>FLM</u>	<u>M1 M3</u>
Product Code	Cylinder Ø Stroke	Cylinder Mountings	Variants from Standard System

VARIANTS FROM STANDARD SYSTEM:

- R1: Stainless Steel Piston Rod (SS 304-SS 316)
- R3: Stainless Steel Screws for Cylinder Covers (SS 304)
- R4: Stainless Steel Nut for Piston Rod (SS 304)
- M1: Extended male Piston Rod Thread
- M2: Female Piston Rod Thread
- M3: Special Piston Rod Thread
- M4: Extended Piston Rod
- K1: Seals for Max. 150°C (Viton)
- K2: Piston Rod Seal NBR + PA
- K3: Seals NBR
- K4: Piston Rod Seal Viton

Force:

Cylinder Ø mm	Rod Ø mm	Thrust and traction forces(6 Bar)	
		Thrust Force (N)	Traction Force (N)
32	12	482	415
40	16	754	633
50	20	1178	990
63	20	1870	1682
80	25	3016	2721
100	25	4712	4418

Working Fluid:

Filtered and lubricated or filtered and not lubricated air

Operating Temperature Range:

Polyurethane (PU) : (-20°C) - (+80°C)
Viton (FKM) : (-30°C) - (+180°C)

Max. Work Pressure:

10 Bar

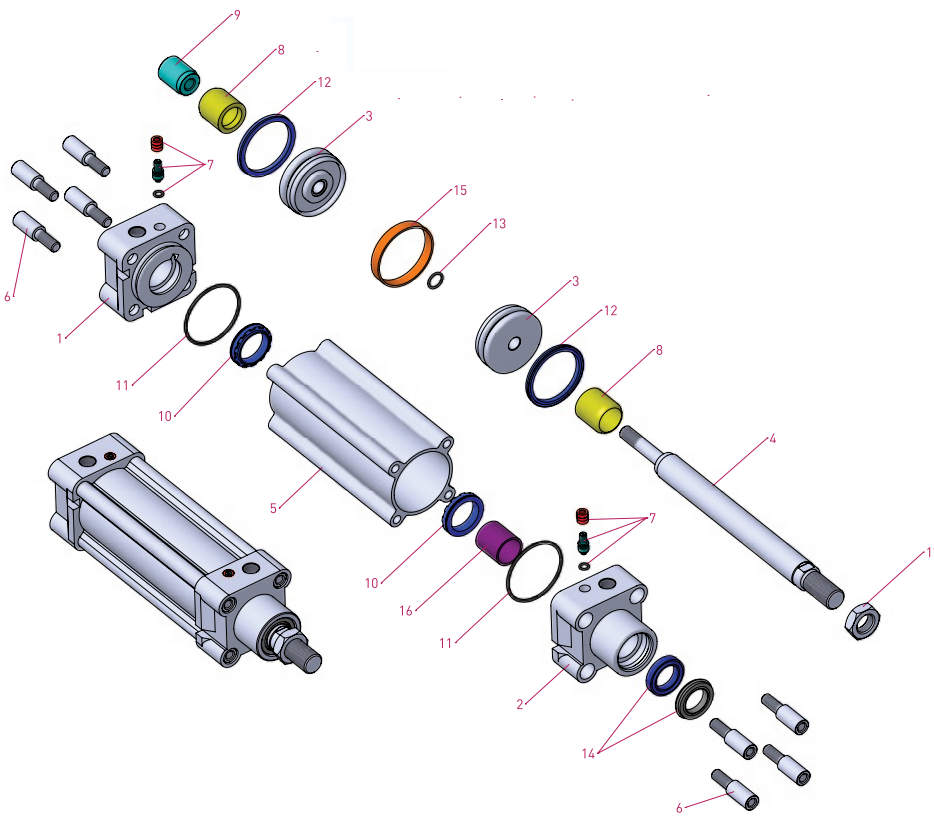
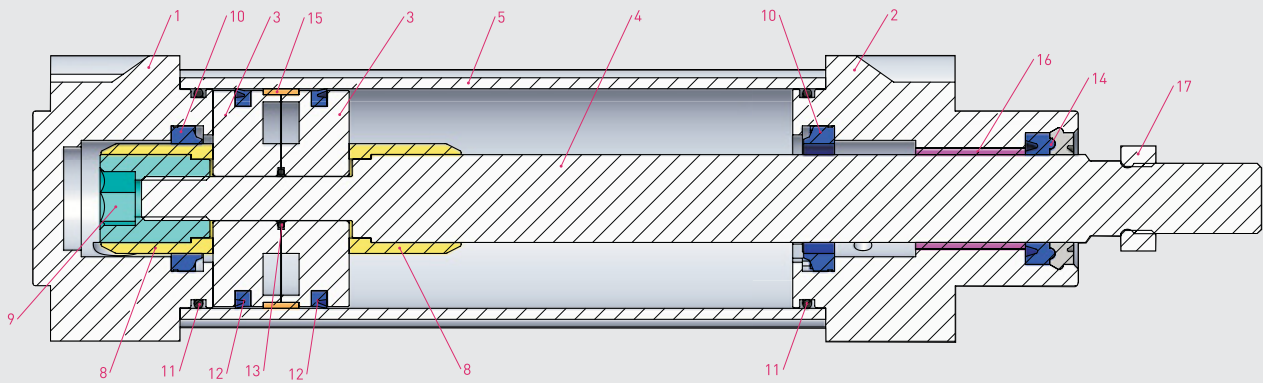

No	MATERIAL NAME	CHARACTERISTIC	PC.
1	Rear Head	Aluminium	1
2	Front Head	Aluminium	1
3	Middle Piston	Aluminium	2
4	Piston Rod	CK 45 Hard Chrome Plated	1
5	Tube	Al Mg Si 0,5 + Eloxal Plated	1
6	Bolt	Galvanized Steel	8
7	Cushioning Screw	6082 AL. + Eloxal + AISI 303 NBR	2
8	Cushioning Plastic	Polyacetal	2
9	Cushioning Fem. Thread	Galvanized Steel	1
10	Cushioning Seal	PU	2
11	Head O-ring	NBR	2

No	MATERIAL NAME	CHARACTERISTIC	PC.
12	Piston Seal	PU	2
13	Middle Piston O-ring	NBR	1
14	Rod Seal	HYTREL + PU	1
15	Guiding Band	Polyacetal	1
16	Guiding Bush	CSB-40	1
17	Nut	Galvanized Steel	1

Note:

Dia 32: Instead of Cushioning Plastic is used Cushioning yellow and instead of Cushioning Plastic Female Thread is used Cushioning yellow Female Thread. (Material: Brass)

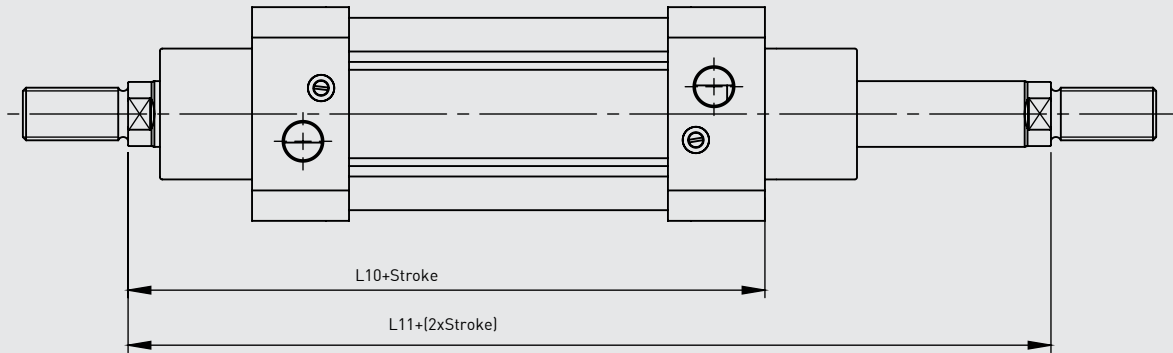
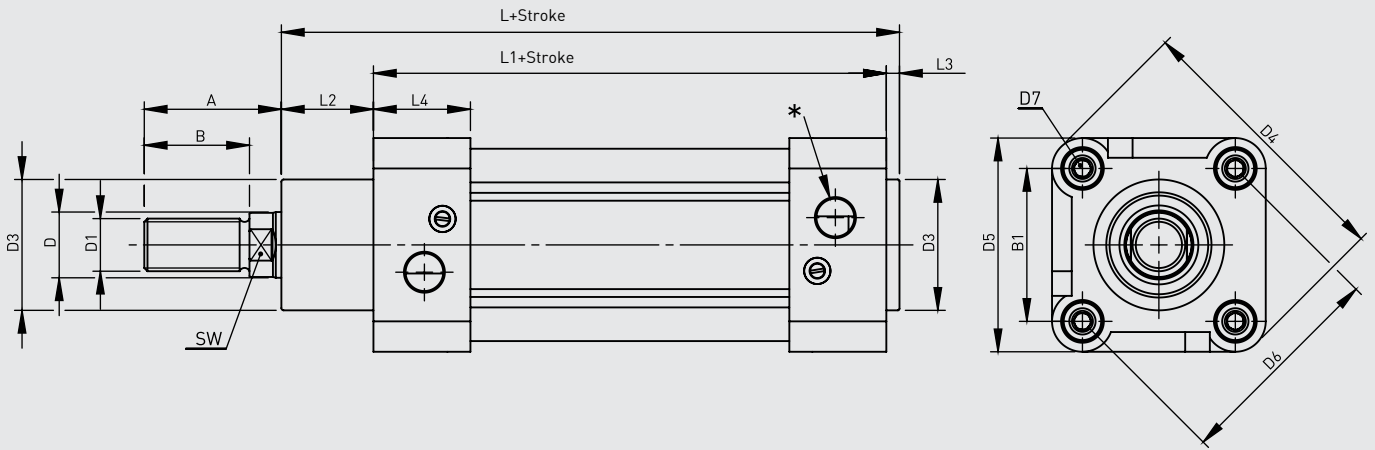

Cylinder Ø mm	A	B	B1	D Ø	D1	D3 Ø	D4	D5	D6 Ø	D7	L0	L1	L2	L3	L4	L10	L11	SW	*
32	30	22	32,5	12	M10x1.25	30	59	45	46	M6	116	94	18	4	25	120	146	10	G1/8''
40	34	24	38	16	M12x1.25	35	70,2	54	53,7	M6	129	105	20	4	27	135	165	13	G1/4''
50	41	32	46,5	20	M16x1.5	40	84,2	65	65,7	M8	138	106	28	4	29,5	143	180	17	G1/4''
63	42	32	56,5	20	M16x1.5	45	99,5	76	80	M8	152	121	27	4	34,5	158	195	17	G3/8''
80	52	40	72	25	M20x1.5	45	123,8	94	101,8	M10	167	128	34	4	35	174	220	22	G3/8''
100	52,5	40	89	25	M20x1.5	55	148,8	112	125,9	M10	182,5	138	38,5	4	38	189	240	22	G1/2''

FLM FLANGE MOUNTING

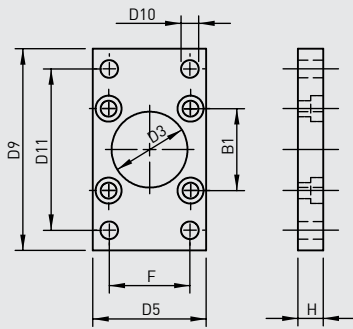

**FMF FLANGE MOUNTING
AT FRONT**

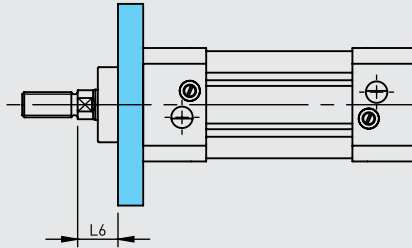

**FMTR FLANGE MOUNTING
AT REAR**

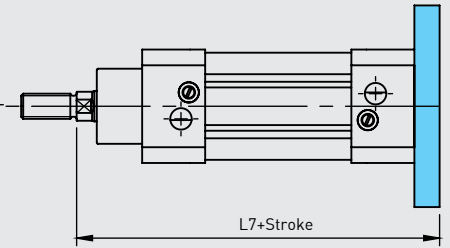

FM FOOT MOUNTING

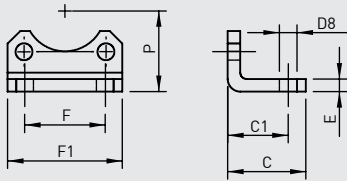

FM FOOT MOUNTING

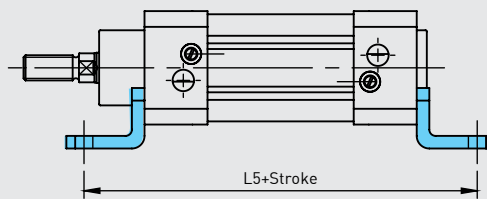

SF SWIVEL FLANGE

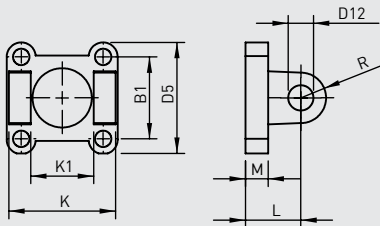

SF SWIVEL FLANGE

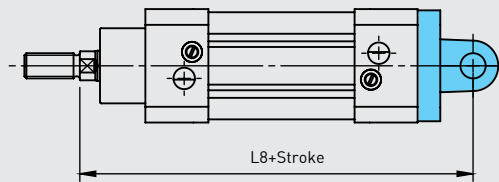

RC ROD CLEVIS

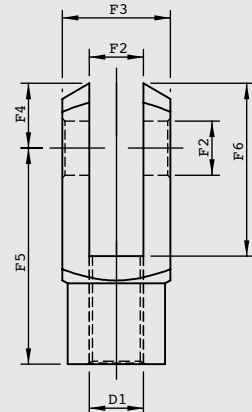

CFM CLEVIS FOOT MOUNTING

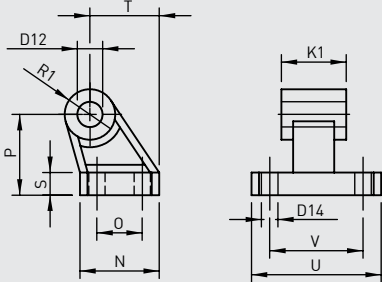

**SFWCFM SWIVEL FLANGE WITH CLEVIS
FOOT MOUNTING**

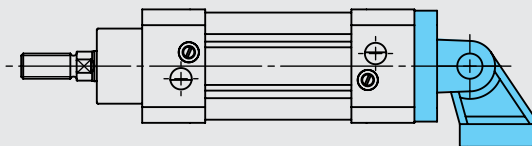

Cylinder Ø mm	B1	C	C1	D1	D3 Ø	D5	D8 Ø	D9	D10 Ø	D11	D12 Ø	D14 Ø	E	F	F1	F2 Ø	F3
32	32,5	30	24	M10x1.25	30	45	7	80	7	64	10	5,5	5	32	45,5	10	20
40	38	37	28	M12x1.25	35	54	10	90	9	72	12	5,5	5	36	54,5	12	24
50	46,5	41	32	M16x1.5	40	65	10	110	9	90	12	6,5	6	45	65	16	32
63	56,5	44	32	M16x1.5	45	76	10	120	9	100	16	6,5	6	50	76	16	32
80	72	56	41	M20x1.5	45	94	12	150	12	126	16	9	6	63	94	20	40
100	89	58	41	M20x1.5	55	112	14	175	14	150	20	9	6	75	112	20	40

Cylinder Ø mm	F3	F5	F6	H	K	K1	L	L5	L6	L7	L8	M	N	O	P	R	R1	S	T	U	V
32	12	40	32	10	45	26	22	142	16	130	142	9	31	18	32	10	10	8	27,5	51	38
40	14	48	38	10	52	28	25	161	20	145	160	9	35	22	36	12	11	10	30,5	54	41
50	19	64	51	12	60	32	27	170	25	155	170	11	45	30	45	13	13	12	40,5	65	50
63	19	64	51	12	70	40	32	185	25	170	190	11	50	35	50	16	15	12	44,5	67	52
80	25	80	65	16	90	50	36	210	30	190	210	14	60	40	63	16	15	14	57	86	66
100	25	80	65	16	110	60	41	220	35	205	230	14	70	50	71	20	19	15	65	96	76

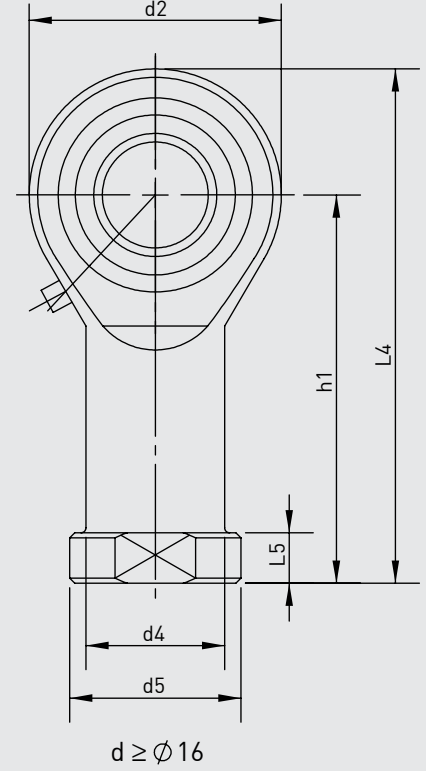
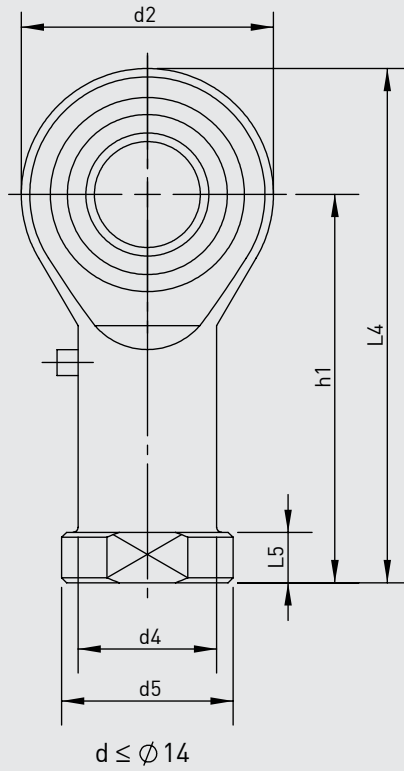
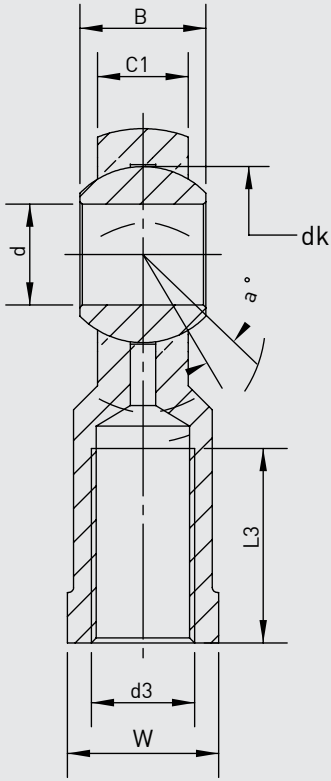

PNY SERIES
ISO 15552 - Ø32 - Ø100

Part No.	Dimensions (mm)													
	d	d3 6H	B	C1	w	L3 min	d2	L4	h1	L5	d4	d5	dk	a°
KMB 10-1	10	M10x1.25	14	10,5	17	20	26	56	43	6,5	15	19	19,05	13
KMB 12-1	12	M12x1.25	16	12	19	22	30	65	50	6,5	17,5	22	22,225	13
KMB 16-1	16	M16x1.5	21	15	22	28	40	84	64	8	22	27	28,575	15
KMB 20	20	M20x1.5	25	18	30	33	50	102	77	10	27,5	34	34,925	14

ISO 15552
PNEUMATIC CYLINDERS
PNC SERIES Ø32 - Ø125





PNC SERIES

ISO 15552 - Ø32 - Ø125

CUSHIONING CYLINDER

LONG-LASTING AND
ALSO INEXPENSIVE

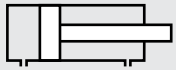

PNC: DOUBLE ACTING CYLINDER

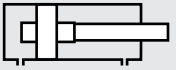

PNC-Y: DOUBLE ACTING CYLINDER
WITH CUSHIONING

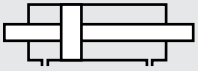

PNC-D: DOUBLE ACTING CYLINDER
WITH DOUBLE ROD

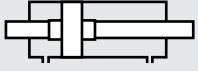

PNC-YD: DOUBLE ACTING CYLINDER
WITH CUSHIONING AND DOUBLE ROD

Example of order:

PNC-Y
Product Code

050-0100
Cylinder Ø
Stroke

FLM
Cylinder
Mountings

K4
Variants from
Standard System

VARIANTS FROM STANDARD SYSTEM:

- R1: Stainless Steel Piston Rod (SS 304-SS 316)
- R3: Stainless Steel Screws for Cylinder Covers (SS 304)
- R4: Stainless Steel Nut for Piston Rod (SS 304)
- M1: Extended male Piston Rod Thread
- M2: Female Piston Rod Thread
- M3: Special Piston Rod Thread
- M4: Extended Piston Rod
- E1: Hard Eloxal Plated, Anticorrosive Aluminium Covers
- K1: Seals for Max. 150°C (Viton)
- K2: Piston Rod Seal NBR + PA
- K3: Seals NBR
- K4: Piston Rod Seal Viton

Working Fluid:

Filtered and lubricated air

Operating Temperature Range:

NBR+Polyurethane (PU): (-20°C) - (+80°C)
Viton (FKM) : (-30°C) - (+180°C)

Max. Work Pressure:

10 Bar

Force:

Cylinder Ø mm	Rod Ø mm	Thrust and traction forces(6 Bar)	
		Thrust Force (N)	Traction Force (N)
32	12	482	415
40	16	754	633
50	20	1178	990
63	20	1870	1682
80	25	3016	2721
100	25	4712	4418
125	32	7363	6881

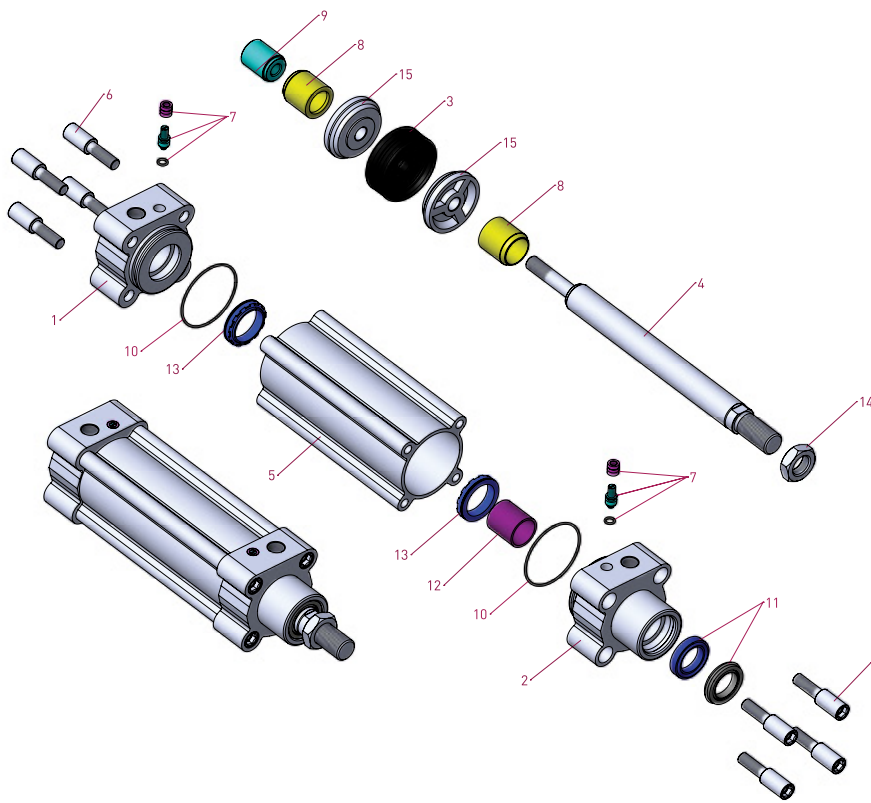
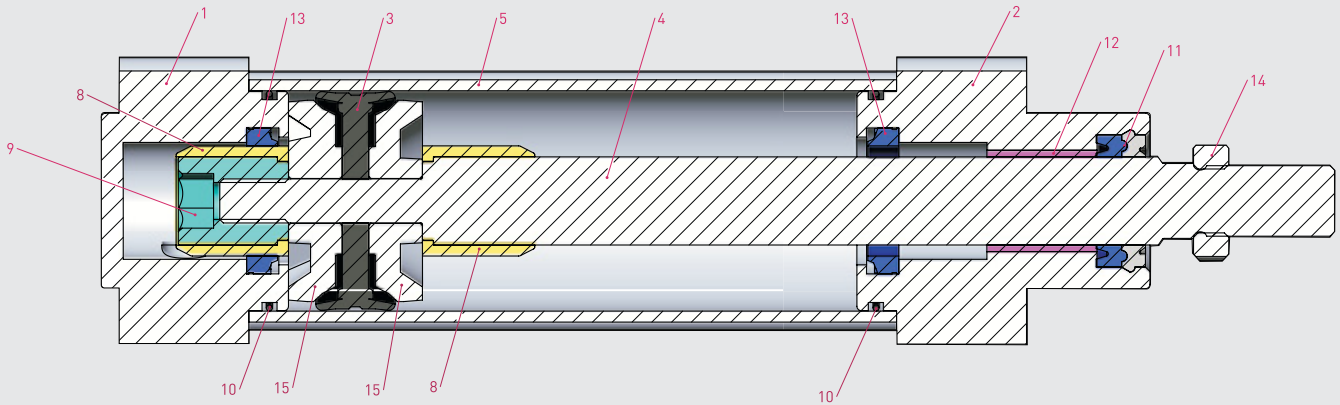

No	MATERIAL NAME	CHARACTERISTIC	PC.
1	Rear Head	Aluminium	1
2	Front Head	Aluminium	1
3	Piston Seal	NBR	1
4	Piston Rod	CK 45 Hard Chrome Plated	1
5	Tube	Al Mg Si 0,5 + Eloxal Plated	1
6	Bolt	Galvanized Steel	8
7	Cushioning Screw	6082 AL.+Eloxal+AISI 303 NBR	2
8	Cushioning Plastic	Polycetal	2
9	Cushioning Fem. Thread	Galvanized-Plated Steel	1
10	Head O-ring	NBR	2

No	MATERIAL NAME	CHARACTERISTIC	PC.
11	Rod Seal	HYTREL + PU	1
12	Guiding Bush	CSB-40	1
13	Cushioning Seal	PU	2
14	Nut	Galvanized Steel	1
15	Piston Seal Washer	Aluminium	2

Note:

Dia 32: Instead of Cushioning Plastic is used Cushioning yellow and instead of Cushioning Plastic Female Thread is used Cushioning yellow Female Thread. [Material:Brass]

Dia 125: Instead of Cushioning Plastic is used Cushioning Aluminium and instead of Cushioning Plastic Female Thread is used Cushioning Aluminium Female Thread. [Material: Anodized Aluminium]

The Piston Seal Washers exist only as Ø32, Ø40, Ø50

The Parts [Nr. 7, 8, 9, 13] don't exist in the Models Without Cushioning. Fibre Nut and Washer exist instead of the Part Nr. 9

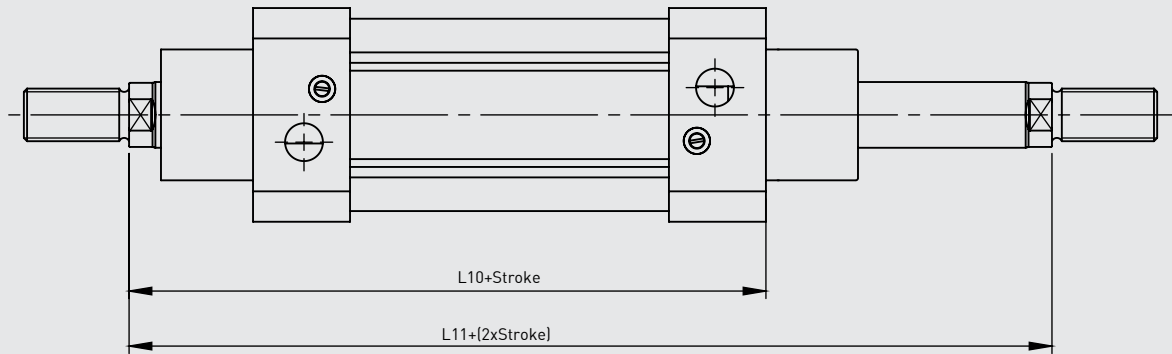
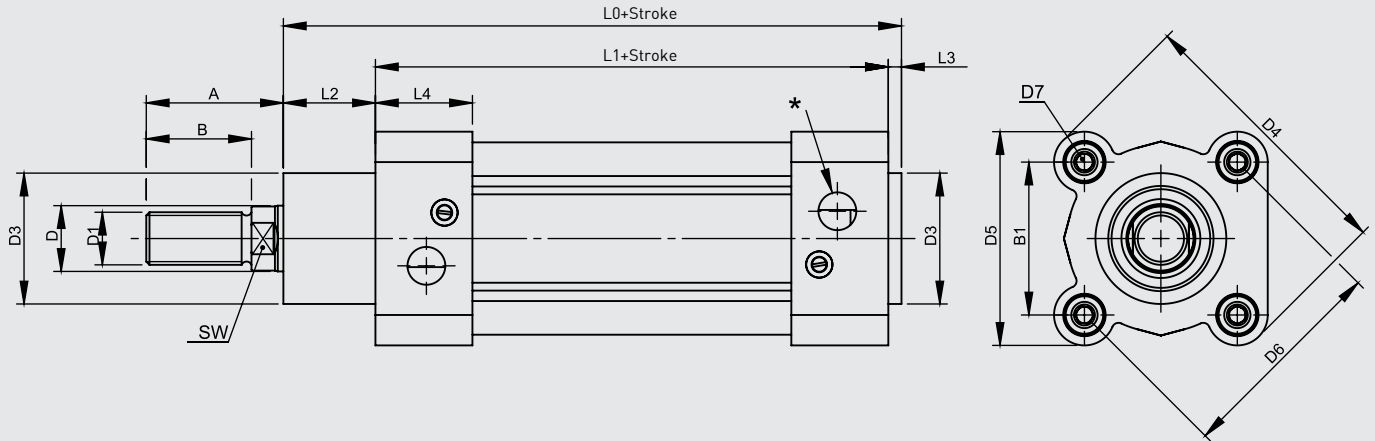

Cylinder Ø mm	A	B	B1	D Ø	D1	D3 Ø	D4	D5	D6 Ø	D7	L0	L1	L2	L3	L4	L10	L11	SW	*
32	30	22	32,5	12	M10x1.25	30	58,5	45	46	M6	116	94	18	4	25	120	146	10	G1/8"
40	34	24	38	16	M12x1.25	35	69,7	54	53,7	M6	129	105	20	4	27	135	165	13	G1/4"
50	41	32	46,5	20	M16x1.5	40	84,2	65	65,7	M8	138	106	28	4	29,5	143	180	17	G1/4"
63	42	32	56,5	20	M16x1.5	45	99,5	76	80	M8	152	121	27	4	34,5	158	195	17	G3/8"
80	52	40	72	25	M20x1.5	45	123,8	94	101,8	M10	167	128	34	4	35	174	220	22	G3/8"
100	52,5	40	89	25	M20x1.5	55	148,8	112	125,9	M10	182,5	138	38,5	4	38	189	240	22	G1/2"
125	73	54	110	32	M27x2	60	180,5	135	155,5	M12	213	160	46	6	44	225	290	27	G1/2"

FLM FLANGE MOUNTING

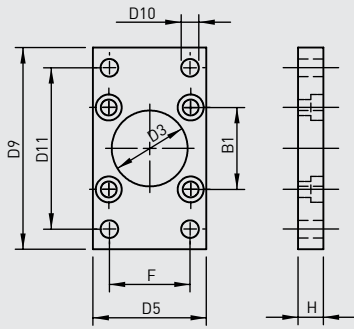

FMF FLANGE MOUNTING AT FRONT

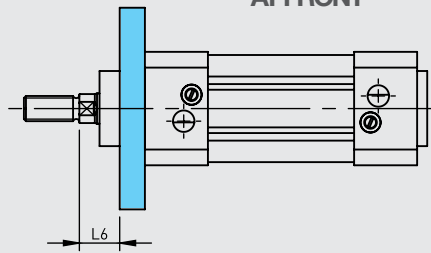

FMTR FLANGE MOUNTING AT REAR

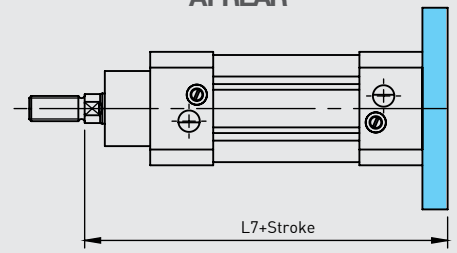

FM FOOT MOUNTING

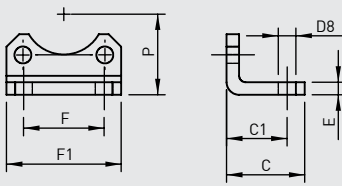

FM FOOT MOUNTING

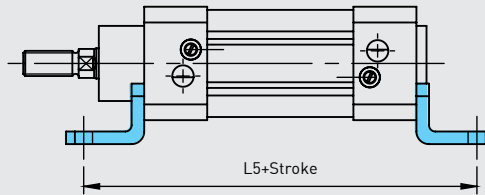

RC ROD CLEVIS

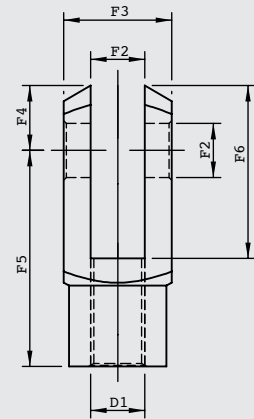

SF SWIVEL FLANGE

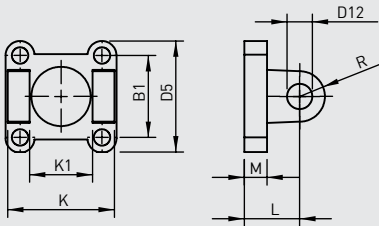

SF SWIVEL FLANGE

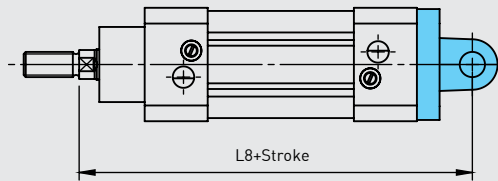

SFWCFM SWIVEL FLANGE WITH CLEVIS FOOT MOUNTING

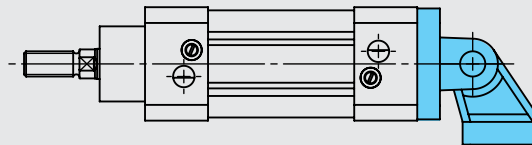

CFM CLEVIS FOOT MOUNTING

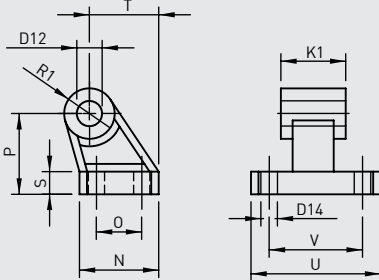

Cylinder Ø mm	B1	C	C1	D1	D3 Ø	D5	D8 Ø	D9	D10 Ø	D11	D12 Ø	D14 Ø	E	F	F1	F2 Ø	F3
32	32.5	30	24	M10x1.25	30	45	7	80	7	64	10	5.5	5	32	45.5	10	20
40	38	37	28	M12x1.25	35	54	10	90	9	72	12	5.5	5	36	54.5	12	24
50	46.5	41	32	M16x1.5	40	65	10	110	9	90	12	6.5	6	45	65	16	32
63	56.5	44	32	M16x1.5	45	76	10	120	9	100	16	6.5	6	50	76	16	32
80	72	56	41	M20x1.5	45	94	12	150	12	126	16	9	6	63	94	20	40
100	89	58	41	M20x1.5	55	112	14	175	14	150	20	9	6	75	112	20	40
125	110	67	45	M27x2	60	134	16	210	16	180	25	11	8	90	131	25	50

Cylinder Ø mm	F4	F5	F6	H	K	K1	L	L5	L6	L7	L8	M	N	O	P	R	R1	S	T	U	V
32	12	40	32	10	45	26	22	142	16	130	142	9	31	18	32	10	10	8	27.5	51	38
40	14	48	38	10	52	28	25	161	20	145	160	9	35	22	36	12	11	10	30.5	54	41
50	19	64	51	12	60	32	27	170	25	155	170	11	45	30	45	13	13	12	40.5	65	50
63	19	64	51	12	70	40	32	185	25	170	190	11	50	35	50	16	15	12	44.5	67	52
80	25	80	65	16	90	50	36	210	30	190	210	14	60	40	63	16	15	14	57	86	66
100	25	80	65	16	110	60	41	220	35	205	230	14	70	50	71	20	19	15	65	96	76
125	32	100	82	20	130	70	50	250	45	245	275	15	90	60	90	25	22.5	20	85	124	94

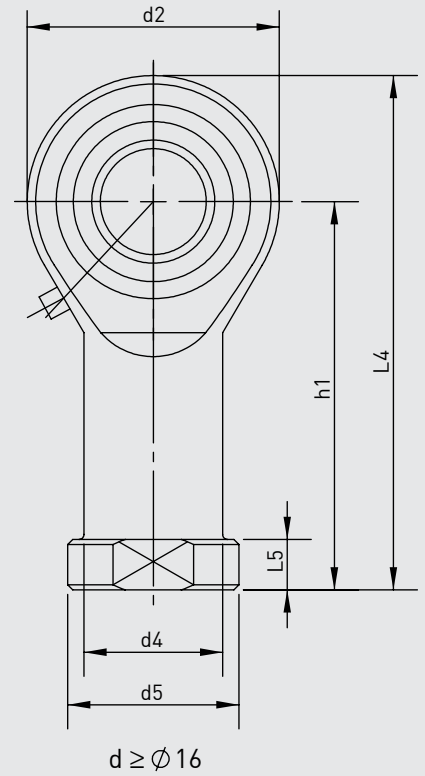
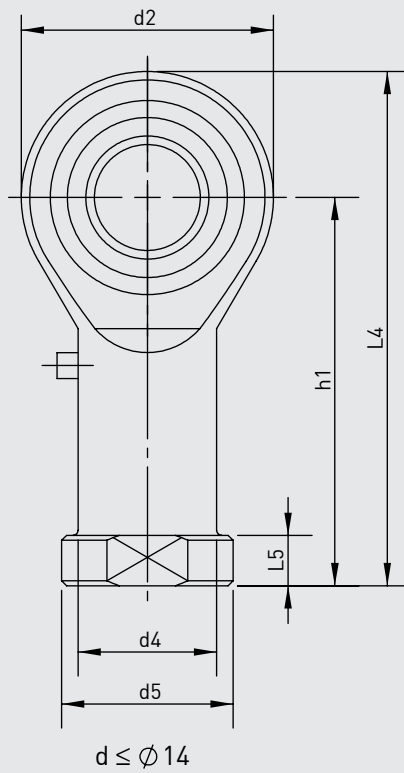
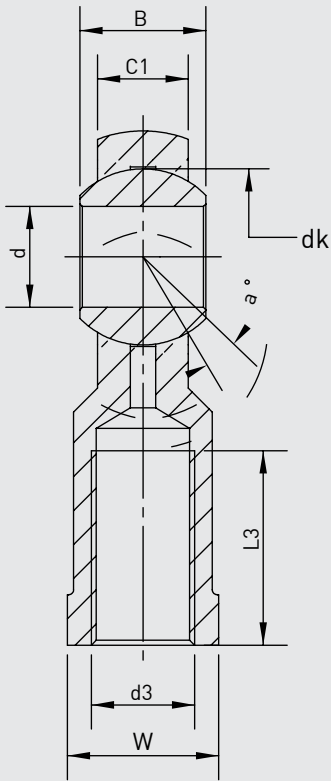

PNC SERIES
ISO 15552 - Ø32 - Ø125

Part No.	Dimensions (mm)													
	d	d3 6H	B	C1	w	L3 min	d2	L4	h1	L5	d4	d5	dk	a°
KMB 10-1	10	M10x1.25	14	10,5	17	20	26	56	43	6,5	15	19	19,05	13
KMB 12-1	12	M12x1.25	16	12	19	22	30	65	50	6,5	17,5	22	22,225	13
KMB 16-1	16	M16x1.5	21	15	22	28	40	84	64	8	22	27	28,575	15
KMB 20	20	M20x1.5	25	18	30	33	50	102	77	10	27,5	34	34,925	14
KMB 28	28	M27x2.0	35	24	41	48	66	136	103	14	37	46	47.6	15
KMB 30	30	M30x2.0	37	25	41	51	70	145	110	15	40	50	50,8	17

ISO 15552
PNEUMATIC CYLINDERS
ISP-M SERIES Ø32 - Ø125





ISP-M SERIES

ISO 15552 - Ø32 - Ø125

MAGNETIC CUSHIONING CYLINDER

ELOXAL PLATE AND SPECIAL ROD SEAL PROVIDING HYGIENE AND LONG WORKING LIFE



Example of order:

<u>ISP-M</u>	<u>050-0100</u>	<u>FLM</u>	<u>K1</u>
Product Code	Cylinder Ø Stroke	Cylinder Mountings	Variants from Standard System

VARIANTS FROM STANDARD SYSTEM:

- R1: Stainless Steel Piston Rod (SS 304-SS 316)
- R5: Piston Rod as CK45 (Hard chrome plated)
- M1: Extended male Piston Rod Thread
- M2: Female Piston Rod Thread
- M3: Special Piston Rod Thread
- M4: Extended Piston Rod
- K1: Seals for Max. 150°C (Viton)
- K2: Piston Rod Seal NBR + PA
- K3: Seals NBR
- K4: Piston Rod Seal Viton

Working Fluid:

Filtered and lubricated or filtered and not lubricated air

Operating Temperature Range:

Polyurethane (PU) : (-20°C) - (+80°C)
 Viton (FKM) : (-30°C) - (+180°C)

Max. Work Pressure:

10 Bar

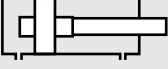
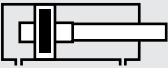
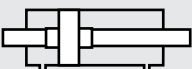
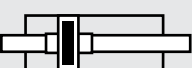
-  **ISP** DOUBLE ACTING CYLINDER WITH CUSHIONING
-  **ISP-M:** DOUBLE ACTING CYLINDER WITH CUSHIONING AND MAGNETIC
-  **ISP-D:** DOUBLE ACTING CYLINDER WITH CUSHIONING AND DOUBLE ROD
-  **ISP-MD:** DOUBLE ACTING CYLINDER WITH CUSHIONING, MAGNETIC AND DOUBLE ROD

Cushioning is standard on these products.

Force:

Cylinder Ø mm	Rod Ø mm	Thrust and traction forces(6 Bar)	
		Thrust Force (N)	Traction Force (N)
32	12	482	415
40	16	754	633
50	20	1178	990
63	20	1870	1682
80	25	3016	2721
100	25	4712	4418
125	32	7363	6881

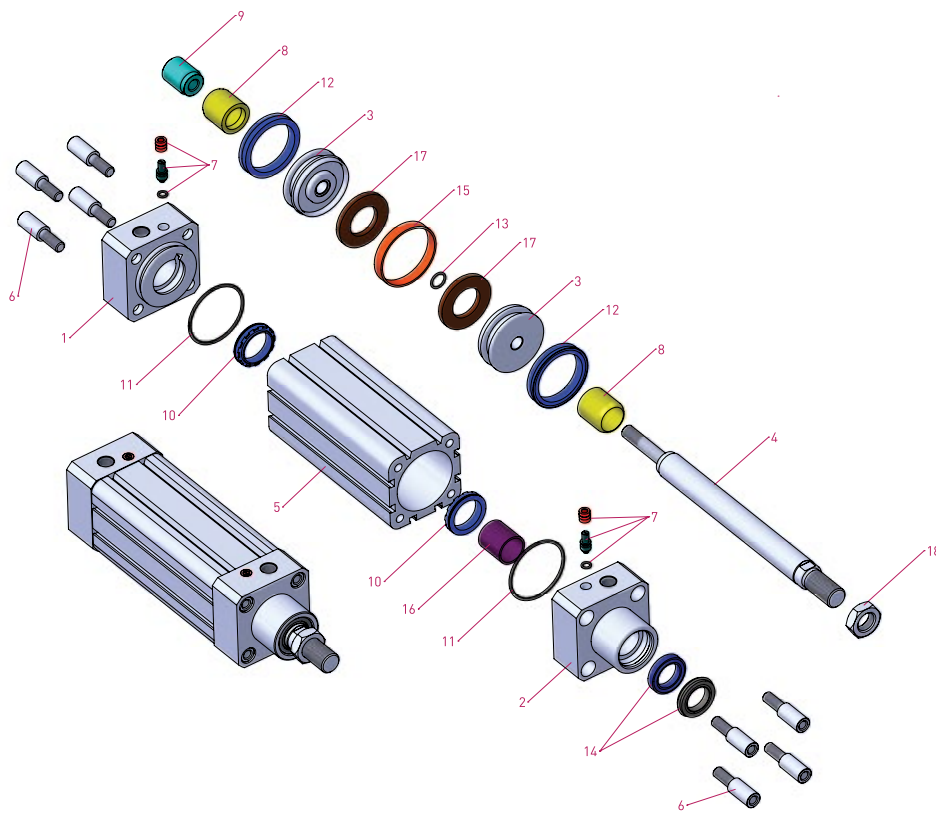
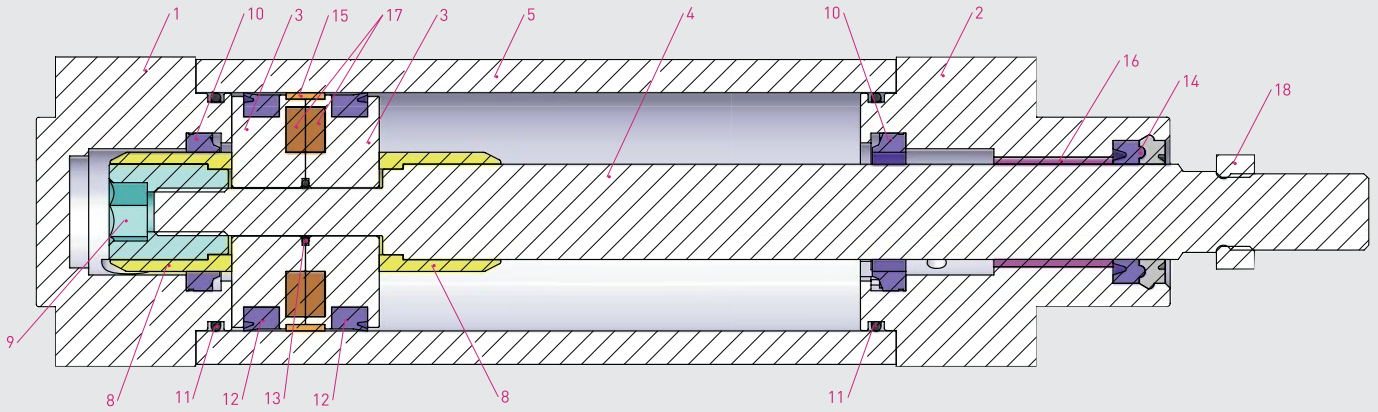

No	MATERIAL NAME	CHARACTERISTIC	PC.
1	Rear Head	6082 Al.+ Eloxac Plated	1
2	Front Head	6082 Al.+ Eloxac Plated	1
3	Middle Piston	Aluminium	2
4	Piston Rod	X20 Cr13 Hard Chrome Plated	1
5	Tube	Al Mg Si 0,5 + Eloxac Plated	1
6	Bolt	Stainless Steel	8
7	Cushioning Screw	6082 Al. + Eloxac + AISI 303 NBR	2
8	Cushioning Plastic	Polyacetal	2
9	Cushioning Fem. Thread	Galvanized Steel	1
10	Cushioning Seal	PU	2
11	Head O-ring	NBR	2

No	MATERIAL NAME	CHARACTERISTIC	PC.
12	Piston Seal	PU	2
13	Middle Piston O-ring	NBR	1
14	Rod Seal	HYTREL + PU	1
15	Guiding Band	Polyacetal	1
16	Guiding Bush	CSB-40	1
17	Magnet		1
18	Nut	Stainless Steel	1

Note:

Dia 32: Instead of Cushioning Plastic is used Cushioning yellow and instead of Cushioning Plastic Female Thread is used Cushioning yellow Female Thread. (Material:Brass)

Dia 125: Instead of Cushioning Plastic is used Cushioning Aluminium and instead of Cushioning Plastic Female Thread is used Cushioning Aluminium Female Thread. (Material: Anodized Aluminium)

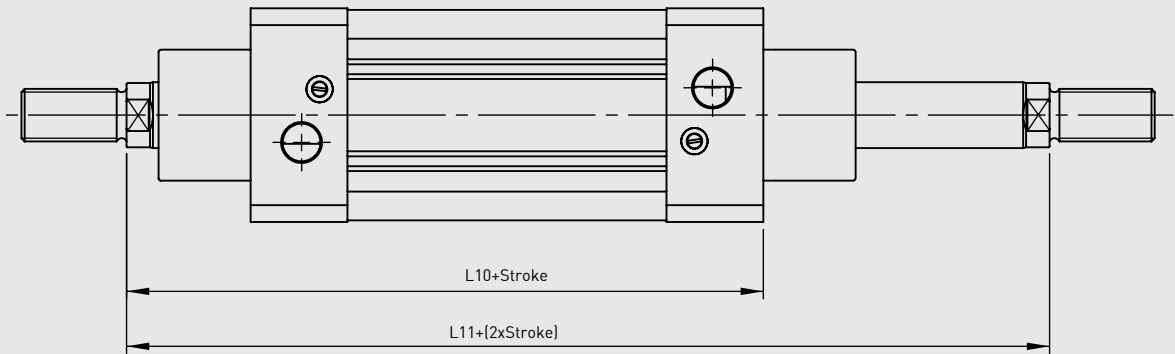
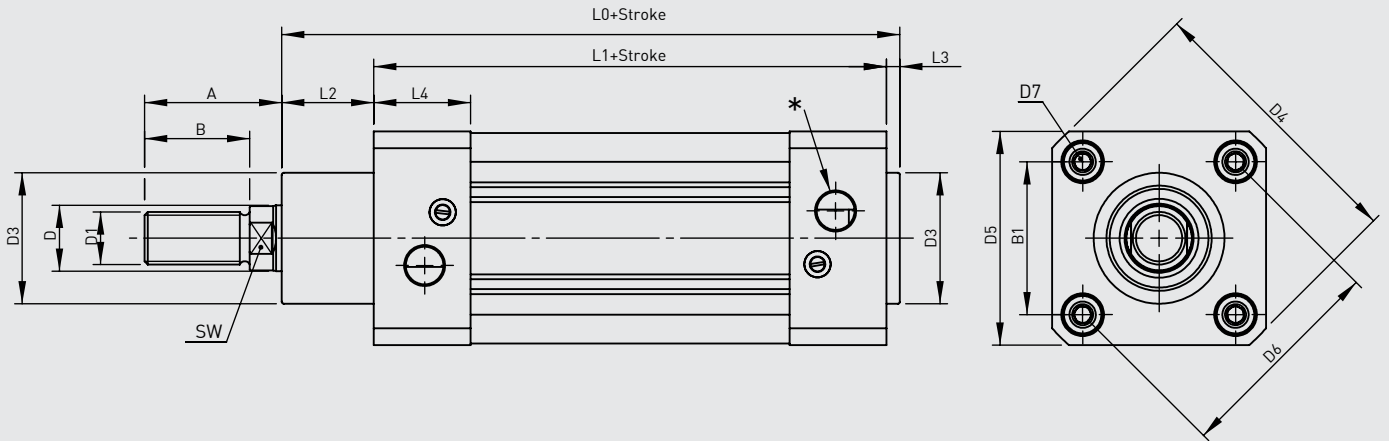

Cylinder Ø mm	A	B	B1	D Ø	D1	D3 Ø	D4	D5	D6 Ø	D7	L0	L1	L2	L3	L4	L10	L11	SW	*
32	30	22	32,5	12	M10x1.25	30	59	45	46	M6	116	94	18	4	25	120	146	10	G1/8"
40	34	24	38	16	M12x1.25	35	70,2	54	53,7	M6	129	105	20	4	27	135	165	13	G1/4"
50	41	32	46,5	20	M16x1.5	40	84,2	65	65,7	M8	138	106	28	4	29,5	143	180	17	G1/4"
63	42	32	56,5	20	M16x1.5	45	99,5	76	80	M8	152	121	27	4	34,5	158	195	17	G3/8"
80	52	40	72	25	M20x1.5	45	123,8	94	101,8	M10	167	128	34	4	35	174	220	22	G3/8"
100	52,5	40	89	25	M20x1.5	55	148,8	112	125,9	M10	182,5	138	38,5	4	38	189	240	22	G1/2"
125	73	54	110	32	M27x2	60	179,5	134	155,5	M12	213	160	46	6	44	225	290	27	G1/2"

FLM FLANGE MOUNTING

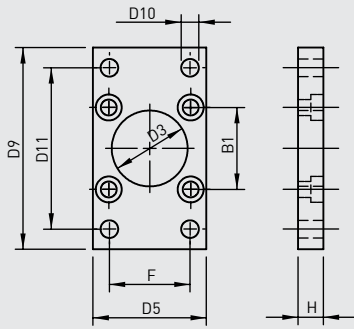

FMF FLANGE MOUNTING AT FRONT

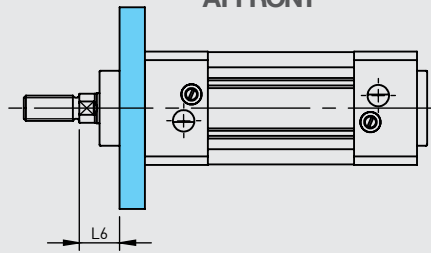

FMTR FLANGE MOUNTING AT REAR

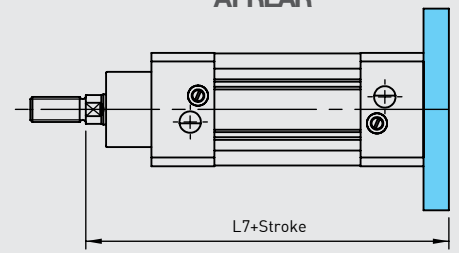

FM FOOT MOUNTING

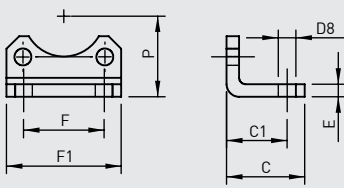

FM FOOT MOUNTING

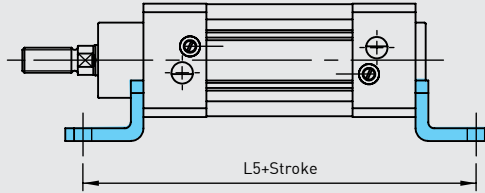

RC ROD CLEVIS

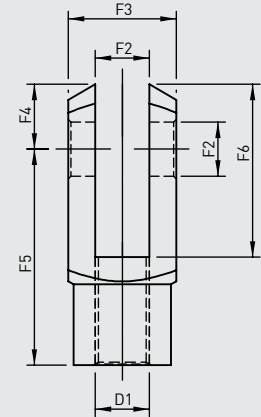

SF SWIVEL FLANGE

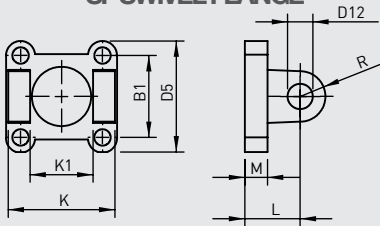

SF SWIVEL FLANGE

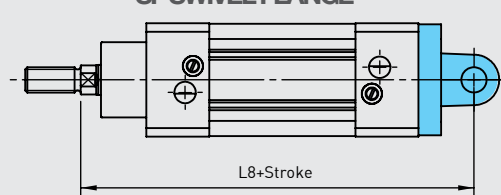

CFM CLEVIS FOOT MOUNTING

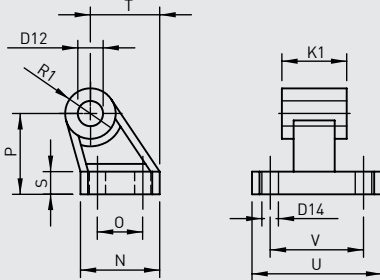

SFWCFM SWIVEL FLANGE WITH CLEVIS FOOT MOUNTING

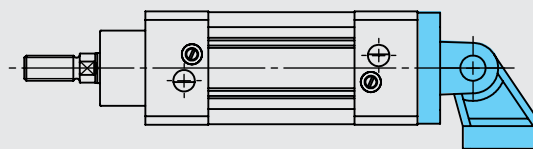

Cylinder Ø mm	B1	C	C1	D1	D3 Ø	D5	D8 Ø	D9	D10 Ø	D11	D12 Ø	D14 Ø	E	F	F1	F2 Ø	F3
32	32.5	30	24	M10x1.25	30	45	7	80	7	64	10	5.5	5	32	45.5	10	20
40	38	37	28	M12x1.25	35	54	10	90	9	72	12	5.5	5	36	54.5	12	24
50	46.5	41	32	M16x1.5	40	65	10	110	9	90	12	6.5	6	45	65	16	32
63	56.5	44	32	M16x1.5	45	76	10	120	9	100	16	6.5	6	50	76	16	32
80	72	56	41	M20x1.5	45	94	12	150	12	126	16	9	6	63	94	20	40
100	89	58	41	M20x1.5	55	112	14	175	14	150	20	9	6	75	112	20	40
125	110	67	45	M27x2	60	134	16	210	16	180	25	11	8	90	131	25	50

Cylinder Ø mm	F4	F5	F6	H	K	K1	L	L5	L6	L7	L8	M	N	O	P	R	R1	S	T	U	V
32	12	40	32	10	45	26	22	142	16	130	142	9	31	18	32	10	10	8	27.5	51	38
40	14	48	38	10	52	28	25	161	20	145	160	9	35	22	36	12	11	10	30.5	54	41
50	19	64	51	12	60	32	27	170	25	155	170	11	45	30	45	13	13	12	40.5	65	50
63	19	64	51	12	70	40	32	185	25	170	190	11	50	35	50	16	15	12	44.5	67	52
80	25	80	65	16	90	50	36	210	30	190	210	14	60	40	63	16	15	14	57	86	66
100	25	80	65	16	110	60	41	220	35	205	230	14	70	50	71	20	19	15	65	96	76
125	32	100	82	20	130	70	50	250	45	245	275	15	90	60	90	25	22.5	20	85	124	94

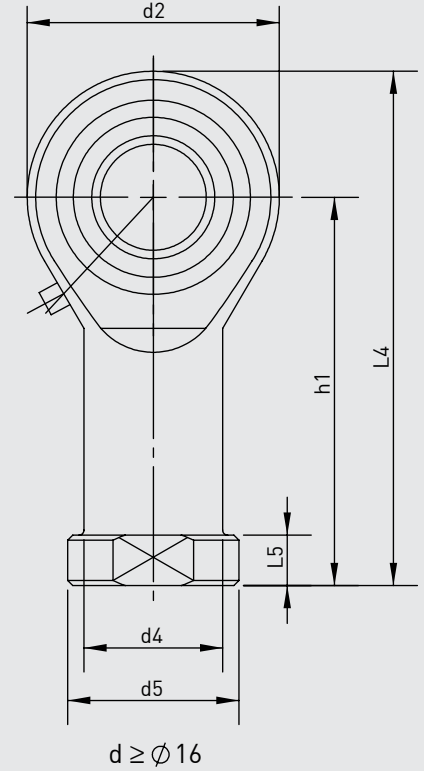
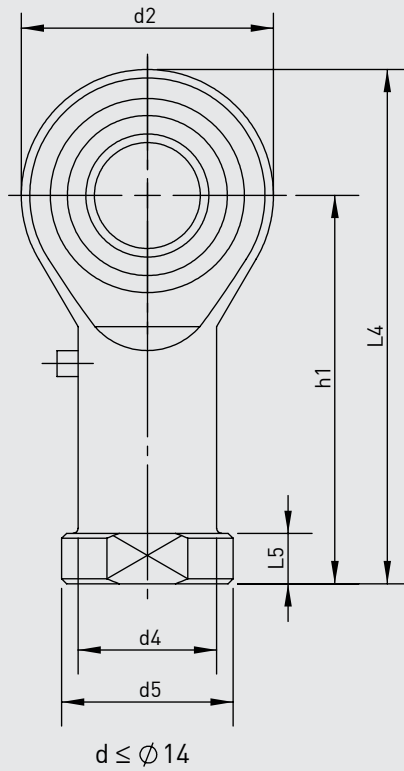
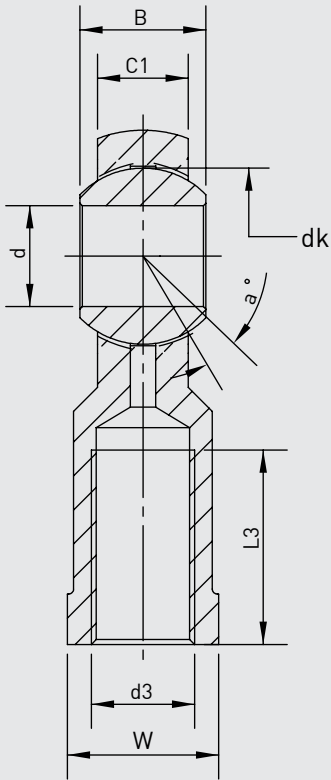

ISP-M SERIES
ISO 15552 - Ø32 - Ø125

Part No.	Dimensions (mm)													
	d	d3 6H	B	C1	w	L3 min	d2	L4	h1	L5	d4	d5	dk	a°
KMB 10-1	10	M10x1.25	14	10,5	17	20	26	56	43	6,5	15	19	19,05	13
KMB 12-1	12	M12x1.25	16	12	19	22	30	65	50	6,5	17,5	22	22,225	13
KMB 16-1	16	M16x1.5	21	15	22	28	40	84	64	8	22	27	28,575	15
KMB 20	20	M20x1.5	25	18	30	33	50	102	77	10	27,5	34	34,925	14
KMB 28	28	M27x2.0	35	24	41	48	66	136	103	14	37	46	47,6	15
KMB 30	30	M30x2.0	37	25	41	51	70	145	110	15	40	50	50,8	17

ISO 15552
PNEUMATIC CYLINDERS
PAC-Y SERIES Ø32 - Ø125

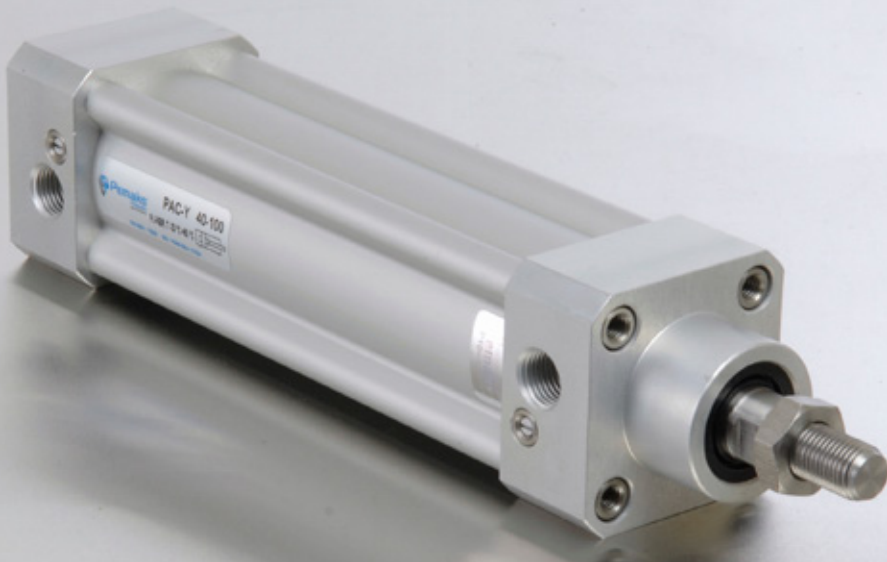



PAC-Y SERIES

ISO 15552 - Ø32 - Ø125

CUSHIONING CYLINDER

ELOXAL PLATE AND
SPECIAL ROD SEAL PROVIDING
HYGIENE AND LONG WORKING LIFE.

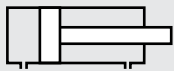

PAC: DOUBLE ACTING CYLINDER

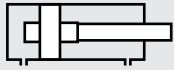

PAC-Y: DOUBLE ACTING CYLINDER
WITH CUSHIONING



PAC-D: DOUBLE ACTING CYLINDER
WITH DOUBLE ROD

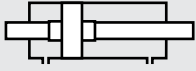

PAC-YD: DOUBLE ACTING CYLINDER
WITH CUSHIONING AND DOUBLE ROD

Example of order:

PAC-Y
Product Code

050-0100
Cylinder Ø
Stroke

SF
Cylinder
Mountings

M2
Variants from
Standard System

VARIANTS FROM STANDARD SYSTEM:

R1: Stainless Steel Piston Rod (SS 304-SS 316)

R5: Piston Rod as CK45 (Hard chrome plated)

M1: Extended male Piston Rod Thread

M2: Female Piston Rod Thread

M3: Special Piston Rod Thread

M4: Extended Piston Rod

K1: Seals for Max. 150°C (Viton)

K2: Piston Rod Seal NBR + PA

K3: Seals NBR

K4: Piston Rod Seal Viton

Force:

Cylinder Ø mm	Rod Ø mm	Thrust and traction forces(6 Bar)	
		Thrust Force (N)	Traction Force (N)
32 12	482	415	
40 16	754	633	
50 20	1178	990	
63 20	1870	1682	
80 25	3016	2721	
100 25	4712	4418	
125 32	7363	6881	

Working Fluid:

Filtered and lubricated air

Operating Temperature Range:

NBR + Polyurethane (PU): (-20°C) - (+80°C)

Viton (FKM) : (-30°C) - (+180°C)

Max. Work Pressure:

10 Bar

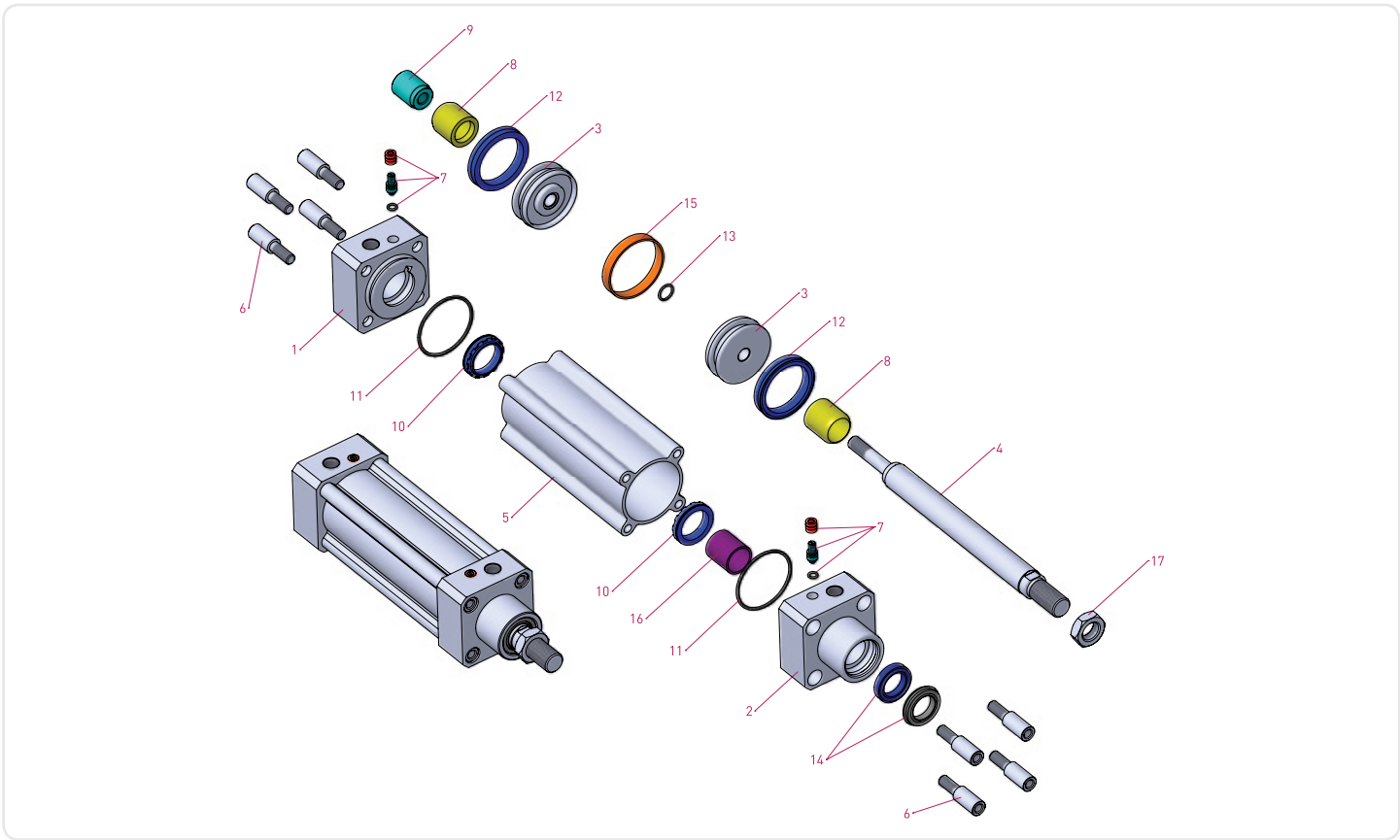
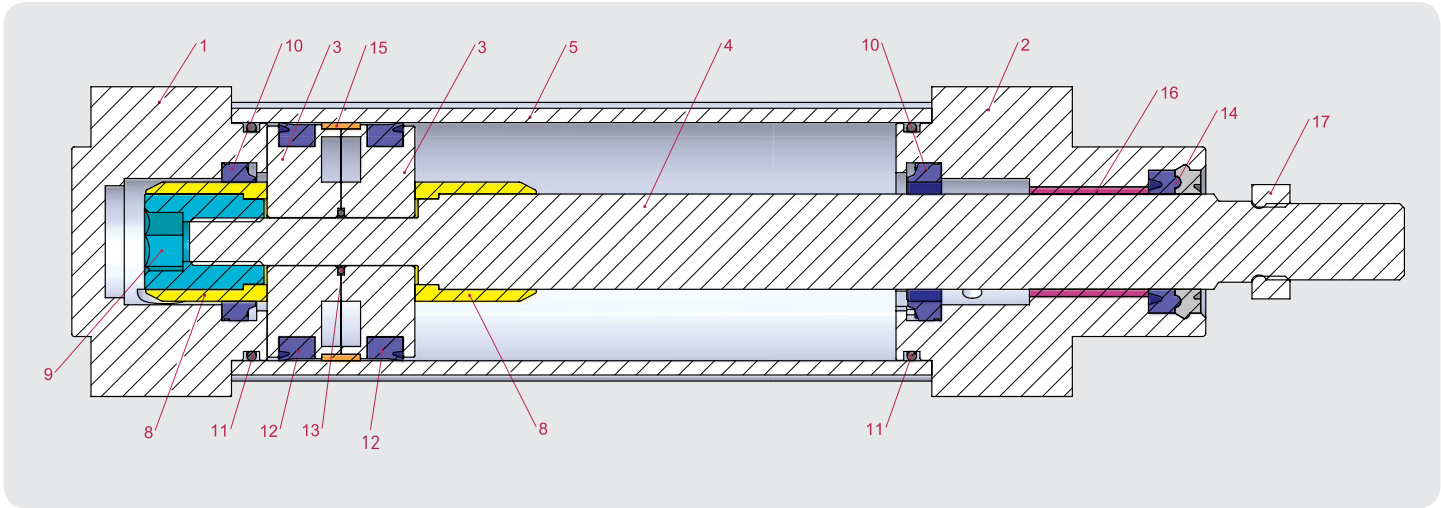

No	MATERIAL NAME	CHARACTERISTIC	PC.
1	Rear Head	6082 Al. + Eloxal Plated	1
2	Front Head	6082 Al. + Eloxal Plated	1
3	Middle Piston	Aluminium	2
4	Piston Rod	X20 Cr13 Hard Chrome Plated	1
5	Tube	Al Mg Si 0,5 + Eloxal Plated	1
6	Bolt	Stainless Steel	8
7	Cushioning Screw	6082 Al. + Eloxal + AISI 303 NBR	2
8	Cushioning Plastic	Polyacetal	2
9	Cushioning Fem. Thread	Galvanized Steel	1
10	Cushioning Seal	PU	2
11	Head O-ring	NBR	2

No	MATERIAL NAME	CHARACTERISTIC	PC.
12	Piston Seal	PU	2
13	Middle Piston O-ring	NBR	1
14	Rod Seal	HYTREL + PU	1
15	Guiding Band	Polyacetal	1
16	Guiding Bush	CSB-40	1
17	Nut	Stainless Steel	1

Note:
 Dia 32: Instead of Cushioning Plastic is used Cushioning yellow and instead of Cushioning Plastic Female Thread is used Cushioning yellow Female Thread. (Material:Brass)
 Dia 125: Instead of Cushioning Plastic is used Cushioning Aluminium and instead of Cushioning Plastic Female Thread is used Cushioning Aluminium Female Thread. (Material: Anodized Aluminium)

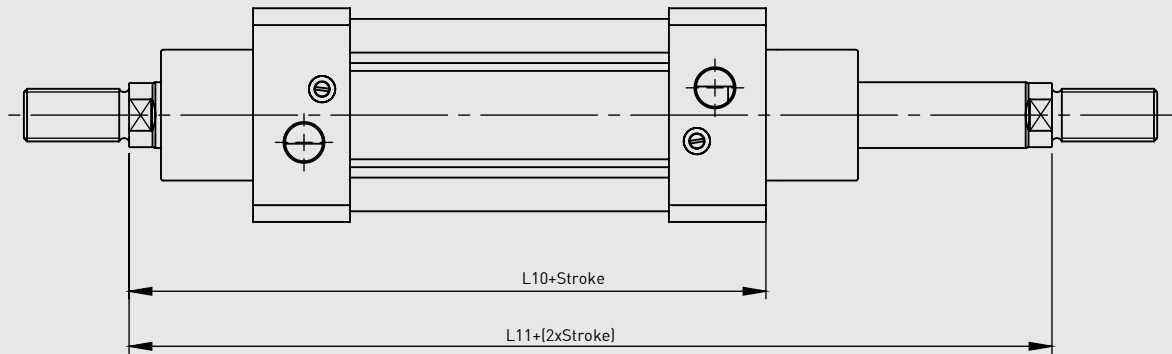
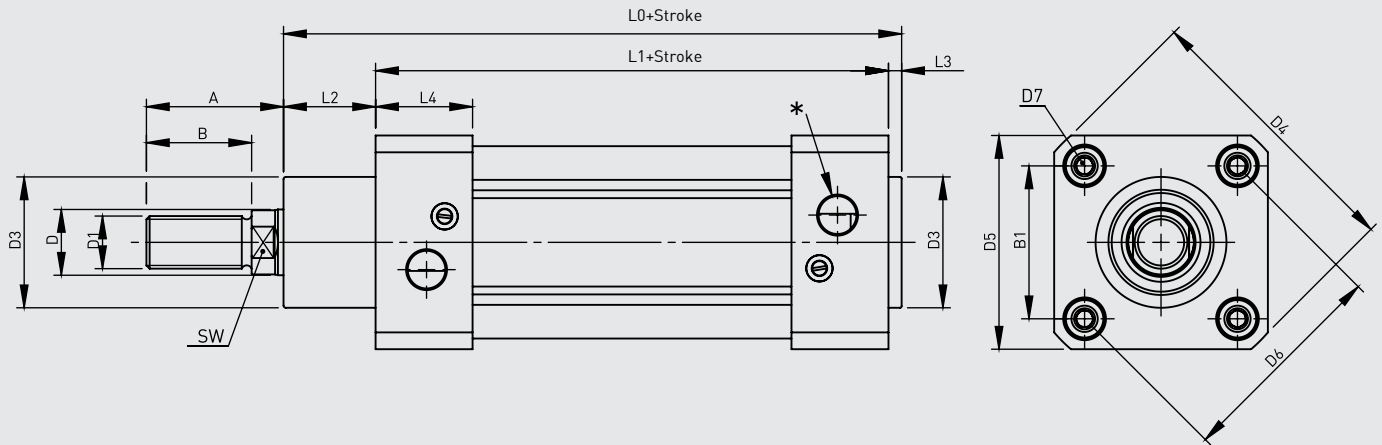

Cylinder Ø mm	A	B	B1	D Ø	D1	D3 Ø	D4	D5	D6 Ø	D7	L0	L1	L2	L3	L4	L10	L11	SW	*
32	30	22	32,5	12	M10x1.25	30	59	45	46	M6	116	94	18	4	25	120	146	10	G1/8''
40	34	24	38	16	M12x1.25	35	70,2	54	53,7	M6	129	105	20	4	27	135	165	13	G1/4''
50	41	32	46,5	20	M16x1.5	40	84,2	65	65,7	M8	138	106	28	4	29,5	143	180	17	G1/4''
63	42	32	56,5	20	M16x1.5	45	99,5	76	80	M8	152	121	27	4	34,5	158	195	17	G3/8''
80	52	40	72	25	M20x1.5	45	123,8	94	101,8	M10	167	128	34	4	35	174	220	22	G3/8''
100	52,5	40	89	25	M20x1.5	55	148,8	112	125,9	M10	182,5	138	38,5	4	38	189	240	22	G1/2''
125	73	54	110	32	M27x2	60	179,5	134	155,5	M12	213	160	46	6	44	225	290	27	G1/2''

FLM FLANGE MOUNTING

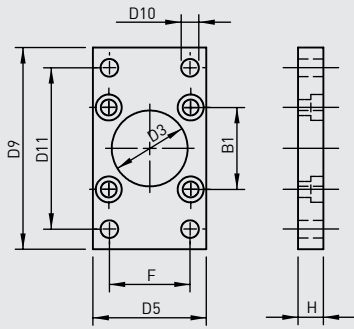

FMF FLANGE MOUNTING AT FRONT

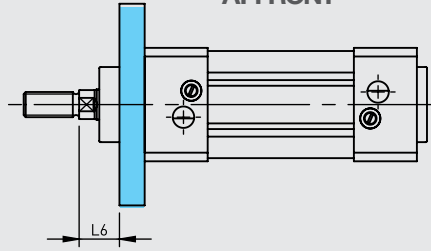

FMTR FLANGE MOUNTING AT REAR

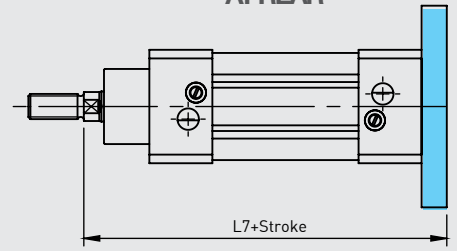

FM FOOT MOUNTING

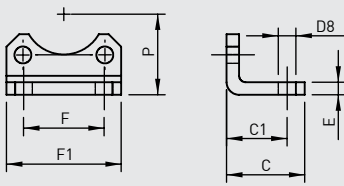

FM FOOT MOUNTING

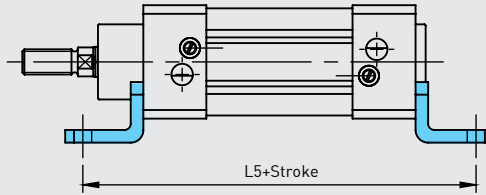

RC ROD CLEVIS

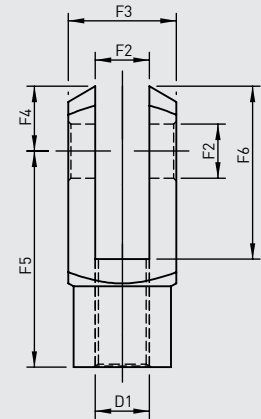

SF SWIVEL FLANGE

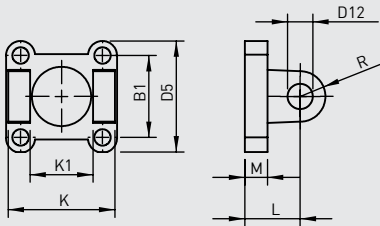

SF SWIVEL FLANGE

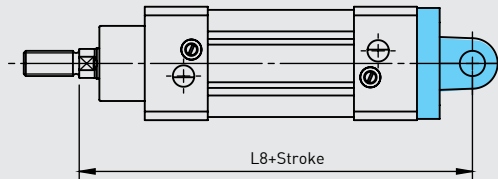

CFM CLEVIS FOOT MOUNTING

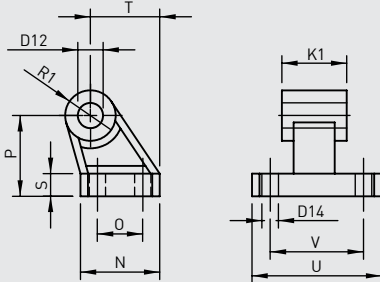

SFWCFM SWIVEL FLANGE WITH CLEVIS FOOT MOUNTING

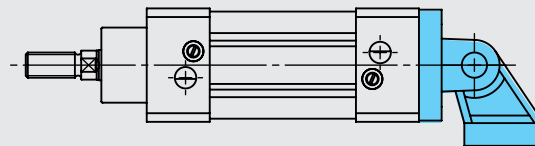

Cylinder Ø mm	B1	C	C1	D1	D3 Ø	D5	D8 Ø	D9	D10 Ø	D11	D12 Ø	D14 Ø	E	F	F1	F2 Ø	F3
32	32.5	30	24	M10x1.25	30	45	7	80	7	64	10	5.5	5	32	45.5	10	20
40	38	37	28	M12x1.25	35	54	10	90	9	72	12	5.5	5	36	54.5	12	24
50	46.5	41	32	M16x1.5	40	65	10	110	9	90	12	6.5	6	45	65	16	32
63	56.5	44	32	M16x1.5	45	76	10	120	9	100	16	6.5	6	50	76	16	32
80	72	56	41	M20x1.5	45	94	12	150	12	126	16	9	6	63	94	20	40
100	89	58	41	M20x1.5	55	112	14	175	14	150	20	9	6	75	112	20	40
125	110	67	45	M27x2	60	134	16	210	16	180	25	11	8	90	131	25	50

Cylinder Ø mm	F4	F5	F6	H	K	K1	L	L5	L6	L7	L8	M	N	O	P	R	R1	S	T	U	V
32	12	40	32	10	45	26	22	142	16	130	142	9	31	18	32	10	10	8	27.5	51	38
40	14	48	38	10	52	28	25	161	20	145	160	9	35	22	36	12	11	10	30.5	54	41
50	19	64	51	12	60	32	27	170	25	155	170	11	45	30	45	13	13	12	40.5	65	50
63	19	64	51	12	70	40	32	185	25	170	190	11	50	35	50	16	15	12	44.5	67	52
80	25	80	65	16	90	50	36	210	30	190	210	14	60	40	63	16	15	14	57	86	66
100	25	80	65	16	110	60	41	220	35	205	230	14	70	50	71	20	19	15	65	96	76
125	32	100	82	20	130	70	50	250	45	245	275	15	90	60	90	25	22.5	20	85	124	94

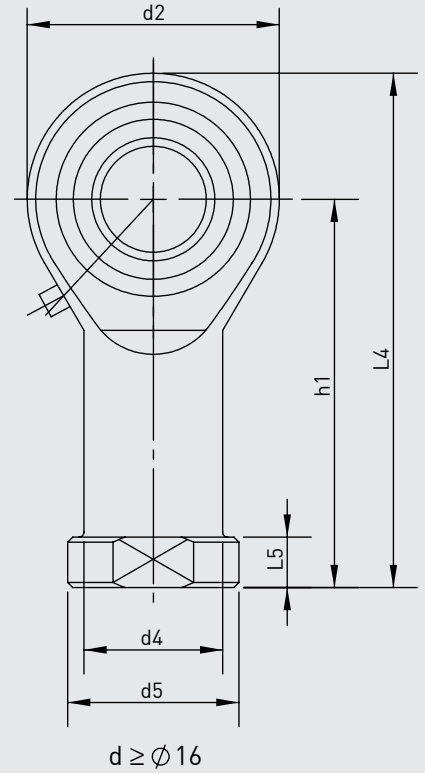
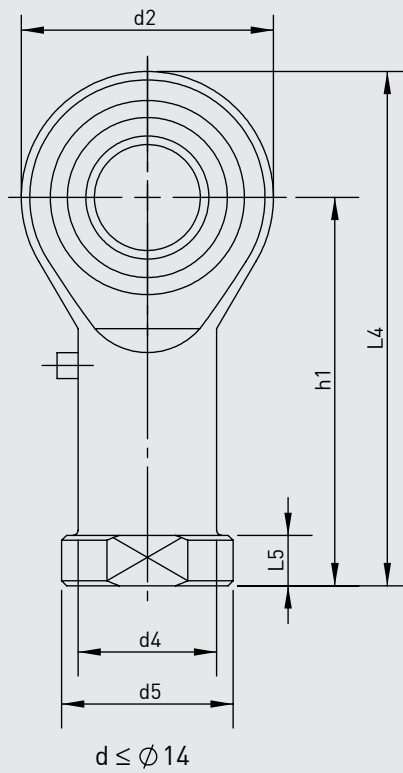
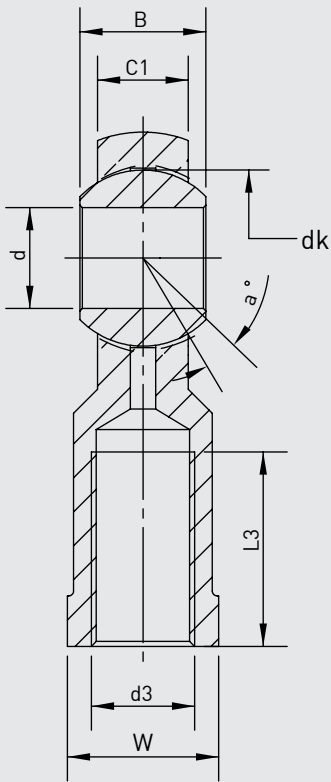

PAC-Y SERIES
ISO 15552 - Ø32 - Ø125

Part No.	Dimensions (mm)													
	d	d3 6H	B	C1	w	L3 min	d2	L4	h1	L5	d4	d5	dk	a°
KMB 10-1	10	M10x1.25	14	10,5	17	20	26	56	43	6,5	15	19	19,05	13
KMB 12-1	12	M12x1.25	16	12	19	22	30	65	50	6,5	17,5	22	22,225	13
KMB 16-1	16	M16x1.5	21	15	22	28	40	84	64	8	22	27	28,575	15
KMB 20	20	M20x1.5	25	18	30	33	50	102	77	10	27,5	34	34,925	14
KMB 28	28	M27x2.0	35	24	41	48	66	136	103	14	37	46	47,6	15
KMB 30	30	M30x2.0	37	25	41	51	70	145	110	15	40	50	50,8	17

ISO 15552
PNEUMATIC CYLINDERS
PMB SERIES Ø125 - Ø320

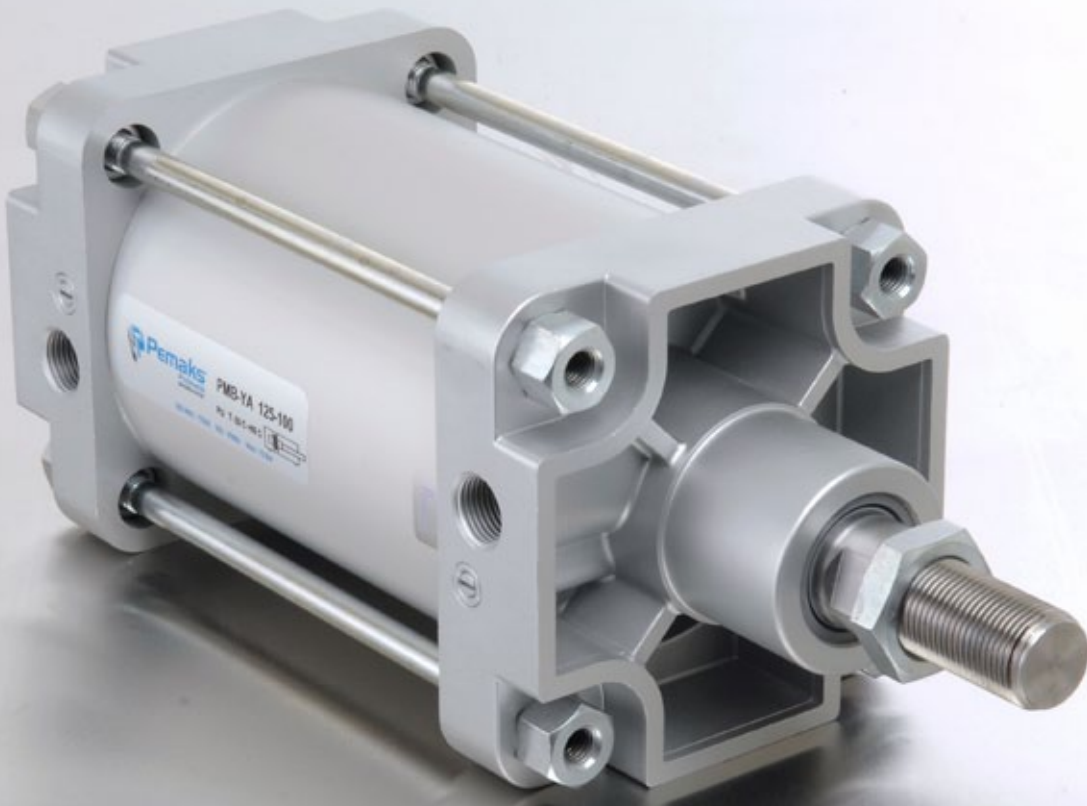



PMB SERIES

ISO 15552 - Ø125 - Ø320

ALUMINIUM TUBE CYLINDER WITH MAGNETIC AND CUSHIONING

STRONG STRUCTURE PROVIDING HIGH PERFORMANCES EVEN IN DIFFICULT ENVIRONMENTS.

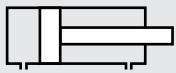

PMB: DOUBLE ACTING CYLINDER

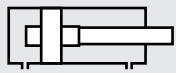

PMB-Y: DOUBLE ACTING CYLINDER WITH CUSHIONING

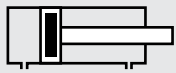

PMB-A: DOUBLE ACTING CYLINDER WITH MAGNETIC



PMB-D: DOUBLE ACTING CYLINDER WITH DOUBLE ROD

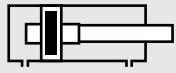

PMB-YA: DOUBLE ACTING CYLINDER WITH CUSHIONING AND MAGNETIC

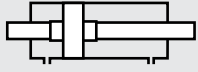

PMB-YD: DOUBLE ACTING CYLINDER WITH CUSHIONING AND DOUBLE ROD

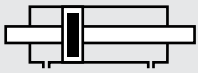

PMB-AD: DOUBLE ACTING CYLINDER WITH MAGNETIC AND DOUBLE ROD

Example of order:

PMB-YA

Product Code

160-0200

Cylinder Ø Stroke

SF RC

Cylinder Mountings

K1

Variants from Standard System

VARIANTS FROM STANDARD SYSTEM:

- R1: Stainless Steel Piston Rod (SS 304-SS 316)
- R2: Stainless Steel Tie Rods (SS 304-SS 316)
- R3: Stainless Steel Screws for Cylinder Covers (SS 304)
- R4: Stainless Steel Nut for Piston Rod (SS 304)
- R5: Piston Rod as CK45 (Hard chrome plated)
- M1: Extended male Piston Rod Thread
- M2: Female Piston Rod Thread
- M3: Special Piston Rod Thread
- M4: Extended Piston Rod
- K1: Seals for Max. 150°C (Viton)
- K2: Piston Rod Seal NBR + PA
- K3: Seals NBR
- K4: Piston Rod Seal Viton

Working Fluid:

Filtered and lubricated or filtered and not lubricated air

Operating Temperature Range:

Polyurethane (PU) : (-20°C) - (+80°C)

Viton (FKM) : (-30°C) - (+180°C)

Max. Work Pressure:

10 Bar

Force:

Cylinder Ø mm	Rod Ø mm	Thrust and traction forces(6 Bar)	
		ThrustForce (N)	Traction Force (N)
125	32	7360	6880
160	40	12064	11310
200	40	18850	18096
250	50	29450	28270
320	63	48250	46380

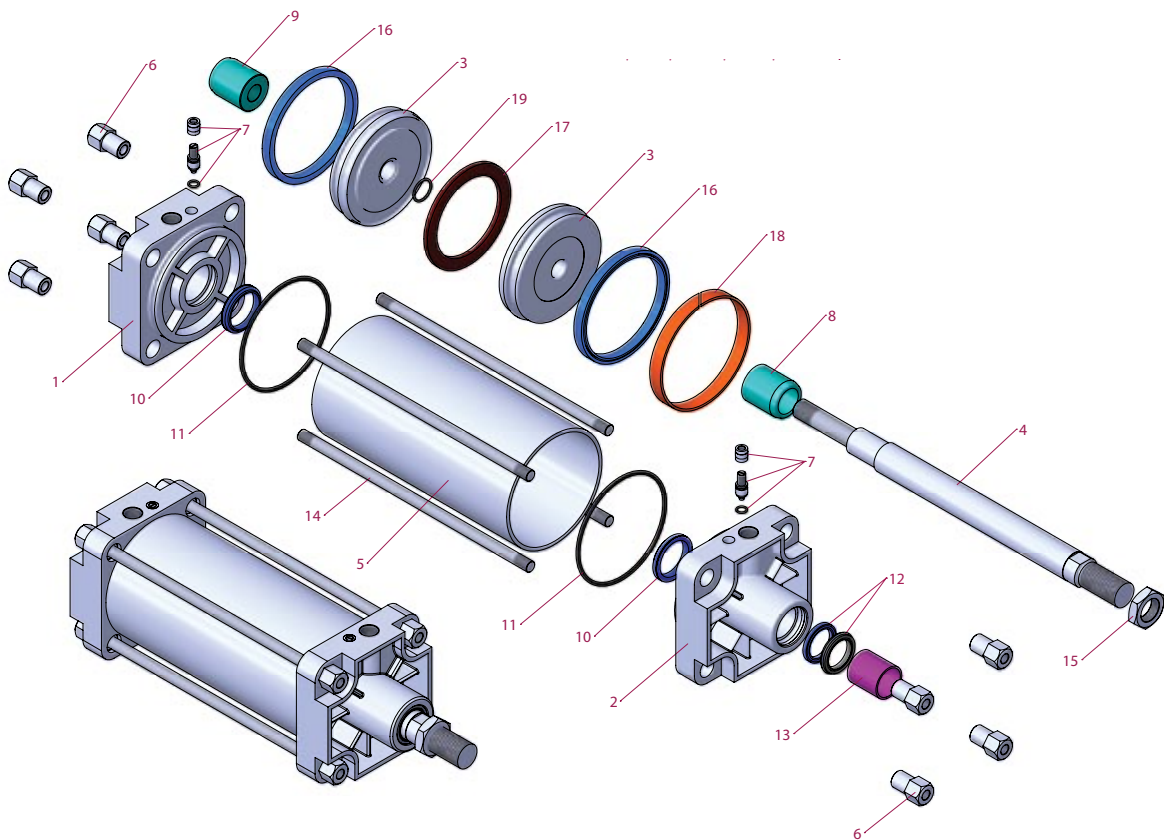
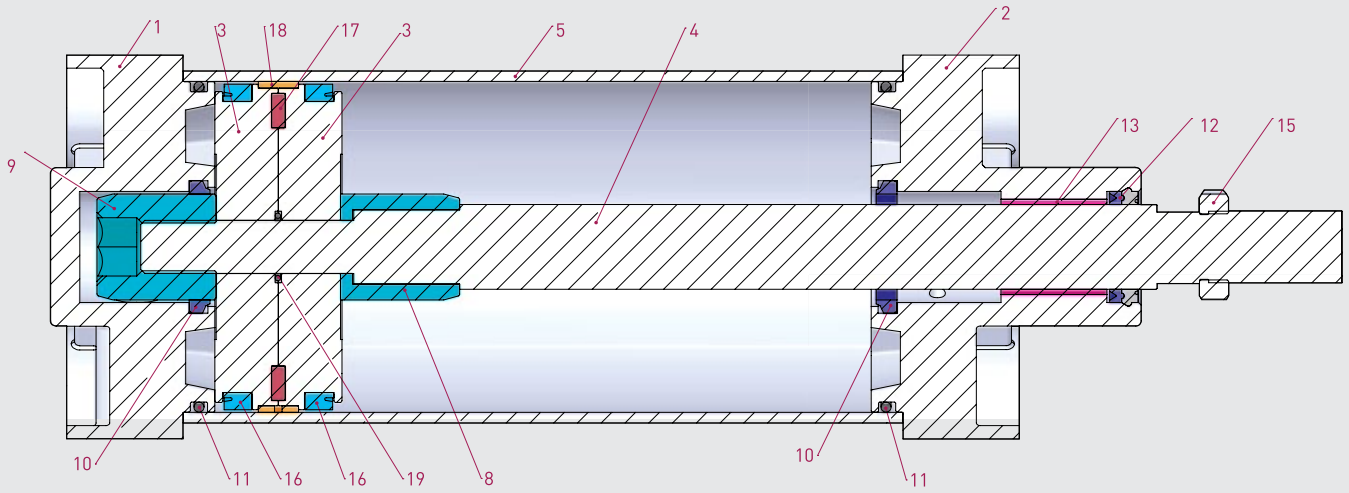

No	MATERIAL NAME	CHARACTERISTIC	PC.
1	Rear Head	Aluminium	1
2	Front Head	Aluminium	1
3	Middle Piston	Aluminium	2
4	Piston Rod	X20 Cr13 Hard Chrome Plated	1
5	Tube	Al Mg Si 0,5 + Eloxal Plated	1
6	T-Nut	Galvanized Steel	8
7	Cushioning Screw	6082 Al. + Eloxal + AISI 303 NBR	2
8	Cushioning Tube	Aluminium	1
9	Cushioning Fem. Thread	Aluminium	1
10	Cushioning Seal	PU	2
11	Head O-ring	NBR	2

No	MATERIAL NAME	CHARACTERISTIC	PC.
12	Rod Seal	HYTREL + PU	1
13	Guiding Bush	CSB-40	1
14	Tie-Rod	Galvanized Steel	4
15	Nut	Galvanized Steel	1
16	Piston Seal	PU	2
17	Magnet		1
18	Guiding Band	Polyacetal	1
19	Middle Piston O-ring	NBR	1

Note:

The Parts [Nr. 7,8,9,10] don't exist in the Models Without Cushioning. Fibre Nut and Washer exist instead of the Part Nr. 9

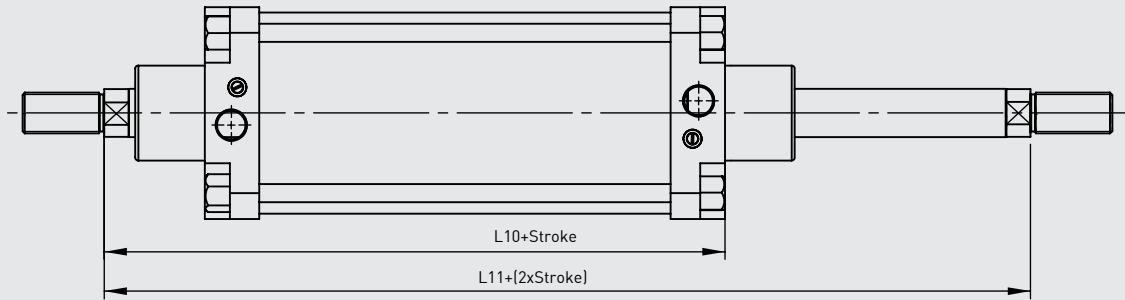
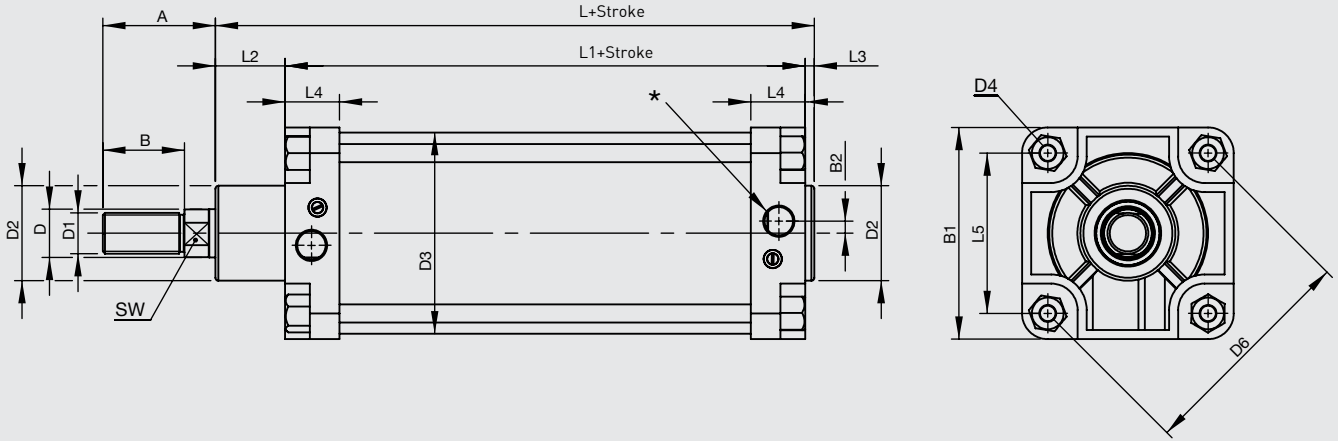

Cylinder Ø mm	A	B	B1	B2	D Ø	D1	D2 Ø	D3 Ø	D4	D6 Ø	L	L1	L2	L3	L4	L5	L10	L11	SW	*
125	73	54	145	11.5	32	M27x2	60	133	M12	155.5	213	160	46	6	44	110	225	290	27	G1/2"
160	97	72	186	13.5	40	M36x2	65	170	M16	198	243	180	55	6	47	140	260	340	36	G3/4"
200	102	72	220	13.5	40	M36x2	75	210	M16	247.5	253	180	65	6	47	175	275	370	36	G3/4"
250	122	84	270	14	50	M42x2	90	262	M20	311.1	281	200	69	10	51	220	305	410	46	G1"
320	134	96	340	20	63	M48x2	110	336	M24	381.8	314	220	82	10	56	270	340	460	55	G1"

FLM FLANGE MOUNTING

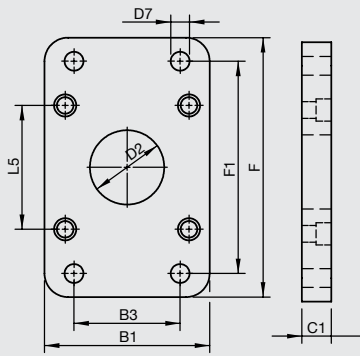

FLM FLANGE MOUNTING

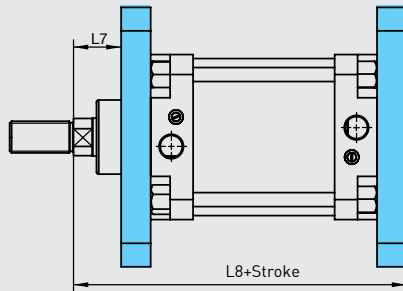

RC ROD CLEVIS

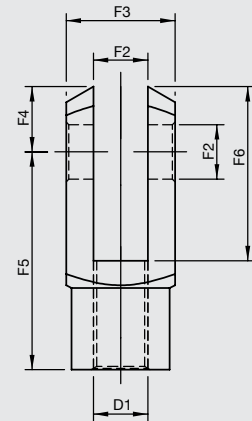

FM FOOT MOUNTING

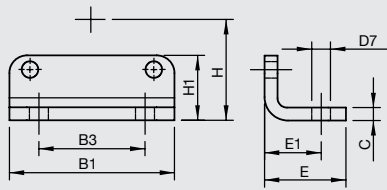

FM FOOT MOUNTING

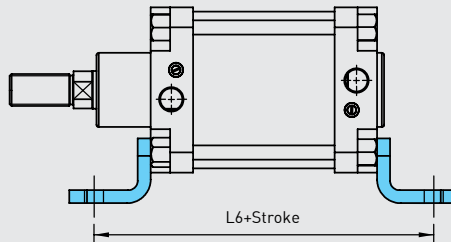

SF SWIVEL FLANGE

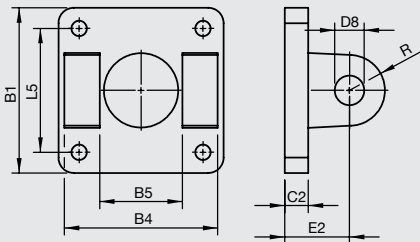

SF SWIVEL FLANGE

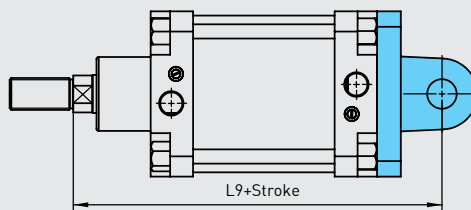

CTM CENTRAL TRUNNION MOUNTING

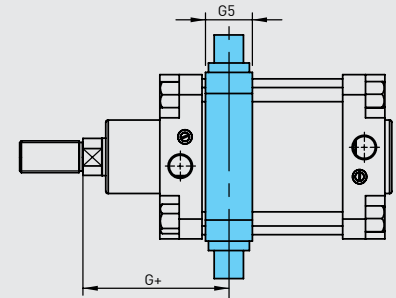

CFM CLEVIS FOOT MOUNTING

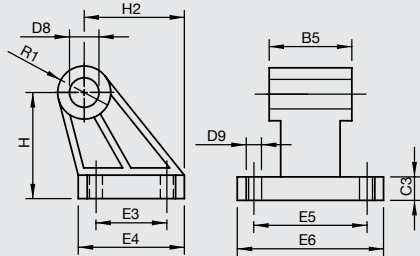

SFWCFM SWIVEL FLANGE WITH CLEVIS FOOT MOUNTING

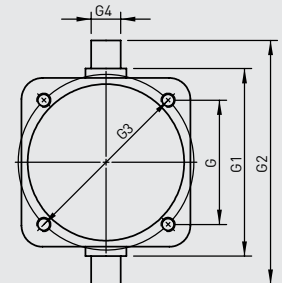
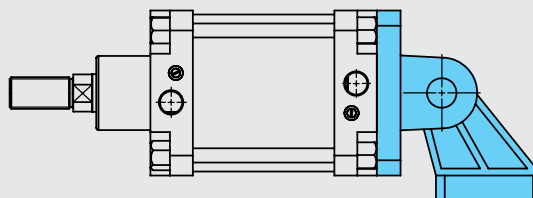

Cylinder Ø mm	B1	B3	B4	B5	C	C1	C2	C3	D1	D2 Ø	D7 Ø	D8 Ø	D9 Ø	E	E1	E2	E3	E4	E5	E6	F	F1	F2 Ø
125	145	90	130	70	8	20	20	20	M27x2	60	16	25	11	67	45	50	60	90	94	124	220	180	25
160	186	115	170	90	9	20	20	25	M36x2	65	18	30	14	87	60	55	88	126	118	156	280	230	35
200	220	135	170	90	12	25	25	30	M36x2	75	22	30	16	95	70	60	90	130	122	162	320	270	35
250	270	165	200	110	20	25	25	35	M42x2	90	26	40	20	105	75	70	110	160	150	200	390	330	40
320	340	200	220	120	23	30	30	40	M48x2	110	33	45	26	125	85	80	122	186	170	234	470	400	50

Cylinder Ø mm	F3	F4	F5	F6	G	G1	G2	G3	G4	G5	G+	H	H1	H2	L5	L6	L7	L8	L9	R	R1
125	50	32	100	82	110	160	210	155.5	25	38	128	90	55	85	110	250	45	245	275	30	22.5
160	70	44	144	116	140	200	264	198	32	48	151	115	70	116	140	300	60	280	315	32	31.5
200	70	44	144	116	175	250	314	247.5	32	48	166	135	80	125	175	320	70	300	335	35	31.5
250	80	52	168	148	220	320	400	311.1	40	60	189	165	100	153	220	350	80	330	375	45	40
320	90	58	192	169	270	400	500	381.8	50	68	210	200	120	182	270	390	90	370	420	54	45

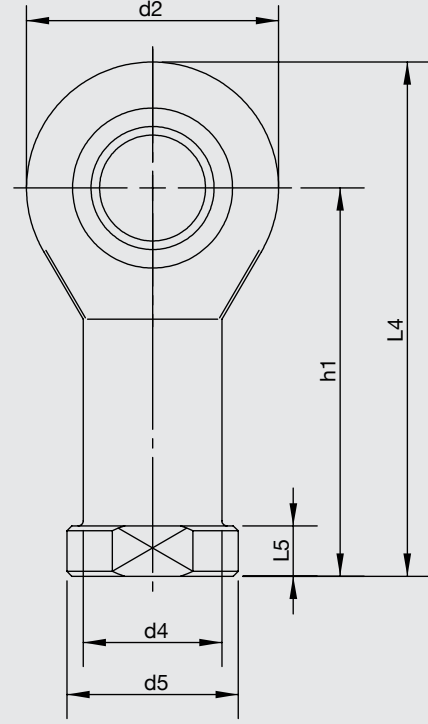
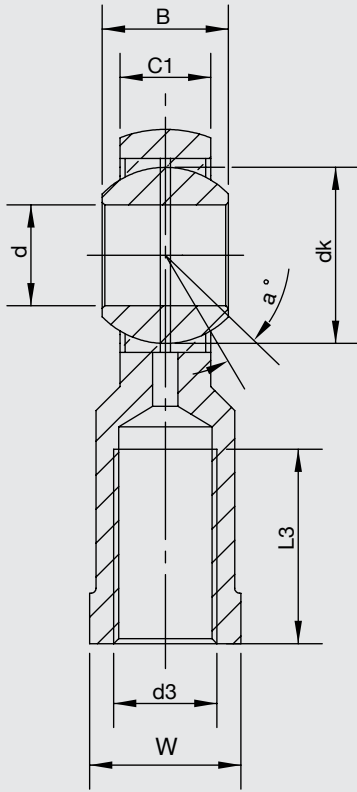

PMB SERIES

ISO 15552 - Ø125 - Ø320

Part No.	Dimensions (mm)													
	d	d3 6H	B	C1	w	L3 min	d2	L4	h1	L5	d4	d5	dk	a°
KMB 28	28	M27x2.0	35	24	41	48	66	136	103	14	37	46	47.6	15
KMB 30	30	M30x2.0	37	25	41	51	70	145	110	15	40	50	50.8	17
KMB 35 UK	35	M36x3.0	25	21	50	60	82	166	125	15	47	58	47	6
KMB 40 UK	40	M39x3.0	28	23	55	65	92	188	142	18	52	65	53	7
KMB 50 UK	50	M45x3.0	35	30	65	68	112	216	160	20	62	75	66	6

PMB Ø 125

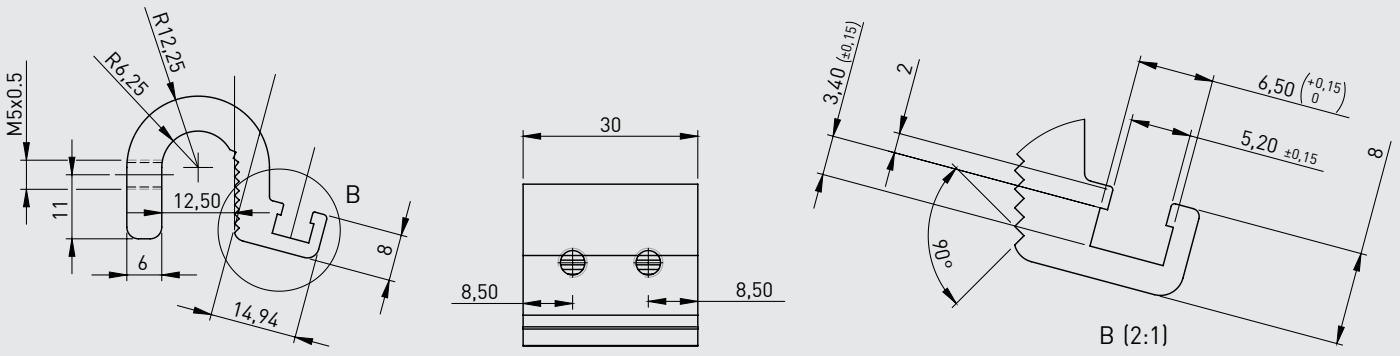

PMB Ø 160

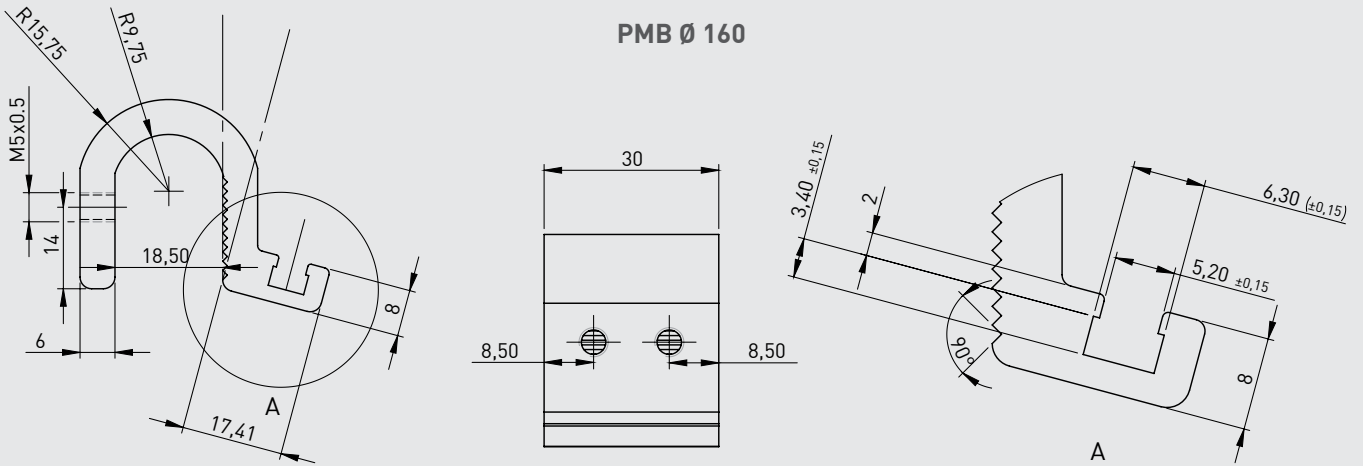

PMB Ø 200

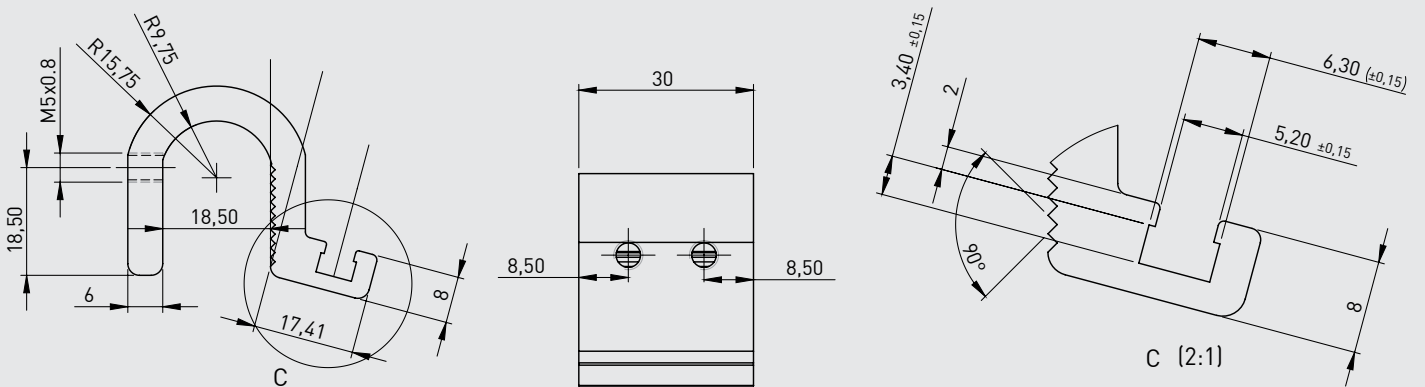

PMB Ø 250-320

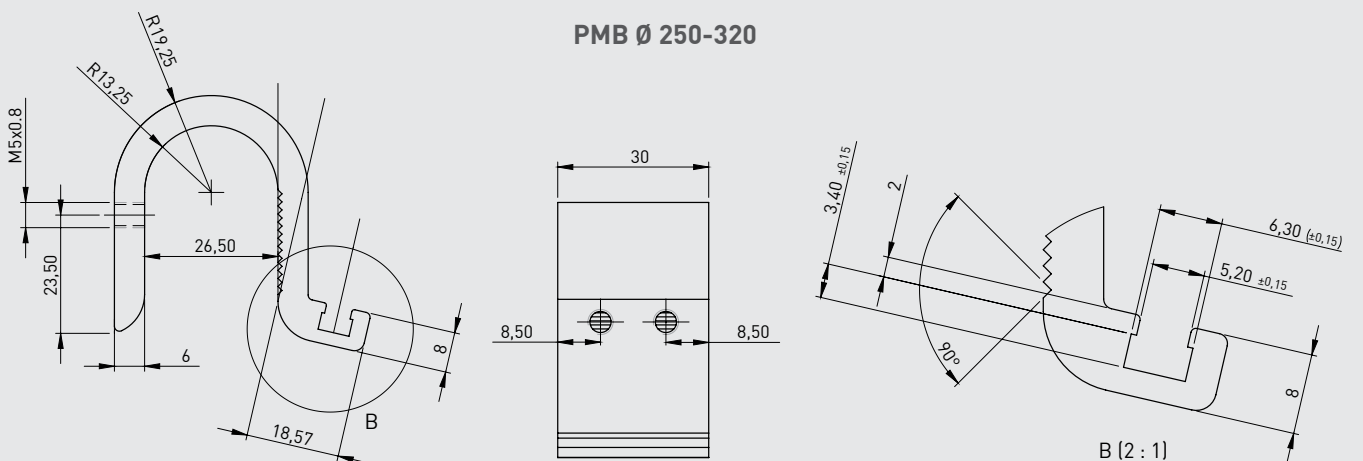

CETOP RP 53P-43P
PNEUMATIC CYLINDERS
PNS SERIES Ø125 - Ø320



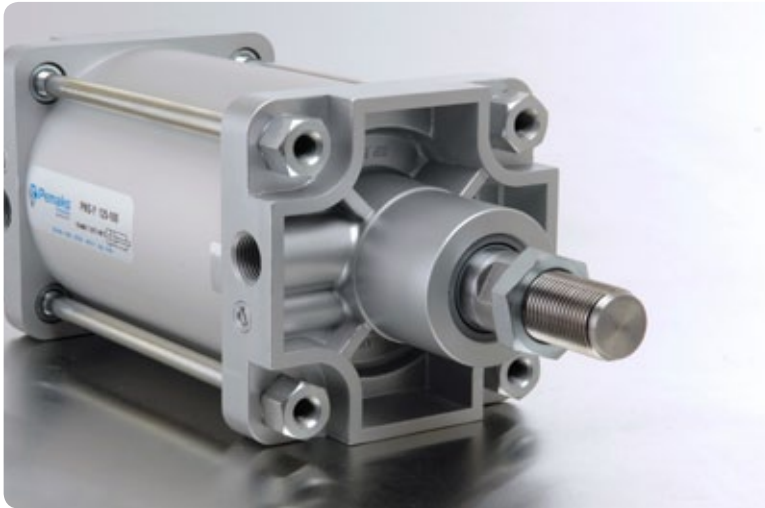

PNS SERIES

CETOP RP 53P - Ø125 - Ø320

CUSHIONING CYLINDER
WITH ALUMINIUM TUBE

MAXIMUM SEAL PERFORMANCE
BECAUSE OF ELOXAL PLATE

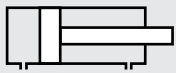

PNS: DOUBLE ACTING CYLINDER

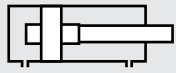

PNS-Y: DOUBLE ACTING CYLINDER
WITH CUSHIONING



PNS-D: DOUBLE ACTING CYLINDER
WITH DOUBLE ROD

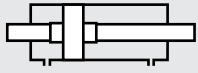

PNS-YD: DOUBLE ACTING CYLINDER
WITH CUSHIONING AND DOUBLE ROD

Example of order:

PNS-Y
Product Code

125-0200
Cylinder Ø
Stroke

SFWCFM
Cylinder
Mountings

K1 M2
Variants from
Standard System

VARIANTS FROM STANDARD SYSTEM:

- R1: Stainless Steel Piston Rod (SS 304-SS 316)
- R2: Stainless Steel Tie Rods (SS 304-SS 316)
- R3: Stainless Steel Screws for Cylinder Covers (SS 304)
- R4: Stainless Steel Nut for Piston Rod (SS 304)
- M1: Extended male Piston Rod Thread
- M2: Female Piston Rod Thread
- M3: Special Piston Rod Thread
- M4: Extended Piston Rod
- K1: Seals for Max. 150°C (Viton)
- K2: Piston Rod Seal NBR + PA
- K3: Seals NBR
- K4: Piston Rod Seal Viton

Working Fluid:

Filtered and lubricated air

Operating Temperature Range:

NBR+Polyurethane (PU) : (-20°C) - (+80°C)
Viton (FKM) : (-30°C) - (+180°C)

Max. Work Pressure:

10 Bar

Force:

Cylinder Ø mm	Rod Ø mm	Thrust and traction forces (6 Bar)	
		Thrust Force (N)	Traction Force (N)
125	32	7360	6880
160	45	12064	11110
200	45	18850	17890
250	50	29450	28270
320	63	48250	46380

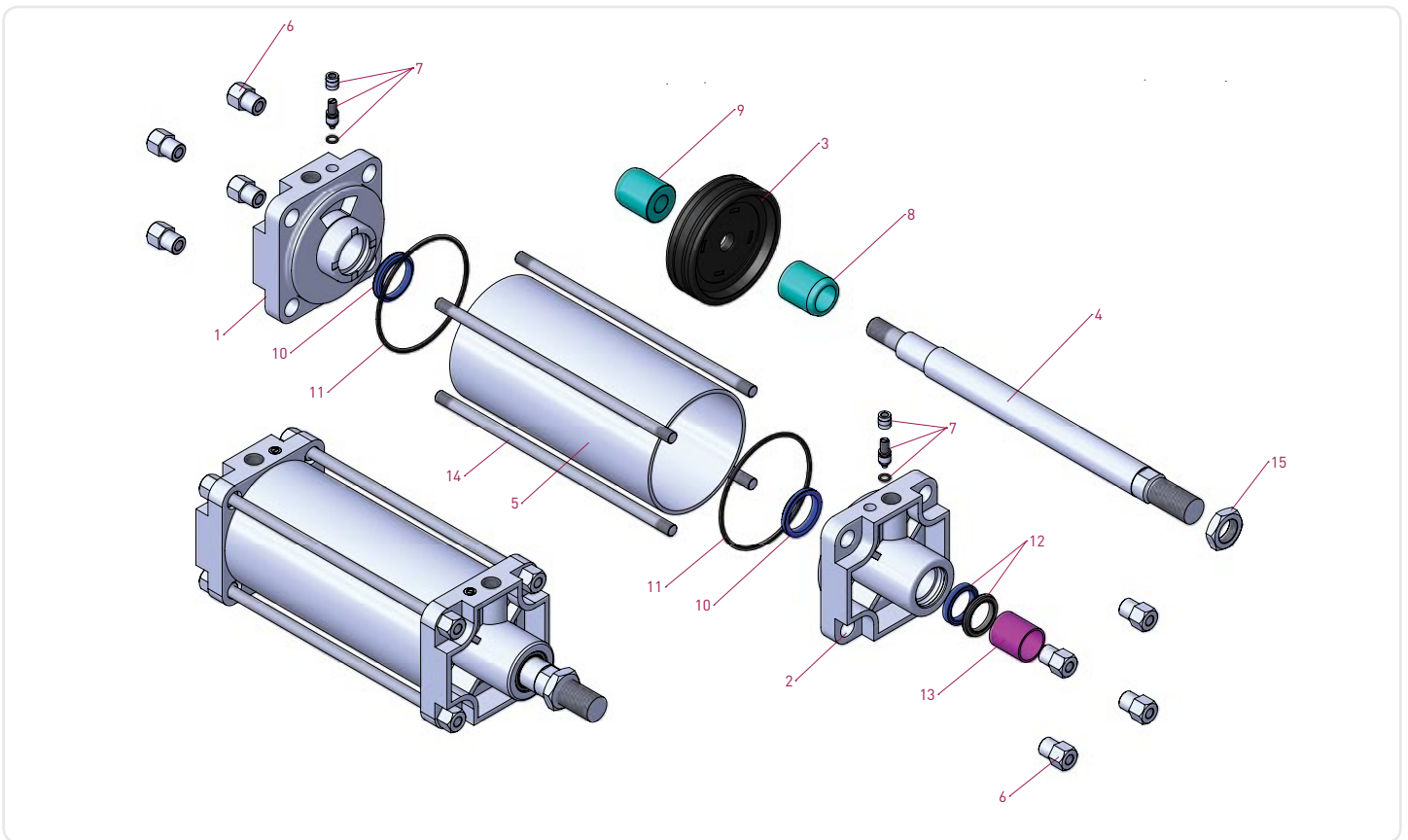
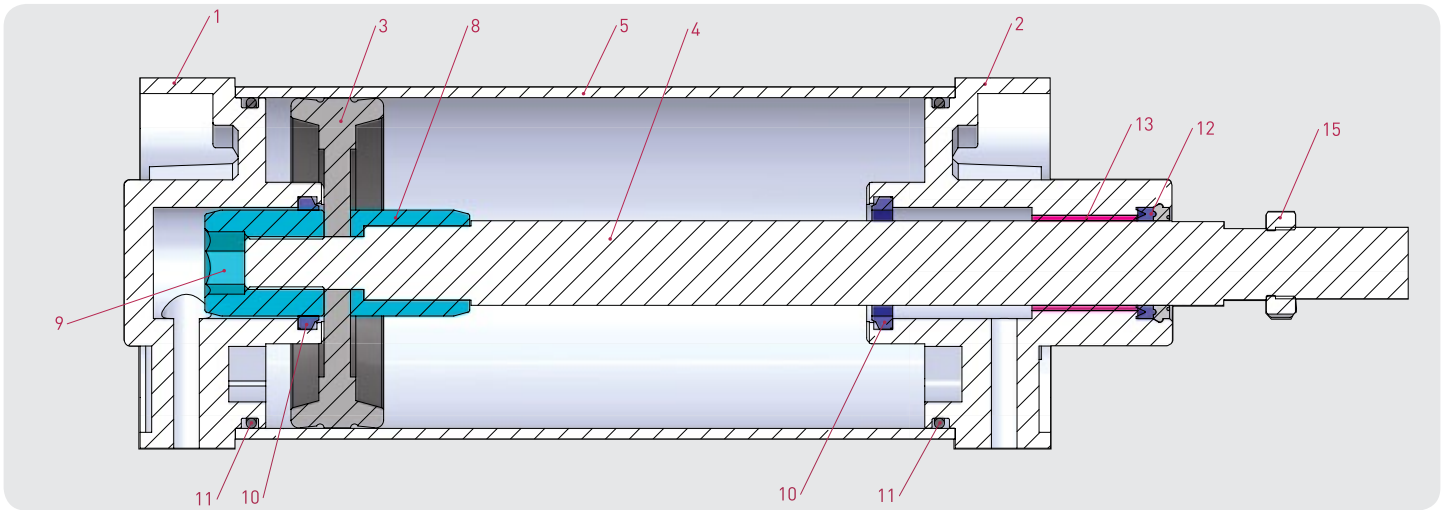

No	MATERIAL NAME	CHARACTERISTIC	PC.
1	Rear Head	Aluminium	1
2	Front Head	Aluminium	1
3	Piston Seal	NBR	1
4	Piston Rod	CK45 Hard Chrome Plated	1
5	Tube	Al Mg Si 0,5+Eloxal Plated	1
6	T-Nut	Galvanized Steel	8
7	Cushioning Screw	6082 Al. + Eloxal + AISI 303 NBR	2
8	Cushioning Tube	Aluminium	1
9	Cushioning Fem. Thread	Aluminium	1
10	Cushioning Seal	PU	2
11	Head O-ring	NBR	2

No	MATERIAL NAME	CHARACTERISTIC	PC.
12	Rod Seal	HYTREL + PU	1
13	Guiding Bush	CSB-40	1
14	Tie-Rod	Galvanized Steel	4
15	Nut	Galvanized Steel	1

Note:
The Parts (Nr. 7,8,9,10) don't exist in the Models Without Cushioning. Fibre Nut and Washer exist instead of the Part Nr. 9

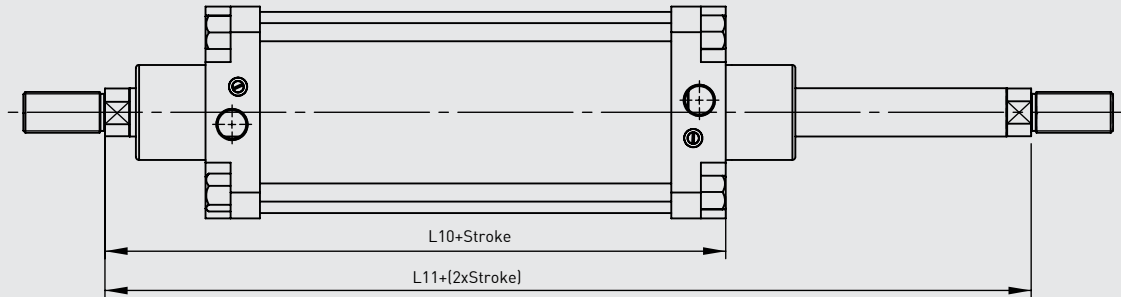
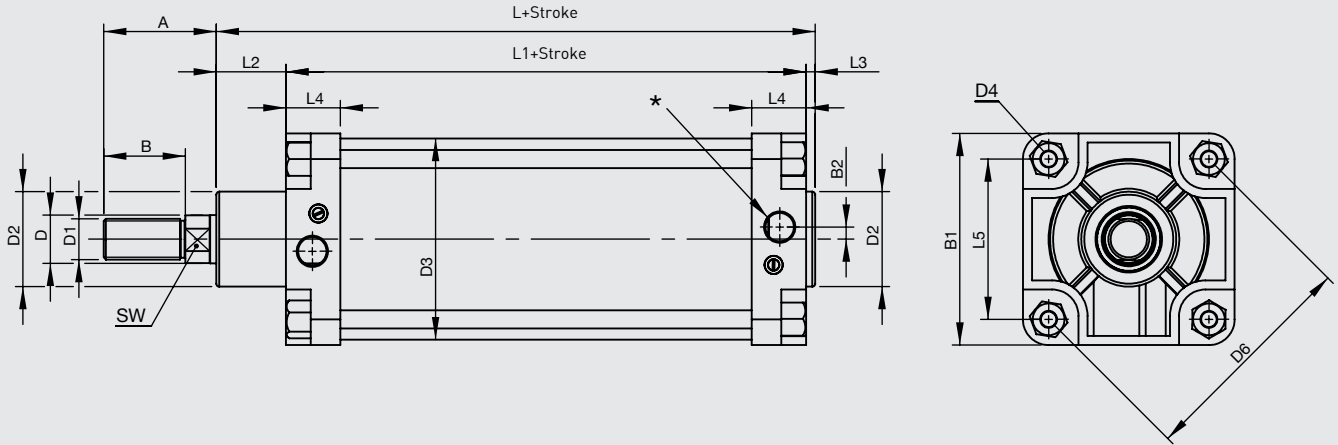

Cylinder Ø mm	A	B	B1	B2	D Ø	D1	D2 Ø	D3 Ø	D4	D6 Ø	L	L1	L2	L3	L4	L5	L10	L11	SW	*
125	70	48	140	15	32	M27x2	63	133	M12	150	208	150	48	6	36	106	220	290	27	G1/2"
160	102	72	180	22	45	M36x2	80	170	M14	190	235	170	55	10	46	134,4	255	340	41	G3/4"
200	102	72	220	25	45	M36x2	80	210	M16	234	257	180	65	12	46	165,5	275	370	41	G3/4"
250	114	84	270	25	50	M42x2	100	262	M20	288	289	200	75	14	50	203,7	305	410	46	G1"
320	126	96	340	30	63	M48x2	110	336	M24	360	326	220	90	16	56	254,6	340	460	55	G1"

FLM FLANGE MOUNTING

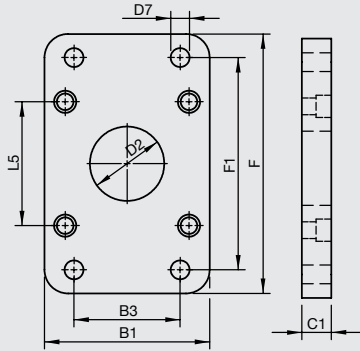

FLM FLANGE MOUNTING

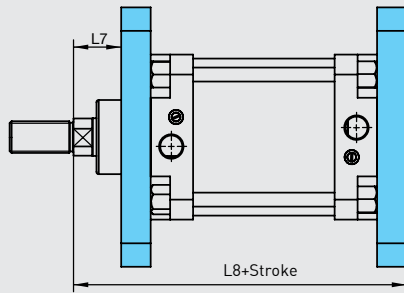

RC ROD CLEVIS

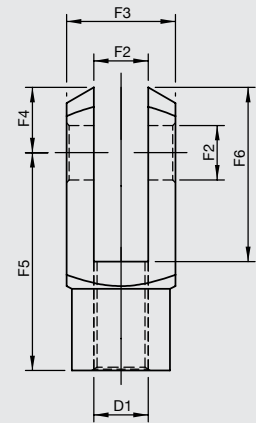

FM FOOT MOUNTING

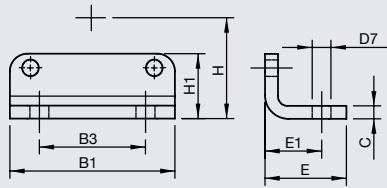

FM FOOT MOUNTING

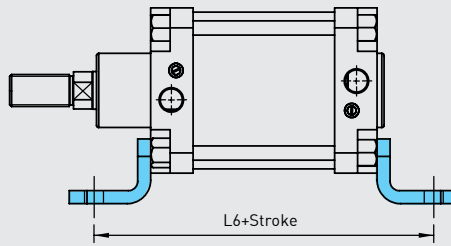

CTM CENTRAL TRUNNION MOUNTING

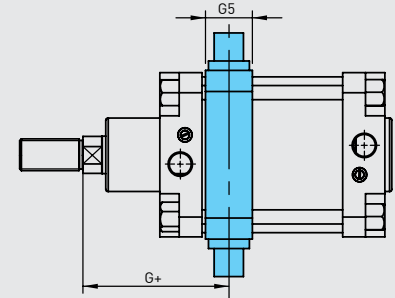

SF SWIVEL FLANGE

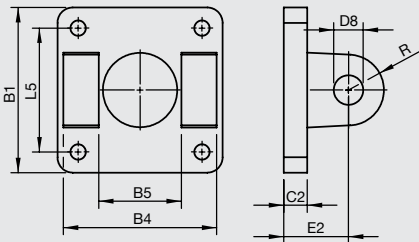

SF SWIVEL FLANGE

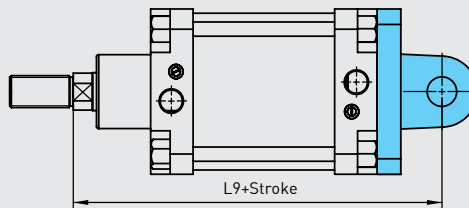

CFM CLEVIS FOOT MOUNTING

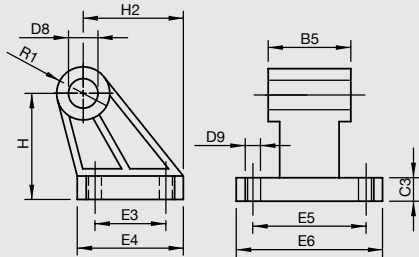

SFWCFM SWIVEL FLANGE WITH CLEVIS FOOT MOUNTING

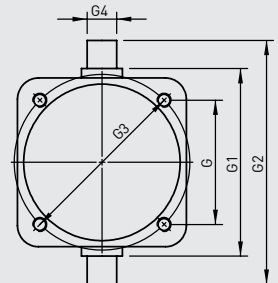
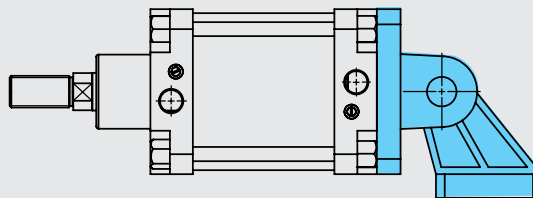

Cylinder Ø mm	B1	B3	B4	B5	C	C1	C2	C3	D1	D2 Ø	D7 Ø	D8 Ø	D9 Ø	E	E1	E2	E3	E4	E5	E6	F	F1	F2 Ø
125	140	90	130	70	11	25	20	20	M27x2	63	16	25	11	69	50	55	60	90	94	124	220	180	25
160	180	115	170	90	13	25	22	25	M36x2	80	18	30	14	87	65	60	88	126	118	156	280	230	35
200	220	135	170	90	15	25	25	30	M36x2	80	22	30	16	95	70	60	90	130	122	162	320	270	35
250	270	165	200	110	20	25	25	35	M42x2	100	26	40	20	105	75	70	110	160	150	200	390	330	40
320	340	200	220	120	23	30	30	40	M48x2	110	33	45	26	125	85	80	122	186	170	234	470	400	50

Cylinder Ø mm	F3	F4	F5	F6	G	G1	G2	G3	G4	G5	G+	H	H1	H2	L5	L6	L7	L8	L9	R	R1
125	50	32	100	82	106	160	210	150	25	38	125	90	55	85	106	250	45	245	275	30	22,5
160	70	44	144	116	134,4	200	264	190	32	48	155	115	70	116	134,4	300	60	280	315	32	31,5
200	70	44	144	116	165,5	250	314	234	32	48	165	135	80	125	165,5	320	70	300	335	35	31,5
250	80	52	168	148	203,7	320	400	288	40	62	186	165	100	153	203,7	350	80	330	375	45	40
320	90	58	192	169	254,6	400	500	360	50	68	210	200	120	182	254,6	390	90	370	420	54	45

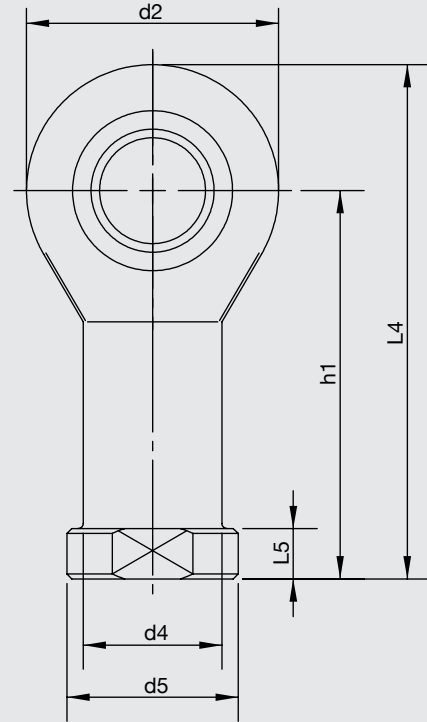
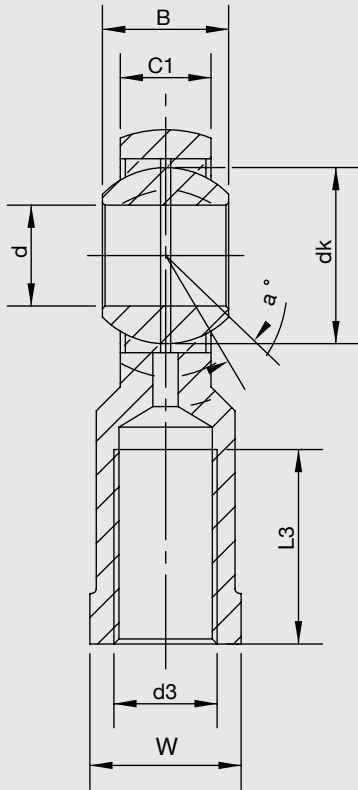

PNS SERIES
CETOP RP 53P - Ø125 - Ø320

Part No.	Dimensions (mm)													
	d	d3 6H	B	C1	w	L3 min	d2	L4	h1	L5	d4	d5	dk	a°
KMB 28	28	M27x2.0	35	24	41	48	66	136	103	14	37	46	47,6	15
KMB 30	30	M30x2.0	37	25	41	51	70	145	110	15	40	50	50,8	17
KMB 35 UK	35	M36x3.0	25	21	50	60	82	166	125	15	47	58	47	6
KMB 40 UK	40	M39x3.0	28	23	55	65	92	188	142	18	52	65	53	7
KMB 50 UK	50	M45x3.0	35	30	65	68	112	216	160	20	62	75	66	6

**CETOP RP 53P-43P
PNEUMATIC CYLINDERS
PNS SERIES Ø32 - Ø100**





PNS SERIES

CETOP RP 43P - Ø32 - Ø100

CUSHIONING CYLINDER
WITH STEEL TUBE

PNS IS ALSO AVAILABLE WITH HIGH
TEMPERATURE ENDURANCE SEALS
AND THE FAVORITE REQUIRE IN THE
MARKET SINCE 25 YEARS

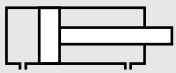

PNS: DOUBLE ACTING CYLINDER

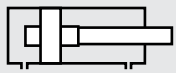

PNS-Y: DOUBLE ACTING CYLINDER
WITH CUSHIONING

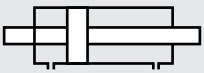

PNS-D: DOUBLE ACTING CYLINDER
WITH DOUBLE ROD

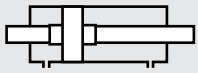

PNS-YD: DOUBLE ACTING CYLINDER
WITH CUSHIONING AND DOUBLE ROD

Example of order:

PNS-Y
Product Code

032-0100
Cylinder Ø
Stroke

FM
Cylinder
Mountings

K4
Variants from
Standard System

VARIANTS FROM STANDARD SYSTEM:

R1: Stainless Steel Piston Rod (SS 304-SS 316)

R4: Stainless Steel Nut for Piston Rod (SS 304)

M1: Extended male Piston Rod Thread

M2: Female Piston Rod Thread

M3: Special Piston Rod Thread

M4: Extended Piston Rod

K1: Seals for Max. 150°C (Viton)

K2: Piston Rod Seal NBR + PA

K3: Seals NBR

K4: Piston Rod Seal Viton

Force:

Cylinder Ø mm	Rod Ø mm	Thrust and traction forces (6 Bar)	
		Thrust Force (N)	Traction Force (N)
32	12	482	415
40	16	754	633
50	20	1178	990
63	20	1870	1682
80	25	3016	2721
100	25	4712	4418

Working Fluid:

Filtered and lubricated air

Operating Temperature Range:

NBR+Polyurethane (PU) : (-20°C) - (+80°C)

Viton (FKM) : (-30°C) - (+180°C)

Max. Work Pressure:

10 Bar

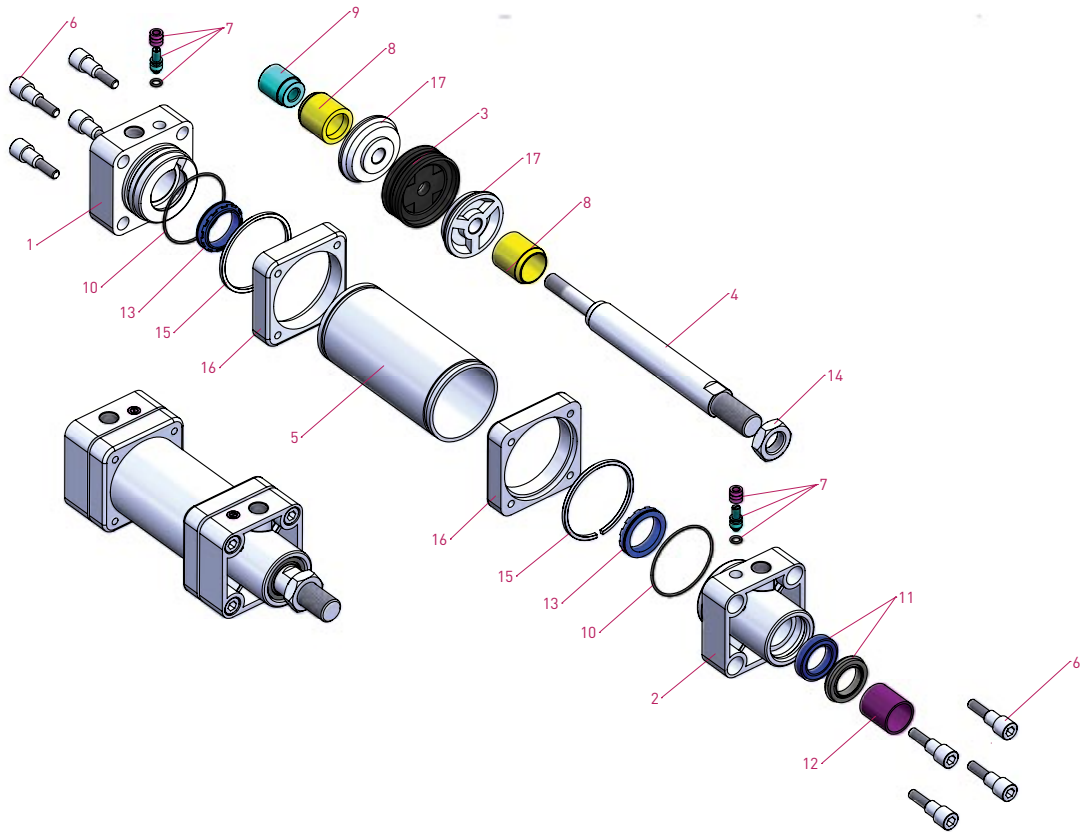
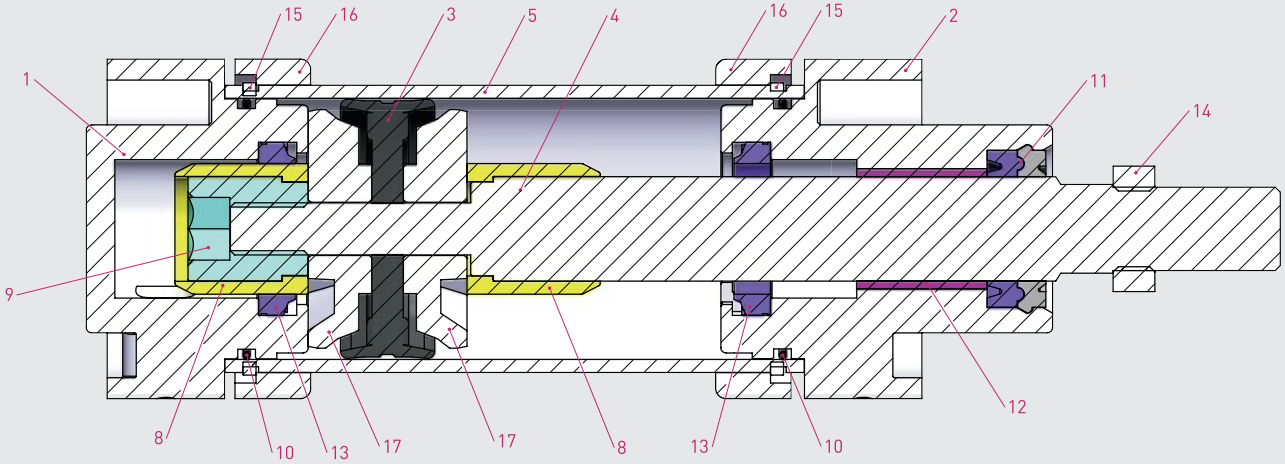

No	MATERIAL NAME	CHARACTERISTIC	PC.
1	Rear Head	Aluminium	1
2	Front Head	Aluminium	1
3	Piston Seal	NBR	1
4	Piston Rod	CK45 Hard Chrome Plated	1
5	Tube	St 52,3 H10 Steel	1
6	Bolt	Galvanized Steel	8
7	Cushioning Screw	6082 AL. + Eloxal + AISI 303 NBR	2
8	Cushioning Plastic	Polyacetal	2
9	Cushioning Fem. Thread	Galvanized Steel	1
10	Head O-ring	NBR	2
11	Rod Seal	HYTREL + PU	1

No	MATERIAL NAME	CHARACTERISTIC	PC.
12	Guiding Bush	CSB-40	1
13	Cushioning Seal	PU	2
14	Nut	Galvanized Steel	1
15	Circle Mounting Ret. Ring	Steel	2
16	Circle Mounting	Aluminium	2
17	Piston Seal Washer	Aluminium	2

Note:

Dia 32: Instead of Cushioning Plastic is used Cushioning yellow and instead of Cushioning Plastic Female Thread is used Cushioning yellow Female Thread. (Material:Brass)

The Piston Seal Washers exist only as Ø32, Ø40, Ø50

The Parts (Nr. 7,8,9,13) don't exist in the Models Without Cushioning. Fibre Nut and Washer exist instead of the Part Nr. 9

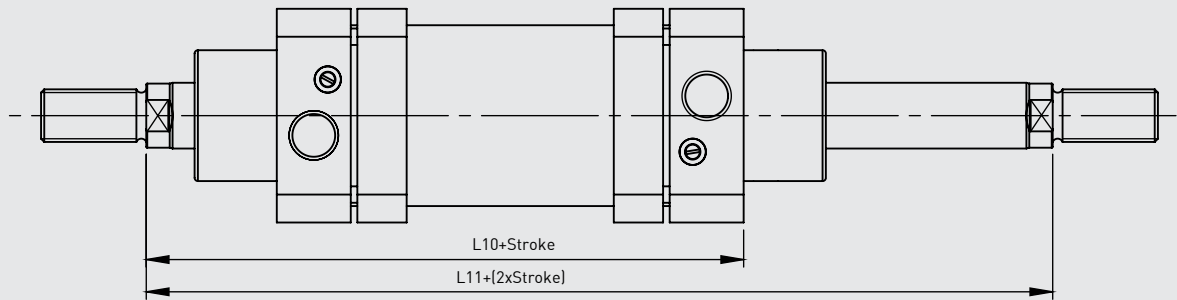
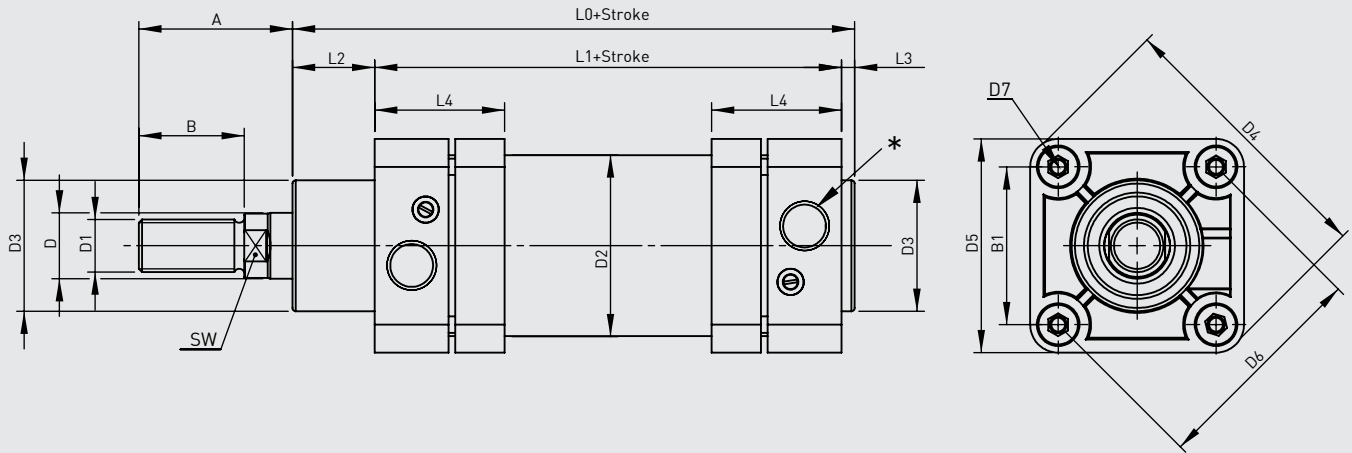

Cylinder Ø mm	A	B	B1	D Ø	D1	D2 Ø	D3 Ø	D4	D5	D6 Ø	D7	L0	L1	L2	L3	L4	L10	L11	SW	*
32	30	20	32,5	12	M10x1.25	36	30	58	45	46	M5	114	94	16	4	40	120	146	10	G1/8"
40	34	24	39,6	16	M12x1.25	45	35	71	54	56	M5	130,5	105	20	4	38	135	165	13	G1/4"
50	44	32	48	20	M16x1.5	55	40	85	65	68	M6	136	106	25	4	40	143	180	17	G1/4"
63	44	32	59,4	20	M16x1.5	68	42	105	80	84	M6	149	115	28	4	46	155	195	17	G3/8"
80	54	40	70,7	25	M20x1.5	86	48	125	96	100	M8	164	124	34	4	50	172	220	22	G3/8"
100	53	40	93,4	25	M20x1.5	107	52	166	126	132	M8	181	134	40	4	56	187	240	22	G1/2"

FLM FLANGE MOUNTING

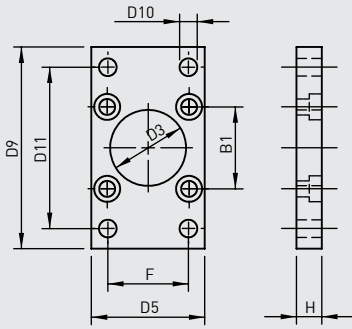

FLM FLANGE MOUNTING

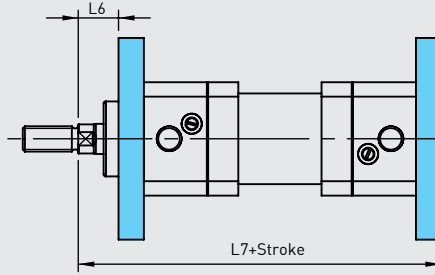

RC ROD CLEVIS

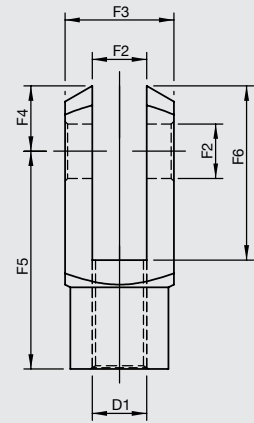

FM FOOT MOUNTING

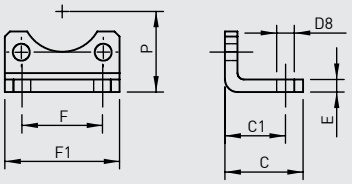

FM FOOT MOUNTING

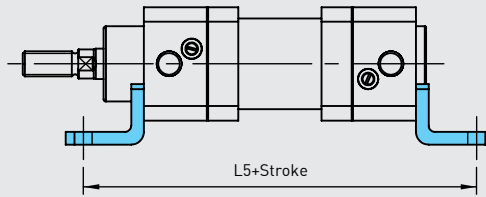

SF SWIVEL FLANGE

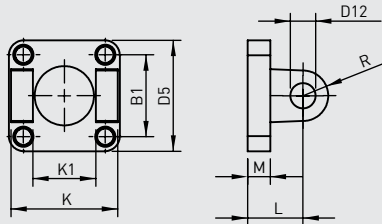

SF SWIVEL FLANGE

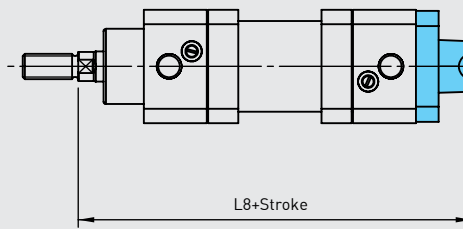

CTM CENTRAL TRUNNION MOUNTING

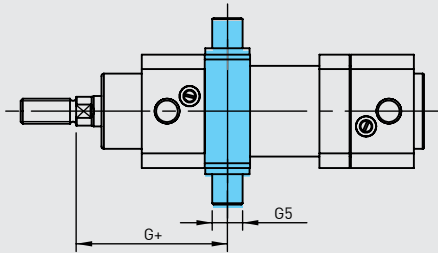

CFM CLEVIS FOOT MOUNTING

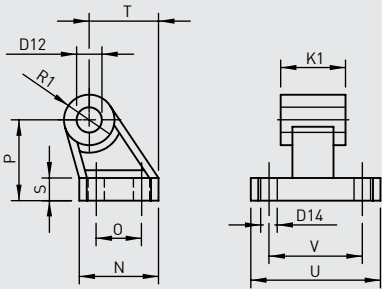

SFWCFM SWIVEL FLANGE WITH CLEVIS FOOT MOUNTING

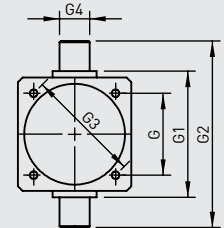
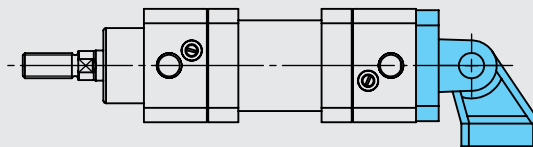

Cylinder Ø mm	B1	C	C1	D1	D3 Ø	D5	D8 Ø	D9	D10 Ø	D11	D12 Ø	D14 Ø	E	F	F1	F2 Ø	F3	F4	F5	F6	G	G1
32	32,5	32	24	M10x1.25	30	45	7	77	7	64	10	5,5	4	32	45	10	20	12	40	32	32,5	50
40	39,6	38	28	M12x1.25	35	54	9	90	9	72	12	5,5	5	36	54	12	24	14	48	38	39,6	63
50	48	42	32	M16x1.5	40	65	9	110	9	90	12	6,5	6	45	65	16	32	19	64	51	48	75
63	59,4	50	35	M16x1.5	42	80	9	125	9	100	16	6,5	6	50	80	16	32	19	64	51	59,4	90
80	70,7	60	43	M20x1.5	48	96	12	154	12	126	16	9	8	63	96	20	40	25	80	65	70,7	110
100	93,4	57	43	M20x1.5	52	126	14	186	14	150	20	9	8	75	126	20	40	25	80	65	93,4	132

Cylinder Ø mm	G2	G3	G4	G5	G+	H	K	K1	L	L5	L6	L7	L8	M	N	O	P	R	R1	S	T	U	V
32	74	46	12	21	65	10	45	26	22	142	16	130	142	8	31	18	32	10	10	8	27,5	51	38
40	95	56	16	24	69	10	52	28	25	161	20	145	160	9	35	22	36	13	11	10	30,5	54	41
50	107	68	16	28	79	12	60	32	27	170	25	155	170	11	45	30	45	16	13	12	40,5	65	50
63	130	84	20	28	87	15	70	40	35	185	25	170	190	12	50	35	50	18	15	12	44,5	67	52
80	150	100	20	33	98	18	90	50	38	210	30	190	210	14	60	40	63	18	15	14	57	86	66
100	182	132	25	38	108	18	110	60	43	220	35	205	230	15	70	50	71	23	19	15	65	96	76

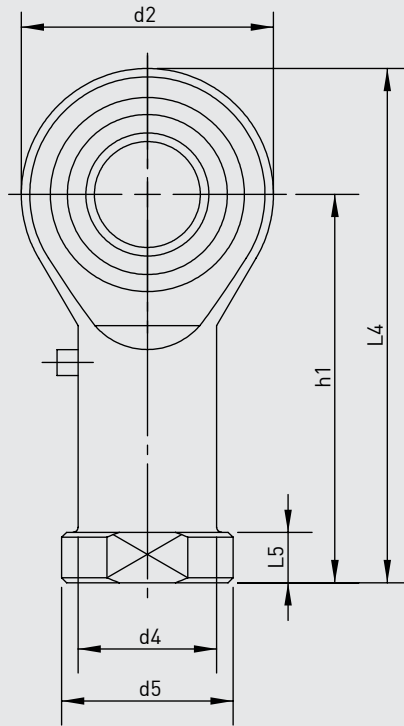
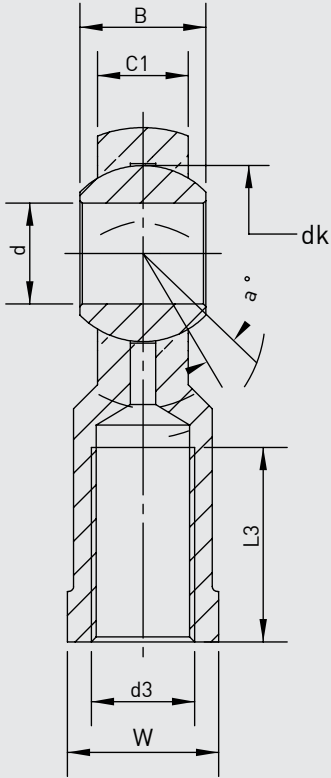

$d \leq \text{Ø} 14$

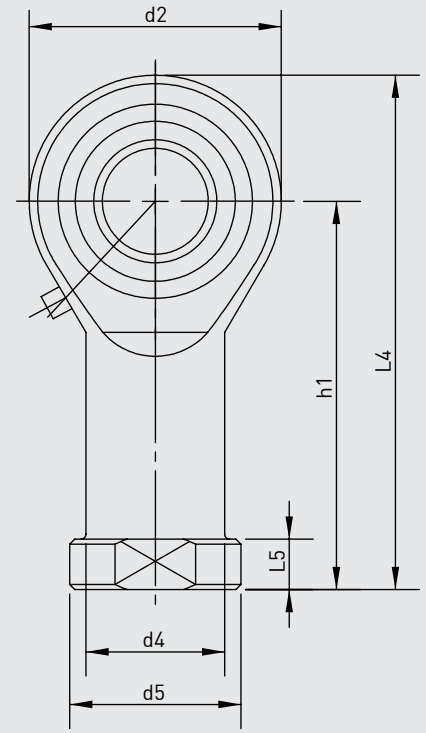

$d \geq \text{Ø} 16$



PNS SERIES
CETOP RP 43P - Ø32 - Ø100

Part No.	Dimensions (mm)													
	d	d3 6H	B	C1	w	L3 min	d2	L4	h1	L5	d4	d5	dk	a°
KMB 10-1	10	M10x1.25	14	10,5	17	20	26	56	43	6,5	15	19	19,05	13
KMB 12-1	12	M12x1.25	16	12	19	22	30	65	50	6,5	17,5	22	22,225	13
KMB 16-1	16	M16x1.5	21	15	22	28	40	84	64	8	22	27	28,575	15
KMB 20	20	M20x1.5	25	18	30	33	50	102	77	10	27,5	34	34,925	14

**CETOP RP 53P-43P
PNEUMATIC CYLINDERS
PAG SERIES Ø32 - Ø100**





PAG SERIES

CETOP RP 43P - Ø32 - Ø100

CUSHIONING CYLINDER

WITH LONG-LIVED AND HIGH PERFORMANCE THE LITTLE GIANT SINCE 20 YEARS



PAG: DOUBLE ACTING CYLINDER

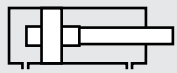

PAG-Y: DOUBLE ACTING CYLINDER WITH CUSHIONING



PAG-D: DOUBLE ACTING CYLINDER WITH DOUBLE ROD

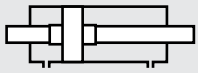

PAG-YD: DOUBLE ACTING CYLINDER WITH CUSHIONING AND DOUBLE ROD

Example of order:

PAG-Y
Product Code

040-0500
Cylinder Ø Stroke

SF RE
Cylinder Mountings

K1
Variants from Standard System

VARIANTS FROM STANDARD SYSTEM:

- R1: Stainless Steel Piston Rod (SS 304-SS 316)
- R4: Stainless Steel Nut for Piston Rod (SS 304)
- M1: Extended male Piston Rod Thread
- M2: Female Piston Rod Thread
- M3: Special Piston Rod Thread
- M4: Extended Piston Rod
- K1: Seals for Max. 150°C (Viton)
- K2: Piston Rod Seal NBR + PA
- K3: Seals NBR
- K4: Piston Rod Seal Viton

Force:

Cylinder Ø mm	Rod Ø mm	Thrust and traction forces (6 Bar)	
		Thrust Force (N)	Traction Force (N)
32 12	482	415	
40 16	754	633	
50 20	1178	990	
63 20	1870	1682	
80 25	3016	2721	
100 25	4712	4418	

Working Fluid:

Filtered and lubricated air

Operating Temperature Range:

NBR+Polyurethane (PU): (-20°C) - (+80°C)
 Viton (FKM) : (-30°C) - (+180°C)

Max. Work Pressure:

10 Bar

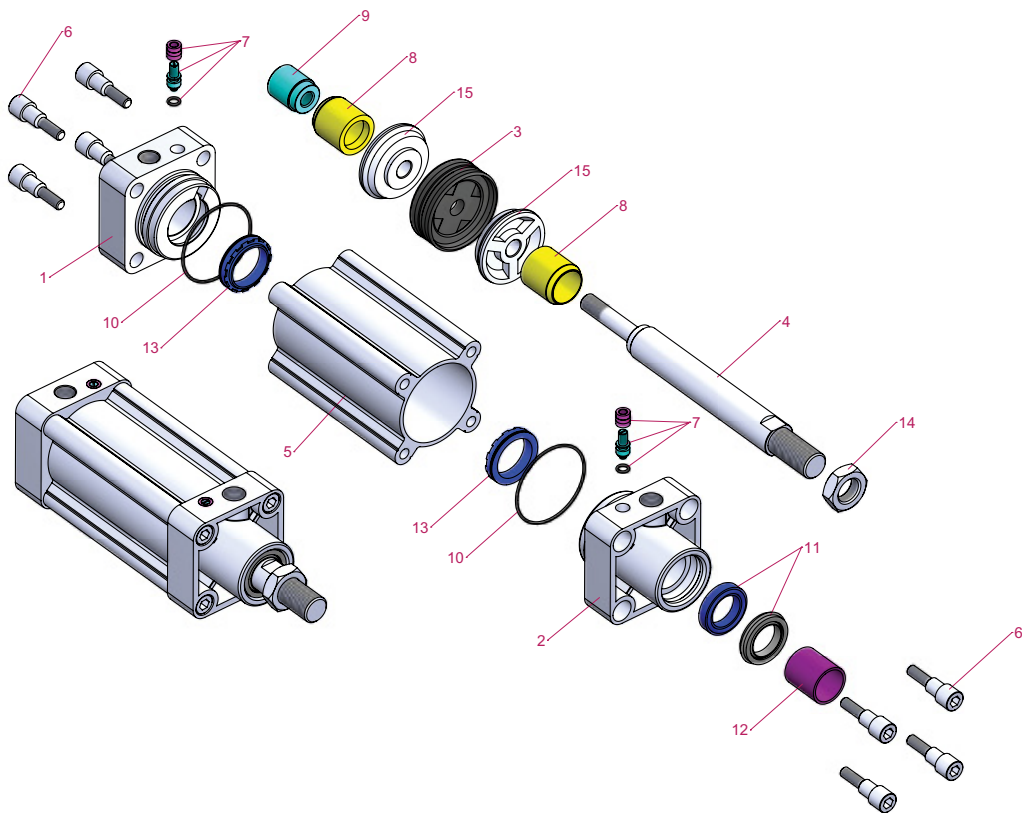
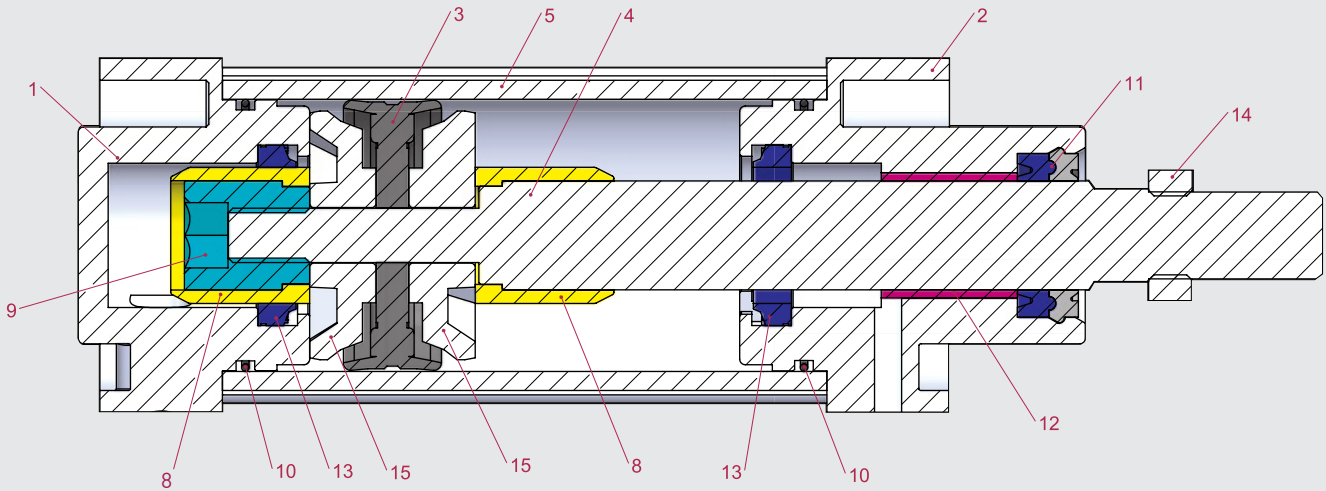

No	MATERIAL NAME	CHARACTERISTIC	PC.
1	Rear Head	Aluminium	1
2	Front Head	Aluminium	1
3	Piston Seal	NBR	1
4	Piston Rod	CK45 Hard Chrome Plated	1
5	Tube	Al Mg Si 0,5 +Eloxal Plated	1
6	Bolt	Galvanized Steel	8
7	Cushioning Screw	6082 Al. + Eloxal + AISI 303 NBR	2
8	Cushioning Plastic	Polyacetal	2
9	Cushioning Fem. Thread	Galvanized Steel	1
10	Head O-ring	NBR	2

No	MATERIAL NAME	CHARACTERISTIC	PC.
11	Rod Seal	HYTREL + PU	1
12	Guiding Bush	CSB-40	1
13	Cushioning Seal	PU	2
14	Nut	Galvanized Steel	1
15	Piston Seal Washer	Aluminium	2

Note:

Dia 32: Instead of Cushioning Plastic is used Cushioning yellow and instead of Cushioning Plastic Female Thread is used Cushioning yellow Female Thread. (Material: Brass)

The Piston Seal Washers exist only as Ø32, Ø40, Ø50

The Parts (Nr. 7,8,9,13) don't exist in the Models Without Cushioning. Fibre Nut and Washer exist instead of the Part Nr. 9

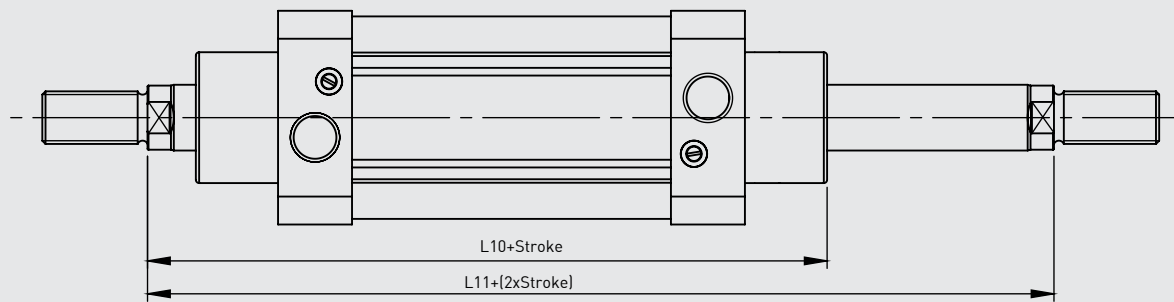
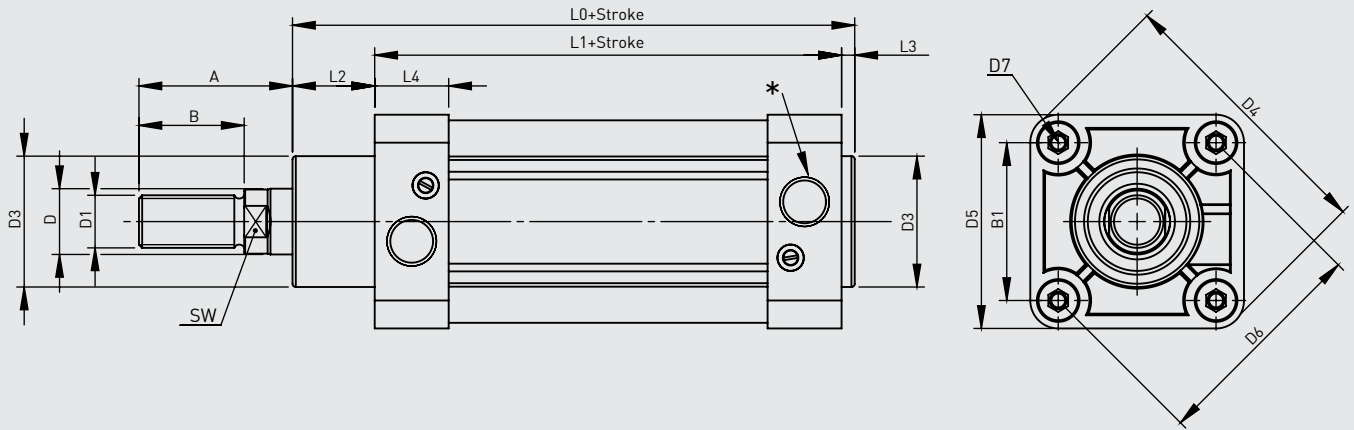

Cylinder Ø mm	A	B	B1	D Ø	D1	D3 Ø	D4	D5	D6 Ø	D7	L0	L1	L2	L3	L4	L10	L11	SW	*
32	30	20	32,5	12	M10x1.25	30	58	45	46	M5	114	94	16	4	25	120	146	10	G1/8"
40	34	24	39,6	16	M12x1.25	35	71	54	56	M5	130,5	105	20	4	23	135	165	13	G1/4"
50	44	32	48	20	M16x1.5	40	85	65	68	M6	136	106	25	4	23	143	180	17	G1/4"
63	44	32	59,4	20	M16x1.5	42	105	80	84	M6	149	115	28	4	27	155	195	17	G3/8"
80	54	40	70,7	25	M20x1.5	48	125	96	100	M8	164	124	34	4	27,5	172	220	22	G3/8"
100	53	40	93,4	25	M20x1.5	52	166	126	132	M8	181	134	40	4	31,5	187	240	22	G1/2"

FLM FLANGE MOUNTING

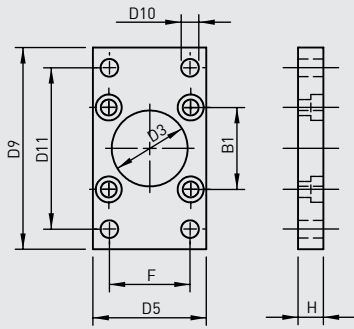

FMF FLANGE MOUNTING AT FRONT

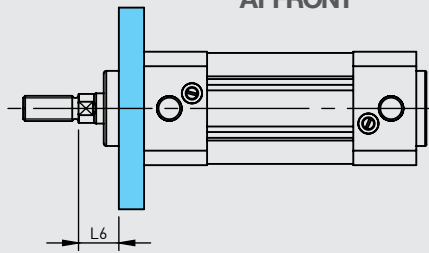

FMTR FLANGE MOUNTING AT REAR

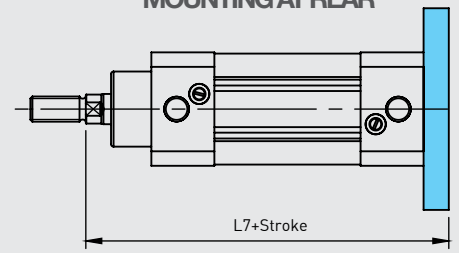

FM FOOT MOUNTING

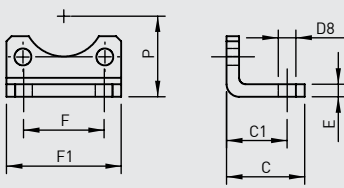

FM FOOT MOUNTING

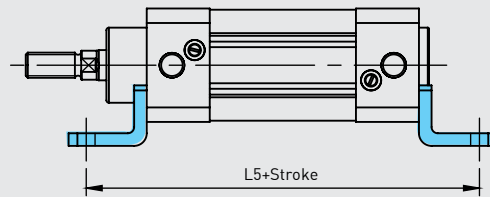

RC ROD CLEVIS

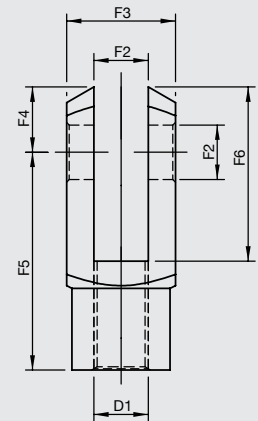

SF SWIVEL FLANGE

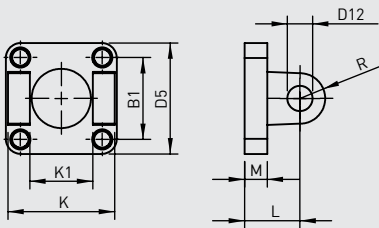

SF SWIVEL FLANGE

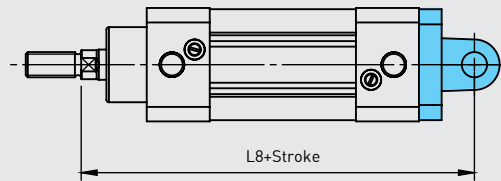

CFM CLEVIS FOOT MOUNTING

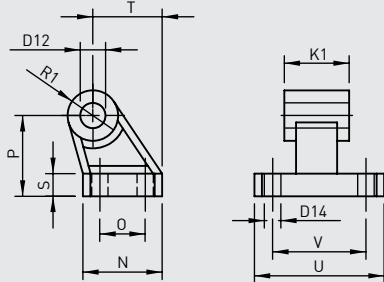

SFWCFM SWIVEL FLANGE WITH CLEVIS FOOT MOUNTING

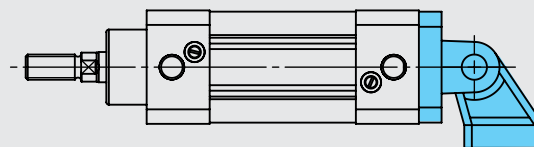

Cylinder Ø mm	B1	C	C1	D1	D3 Ø	D5	D8 Ø	D9	D10 Ø	D11	D12 Ø	D14 Ø	E	F	F1	F2 Ø	F3
32	32,5	32	24	M10x1.25	30	45	7	77	7	64	10	5,5	4	32	45	10	20
40	39,6	38	28	M12x1.25	35	54	9	90	9	72	12	5,5	5	36	54	12	24
50	48	42	32	M16x1.5	40	65	9	110	9	90	12	6,5	6	45	65	16	32
63	59,4	50	35	M16x1.5	42	80	9	125	9	100	16	6,5	6	50	80	16	32
80	70,7	60	43	M20x1.5	48	96	12	154	12	126	16	9	8	63	96	20	40
100	93,4	57	43	M20x1.5	52	126	14	186	14	150	20	9	8	75	126	20	40

Cylinder Ø mm	F4	F5	F6	H	K	K1	L	L5	L6	L7	L8	M	N	O	P	R	R1	S	T	U	V
32	12	40	32	10	45	26	22	142	16	130	142	8	31	18	32	10	10	8	27,5	51	38
40	14	48	38	10	52	28	25	161	20	145	160	9	35	22	36	13	11	10	30,5	54	41
50	19	64	51	12	60	32	27	170	25	155	170	11	45	30	45	16	13	12	40,5	65	50
63	19	64	51	15	70	40	35	185	25	170	190	12	50	35	50	18	15	12	44,5	67	52
80	25	80	65	18	90	50	38	210	30	190	210	14	60	40	63	18	15	14	57	86	66
100	25	80	65	18	110	60	43	220	35	205	230	15	70	50	71	23	19	15	65	96	76

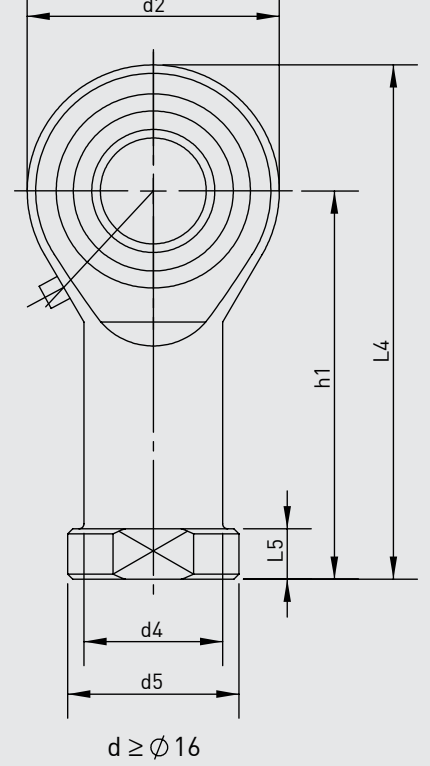
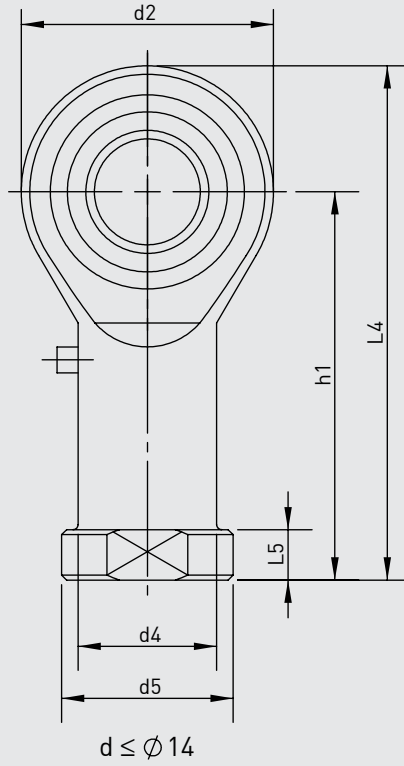
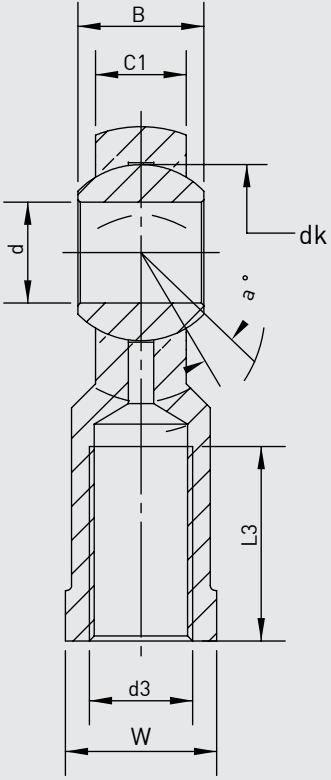

PAG SERIES
CETOP RP 43P - Ø32 - Ø100

Parça No.	Ölçüler (mm)													
	d	d3 6H	B	C1	w	L3 min	d2	L4	h1	L5	d4	d5	dk	a°
KMB 10-1	10	M10x1.25	14	10,5	17	20	26	56	43	6,5	15	19	19,05	13
KMB 12-1	12	M12x1.25	16	12	19	22	30	65	50	6,5	17,5	22	22,225	13
KMB 16-1	16	M16x1.5	21	22	22	28	40	84	64	8	22	27	28,575	15
KMB 20	20	M20x1.5	25	18	30	33	50	102	77	10	27,5	34	34,925	14

ISO 6432
PNEUMATIC CYLINDERS
PM-A SERIES Ø8 - Ø25





PM-A SERIES

ISO 6432 - Ø8 - Ø25

DOUBLE ACTING CYLINDER
WITH MAGNET

WITH STAINLESS STEEL ROD AND
TUBE, HIGHER WORKING SPEED



PM-A: DOUBLE ACTING MAGNETIC

Example of order:

<u>PM-A</u>	<u>25-050</u>	<u>SF RC</u>	<u>K1</u>
Product Code	Cylinder Ø _{Stroke}	Cylinder Mountings	Variants from Standard System

VARIANTS FROM STANDARD SYSTEM:

- R1: Stainless Steel Piston Rod (SS 304-SS 316)
- R4: Stainless Steel Nut for Piston Rod (SS 304)
- R5: Piston Rod as CK45 (Hard Chrome Plated)
- M1: Extended male Piston Rod Thread
- M2: Female Piston Rod Thread
- M3: Special Piston Rod Thread
- M4: Extended Piston Rod
- E2: Stainless Steel Cylinder Covers (SS 304-SS316)
- K1: Seals for Max. 150°C (Viton)
- K3: Seals NBR
- K4: Piston Rod Seal Viton

Force:

Cylinder Ø mm	Rod Ø mm	Thrust and traction forces (6 Bar)	
		Thrust Force (N)	Traction Force (N)
8	4	24	15
10	4	41	32
12	6	55	38
16	6	105	88
20	8	165	141
25	10	266	219

Working Fluid:

Filtered and lubricated or filtered and not lubricated air

Operating Temperature Range:

Polyurethane (PU) : (-20°C) - (+80°C)
Viton (FKM) : (-30°C) - (+180°C)

Max. Work Pressure:

10 Bar

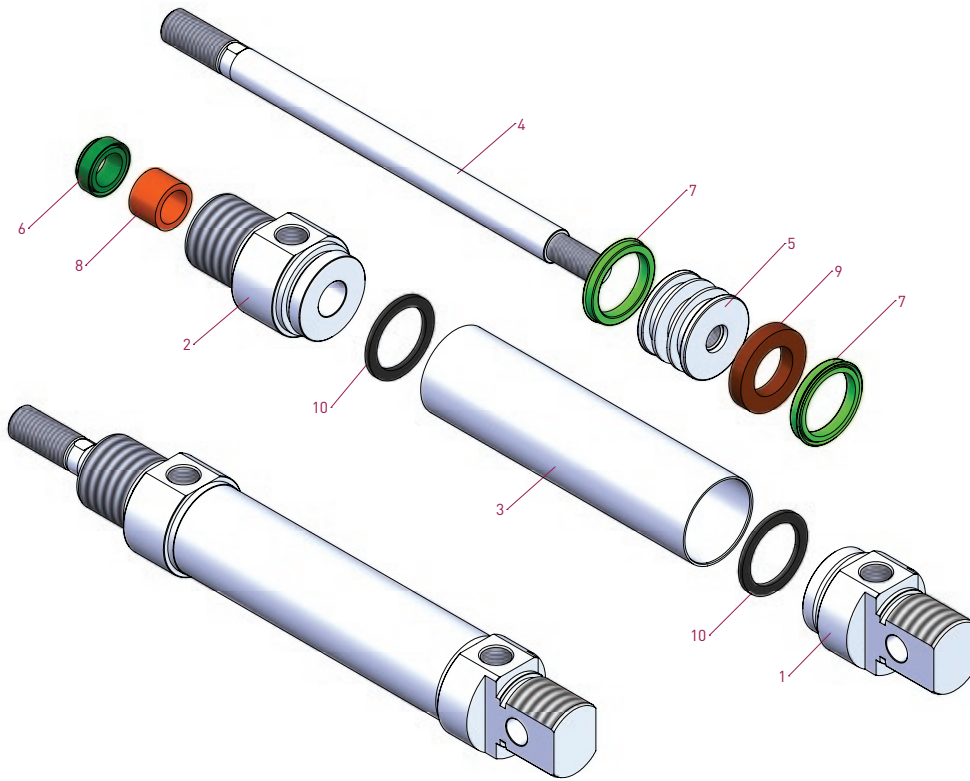
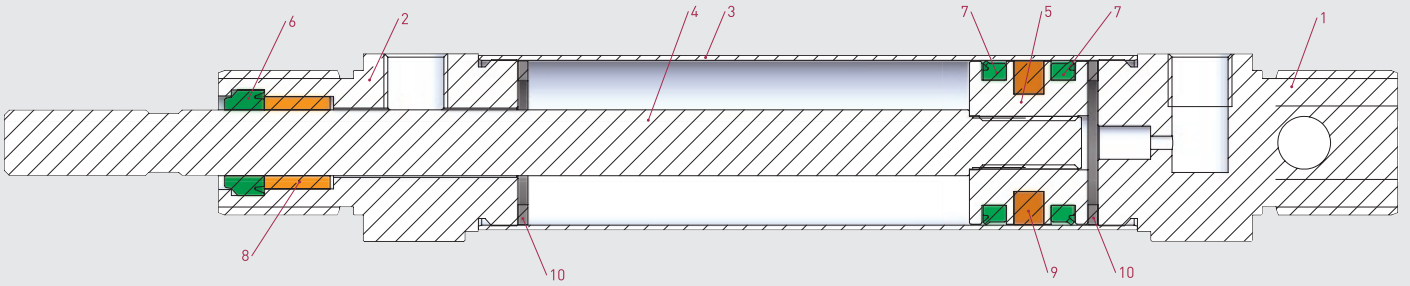

No	MATERIAL NAME	CHARACTERISTIC	PC.
1	Rear Head	Aluminium	1
2	Front Head	Aluminium	1
3	Tube	SS 304	1
4	Piston Rod	SS 303	1
5	Middle Piston	Brass	1

No	MATERIAL NAME	CHARACTERISTIC	PC.
6	Rod Seal	PU	1
7	Piston Seal	PU	2
8	Guidind Bush	Sinterized Bronze	1
9	Magnet		1
10	Buffer	NBR	2

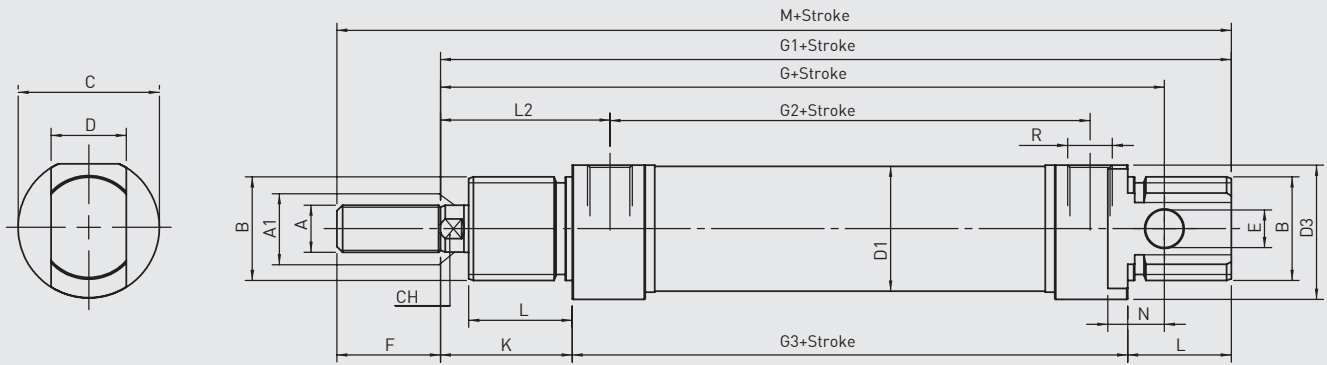

PM-A SERIES
ISO 6432 - Ø8- Ø25

Cylinder Ø mm	A	A1	B	C	D	D1	D3	E	F	G	G1	G2	G3	K	L	L2	N	CH	R	M
8	M4	4	M12x1.25	16	8	9,27	15	4	12	64	74	36	46	16	12	21	6	/	M5	86
10	M4	4	M12x1.25	16	8	11,27	15	4	12	64	74	36	46	16	12	21	6	/	M5	86
12	M6	6	M16x1.5	19	12	13,27	18	6	16	75	88	38	48	22	18	27	9	5	M5	104
16	M6	6	M16x1.5	19	12	17,27	18	6	16	82	93	44	53	22	18	27	9	5	M5	109
20	M8	8	M22x1.5	27	16	21,27	25,5	8	20	95	111	51,5	67	24	20	32	12	7	1/8" G	131
25	M10x1.25	10	M22x1.5	30	16	26,5	28,5	8	22	104	118	52	68	28	22	36	12	9	1/8" G	140

SF SWIVEL FLANGE

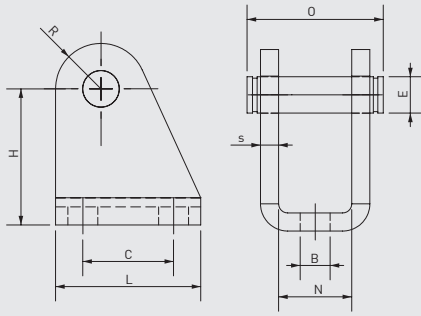

Cylinder Ø mm	B H13	E f8	C JS13	H ±0.2	L	N E9	O	R max	S ±0.2
8-10	4,5	4	12,5	24	20	8,1	17	5	2,5
12-16	5,5	6	15	27	25	12,1	23	7	3
20-25	6,6	8	20	30	32	16,1	29,5	10	4

FM FLANGE MOUNTING

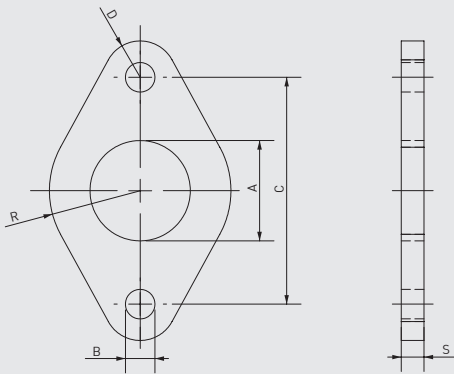

Cylinder Ø mm	A +0.3 +0.1	B H13	C JS13	R ±0.2	G ±0.2	S ±0.2
8-10	12	4,5	30	11	5	3
12-16	16	5,5	40	15	6	4
20-25	22	6,6	50	20	8	5

FM FOOT MOUNTING

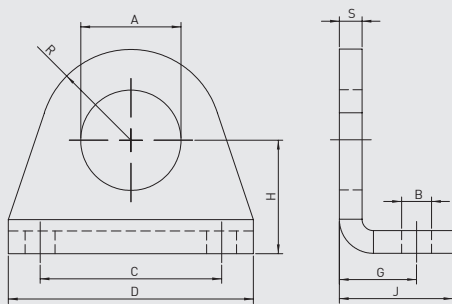

Cylinder Ø mm	A +0.2 +0.1	B H13	C JS13	D	G +0.3 0	H ±0.2	J	R max	S ±0.2
8-10	12	4,5	25	35	11	16	16	10	3
12-16	16	5,5	32	42	14	20	20	12,5	4
20-25	22	6,6	40	54	17	25	25	20	5

RC ROD CLEVIS

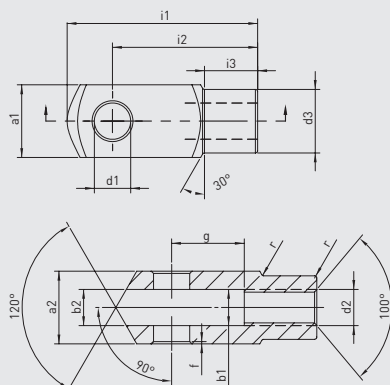

Cylinder Ø mm	d1 H9	g ±0.5	a1 h11	a2 +0.3 -0.16	b1 B13	b2	d2 6H	d3 ±0.3	f ±0.2	i1 ±0.5	i2	i3 ±0.2	r
8-10	4	8	8	8	4	4	M4x0.70	8	0,5	21	16	6	0,5
12-16	6	12	12	12	6	6	M6x1.00	10	0,5	31	24	9	0,5
20	8	16	16	16	8	8	M8x1.25	14	0,5	42	32	12	0,5
25	10	20	20	20	10	10	M10x1.25	18	0,5	52	40	15	0,5

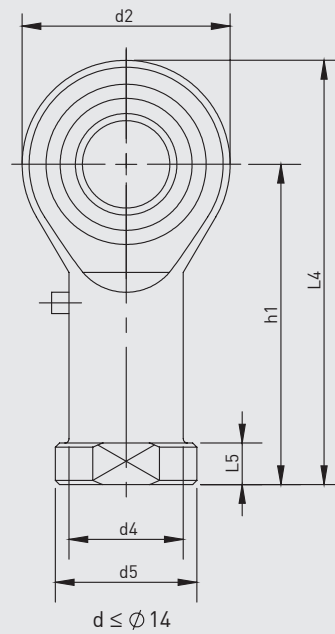
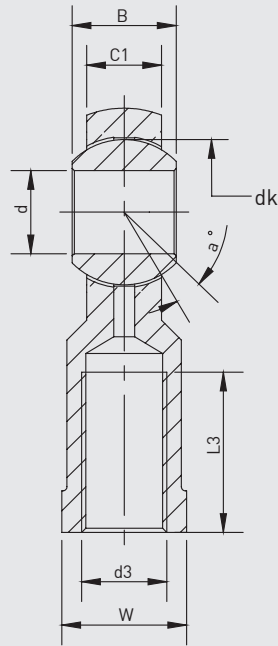

Part No.	Dimensions (mm)													
	d	d3 6H	B	C1	w	L3 min	d2	L4	h1	L5	d4	d5	dk	a°
KMB 6	6	M6x1.0	9	6,75	11	12	18	39	30	5	10	13	12,7	13
KMB 8	8	M8x1.25	12	9	14	16	22	47	36	5	12,5	16	15,875	14
KMB 10-1	10	M10x1.25	14	10,5	17	20	26	56	43	6,5	15	19	19,05	13

ISO 6432
PNEUMATIC CYLINDERS
PMY-A SERIES Ø16 - Ø25





PMY-A SERIES

ISO 6432 - Ø16 - Ø25

DOUBLE ACTING CYLINDER WITH
MAGNET AND CUSHIONING

WITH STAINLESS STEEL ROD AND
TUBE, HIGHER WORKING SPEED

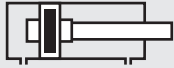

PMY-A: DOUBLE ACTING CUSHIONING
MAGNETIC

Example of order:

PMY-A
Product Code

25-050
Cylinder Ø
Stroke

SF-RE
Cylinder
Mountings

R1 K4
Variants from
Standard System

VARIANTS FROM STANDARD SYSTEM:

- R1: Stainless Steel Piston Rod (SS 304-SS 316)
- R4: Stainless Steel Nut for Piston Rod (SS 304)
- R5: Piston Rod as CK45 (Hard Chrome Plated)
- M1: Extended male Piston Rod Thread
- M2: Female Piston Rod Thread
- M3: Special Piston Rod Thread
- M4: Extended Piston Rod
- E2: Stainless Steel Cylinder Covers (SS 304-SS316)
- K1: Seals for Max. 150°C (Viton)
- K3: Seals NBR
- K4: Piston Rod Seal Viton

Force:

Cylinder Ø mm	Rod Ø mm	Thrust and traction forces (6 Bar)	
		Thrust Force (N)	Traction Force (N)
16	6	105	88
20	8	165	141
25	10	266	219

Working Fluid:

Filtered and lubricated or filtered and not lubricated air

Operating Temperature Range:

Polyurethane (PU) : (-20°C) - (+80°C)
Viton (FKM) : (-30°C) - (+180°C)

Max. Work Pressure:

10 Bar

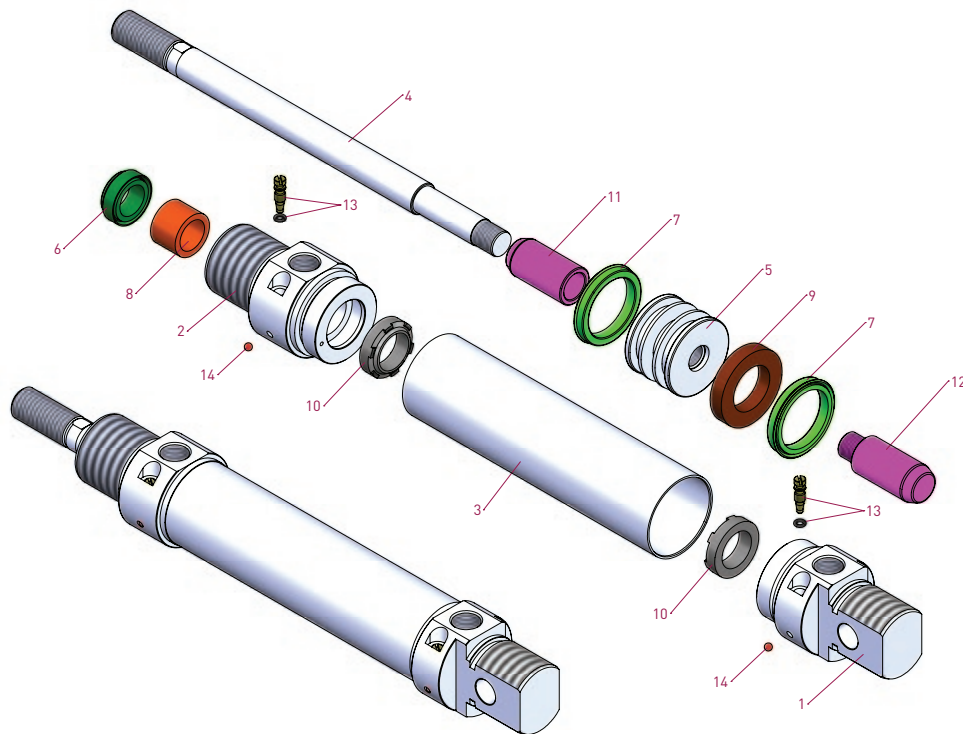
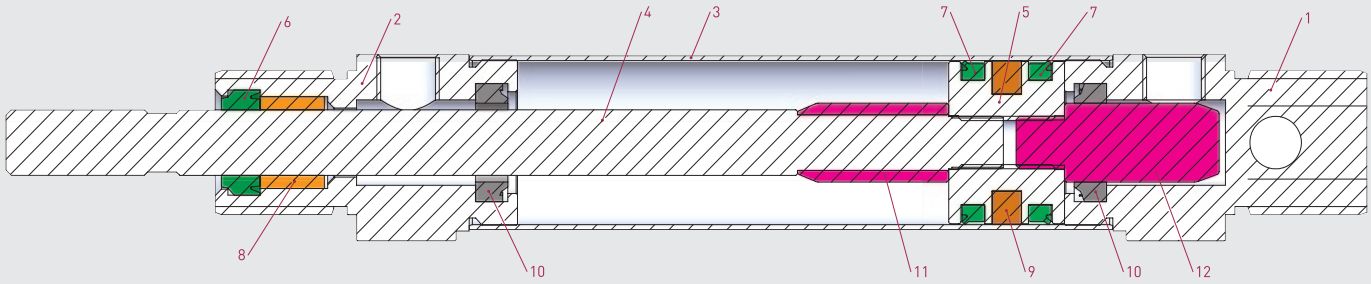

No	MATERIAL NAME	CHARACTERISTIC	PC.
1	Rear Head	Aluminium	1
2	Front Head	Aluminium	1
3	Tube	SS 304	1
4	Piston Rod	SS 303	1
5	Middle Piston	Brass	1
6	Rod Seal	PU	1
7	Piston Seal	PU	2

No	MATERIAL NAME	CHARACTERISTIC	PC.
8	Guidind Bush	Sinterized Bronze	1
9	Magnet		1
10	Cushioning Seal	NBR	2
11	Cushioning Tube	Aluminium	1
12	Cushioning Thread	Aluminium	1
13	Cushioning Screw	Aluminium	2
14	Marble		2

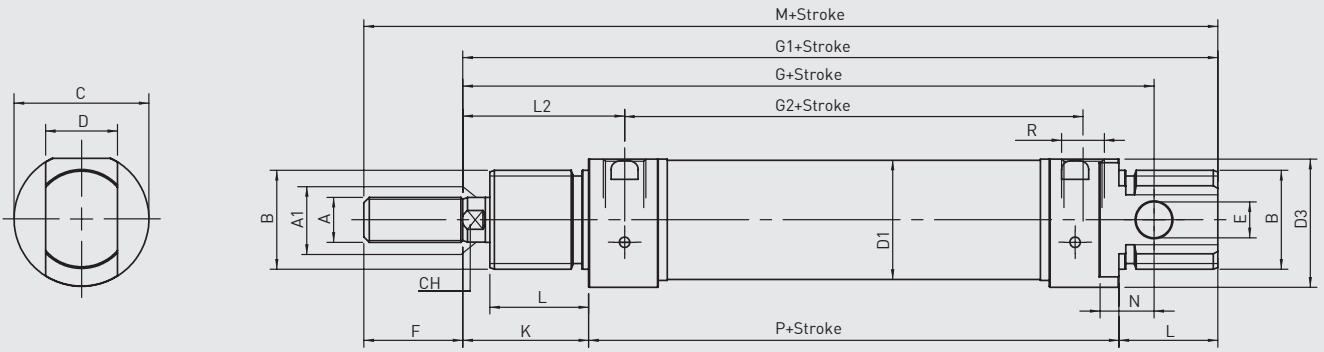

PMY-A SERIES
ISO 6432 - Ø16 - Ø25

Cylinder Ø mm	A	A1	B	C	D	D1	D3	E	F	G	G1	G2	K	L	L2	N	CH	R	P	M
16	M6	6	M16x1.5	21	12	17,27	18	6	16	82	93	43	22	17	26	9	5	M5	53	109
20	M8	8	M22x1.5	27	16	21,27	25,5	8	20	95	111	51,5	24	20	32	12	7	1/8" G	67	131
25	M10x1.25	10	M22x1.5	30	16	26,5	28,5	8	22	104	118	52	28	22	36	12	9	1/8" G	68	140

SF SWIVEL FLANGE

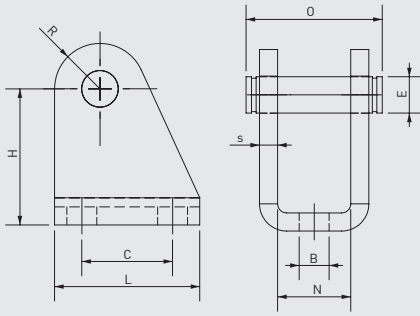

Cylinder Ø mm	B H13	E f8	C JS13	H ±0.2	L	N E9	O	R max	S ±0.2
8-10	4,5	4	12,5	24	20	8,1	17	5	2,5
12-16	5,5	6	15	27	25	12,1	23	7	3
20-25	6,6	8	20	30	32	16,1	29,5	10	4

FM FLANGE MOUNTING

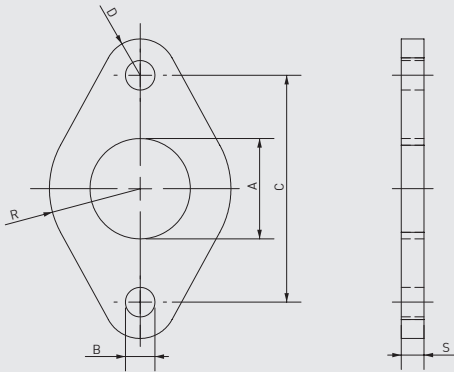

Cylinder Ø mm	A +0.3 +0.1	B H13	C JS13	R ±0.2	G ±0.2	S ±0.2
8-10	12	4,5	30	11	5	3
12-16	16	5,5	40	15	6	4
20-25	22	6,6	50	20	8	5

FM FOOT MOUNTING

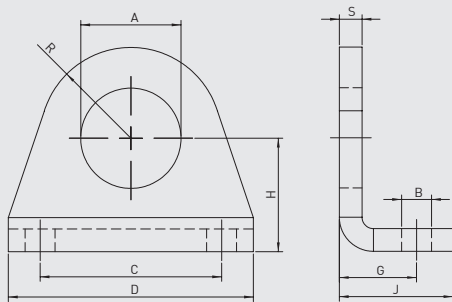

Cylinder Ø mm	A +0.2 +0.1	B H13	C JS13	D	G +0.3 0	H ±0.2	J	R max	S ±0.2
8-10	12	4,5	25	35	11	16	16	10	3
12-16	16	5,5	32	42	14	20	20	12,5	4
20-25	22	6,6	40	54	17	25	25	20	5

RC ROD CLEVIS

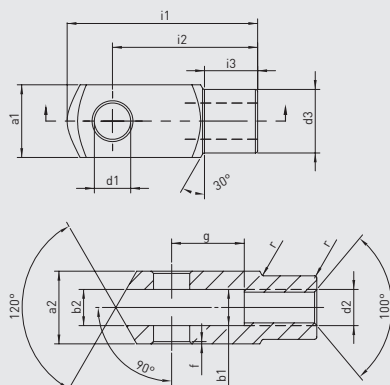

Cylinder Ø mm	d1 H9	g ±0.5	a1 h11	a2 +0.3 -0.16	b1 B13	b2	d2 6H	d3 ±0.3	f ±0.2	i1 ±0.5	i2	i3 ±0.2	r
8-10	4	8	8	8	4	4	M4x0.70	8	0,5	21	16	6	0,5
12-16	6	12	12	12	6	6	M6x1.00	10	0,5	31	24	9	0,5
20	8	16	16	16	8	8	M8x1.25	14	0,5	42	32	12	0,5
25	10	20	20	20	10	10	M10x1.25	18	0,5	52	40	15	0,5

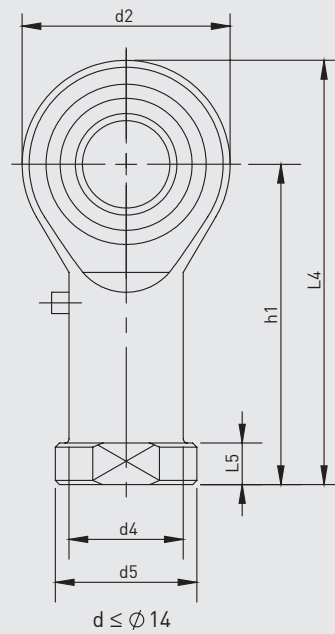
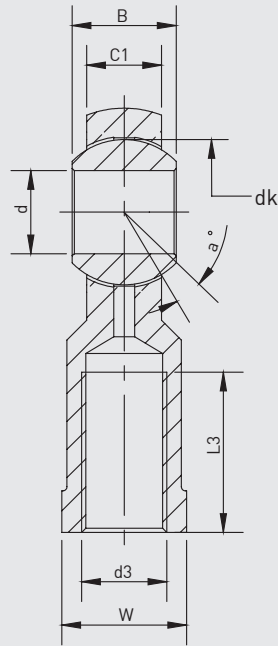

Part No.	Dimensions (mm)													
	d	d3 6H	B	C1	w	L3 min	d2	L4	h1	L5	d4	d5	dk	a°
KMB 6	6	M6x1.0	9	6,75	11	12	18	39	30	5	10	13	12,7	13
KMB 8	8	M8x1.25	12	9	14	16	22	47	36	5	12,5	16	15,875	14
KMB 10-1	10	M10x1.25	14	10,5	17	20	26	56	43	6,5	15	19	19,05	13

ISO 6432
PNEUMATIC CYLINDERS
PMD-A SERIES Ø16 - Ø25





PMD-A SERIES

ISO 6432 - Ø16 - Ø25

DOUBLE ACTING CYLINDER WITH
DOUBLE ROD
AND MAGNET

DOUBLE DIRECTION RUN AND
STROK ADJUSTMENT IS POSSIBLE



PMD-A: DOUBLE ACTING MAGNETIC
AND DOUBLE ROD

Example of order:

PMD-A
Product Code

25-050
Cylinder Ø
Stroke

FM
Cylinder
Mountings

M1
Variants from
Standard System

VARIANTS FROM STANDARD SYSTEM:

- R1: Stainless Steel Piston Rod (SS 304-SS 316)
- R4: Stainless Steel Nut for Piston Rod (SS 304)
- R5: Piston Rod as CK45 (Hard Chrome Plated)
- M1: Extended male Piston Rod Thread
- M2: Female Piston Rod Thread
- M3: Special Piston Rod Thread
- M4: Extended Piston Rod
- E2: Stainless Steel Cylinder Covers (SS 304-SS316)
- K1: Seals for Max. 150°C (Viton)
- K3: Seals NBR
- K4: Piston Rod Seal Viton

Force:

Cylinder Ø mm	Rod Ø mm	Thrust and traction forces (6 Bar)	
		Thrust Force (N)	Traction Force (N)
16	6	88	88
20	8	141	141
25	10	219	219

Working Fluid:

Filtered and lubricated or filtered and not lubricated air

Operating Temperature Range:

Polyurethane (PU) : (-20°C) - (+80°C)

Viton (FKM) : (-30°C) - (+180°C)

Max. Work Pressure:

10 Bar

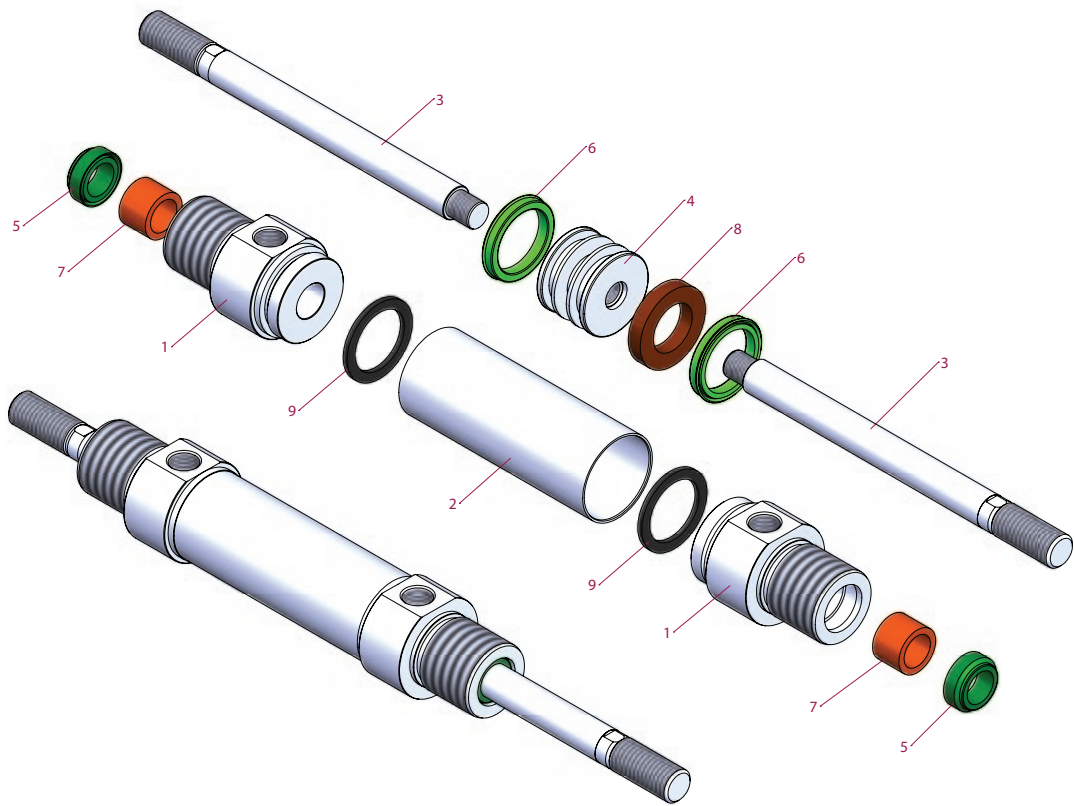
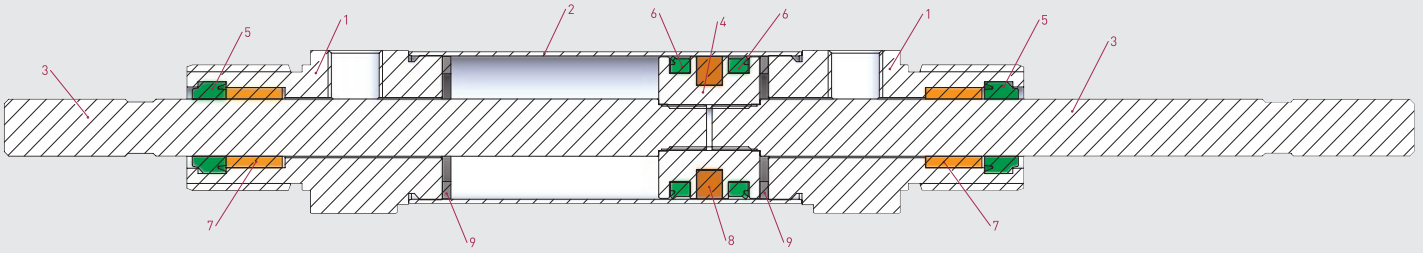

No	MATERIAL NAME	CHARACTERISTIC	PC.
1	Head	Aluminium	2
2	Tube	SS 304	1
3	Piston Rod	SS 303	2
4	Middle Piston	Brass	1
5	Rod Seal	PU	2

No	MATERIAL NAME	CHARACTERISTIC	PC.
6	Piston Seal	PU	2
7	Guidind Bush	Sinterized Bronze	2
8	Magnet		1
9	Buffer	NBR	2

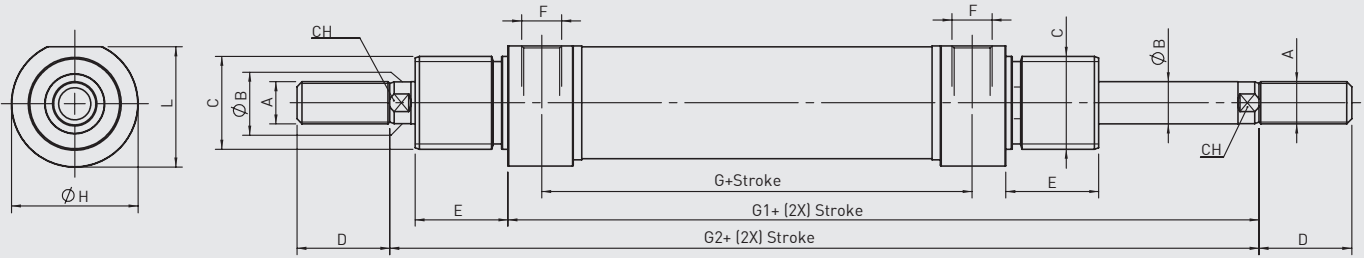

PMD-A SERIES
ISO 6432 - Ø16 - Ø25

Cylinder Ø mm	A	ØB	C	D	E	F	G	G1	G2	ØH	L	CH
16	M6	6	M16x1.5	16	18	M5	43	75	97	19	18	5
20	M8	8	M22x1.5	20	20	1/8" G	51,5	91	115	27	25,5	7
25	M10x1.25	10	M22x1.5	22	22	1/8" G	52	96	124	30	28,5	9

SF SWIVEL FLANGE

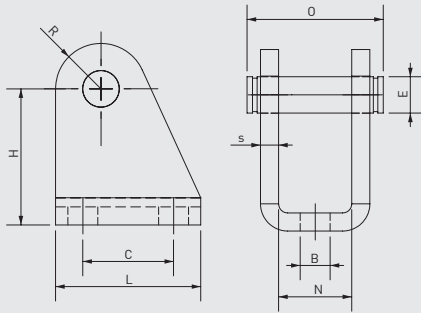

Cylinder Ø mm	B H13	E f8	C JS13	H ±0.2	L	N E9	O	R max	S ±0.2
8-10	4,5	4	12,5	24	20	8,1	17	5	2,5
12-16	5,5	6	15	27	25	12,1	23	7	3
20-25	6,6	8	20	30	32	16,1	29,5	10	4

FM FLANGE MOUNTING

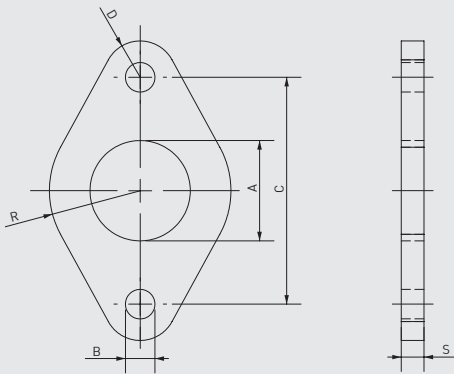

Cylinder Ø mm	A +0.3 +0.1	B H13	C JS13	R ±0.2	G ±0.2	S ±0.2
8-10	12	4,5	30	11	5	3
12-16	16	5,5	40	15	6	4
20-25	22	6,6	50	20	8	5

FM FOOT MOUNTING

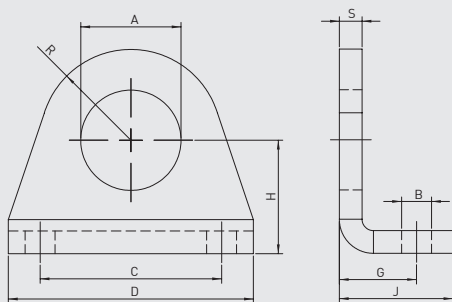

Cylinder Ø mm	A +0.2 +0.1	B H13	C JS13	D	G +0.3 0	H ±0.2	J	R max	S ±0.2
8-10	12	4,5	25	35	11	16	16	10	3
12-16	16	5,5	32	42	14	20	20	12,5	4
20-25	22	6,6	40	54	17	25	25	20	5

RC ROD CLEVIS

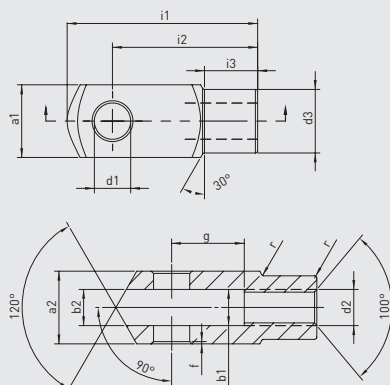

Cylinder Ø mm	d1 H9	g ±0.5	a1 h11	a2 +0.3 -0.16	b1 B13	b2	d2 6H	d3 ±0.3	f ±0.2	i1 ±0.5	i2	i3 ±0.2	r
8-10	4	8	8	8	4	4	M4x0.70	8	0,5	21	16	6	0,5
12-16	6	12	12	12	6	6	M6x1.00	10	0,5	31	24	9	0,5
20	8	16	16	16	8	8	M8x1.25	14	0,5	42	32	12	0,5
25	10	20	20	20	10	10	M10x1.25	18	0,5	52	40	15	0,5

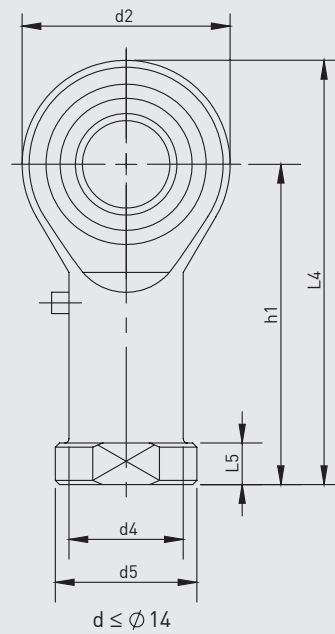
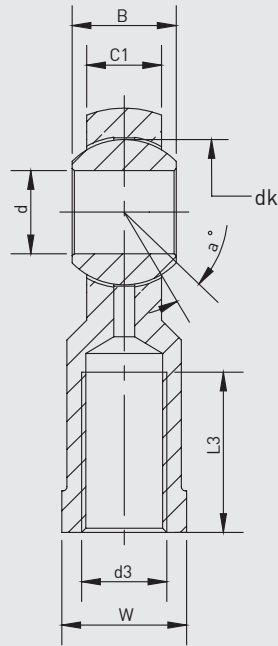

Part No.	Dimensions (mm)													
	d	d3 6H	B	C1	w	L3 min	d2	L4	h1	L5	d4	d5	dk	a°
KMB 6	6	M6x1.0	9	6,75	11	12	18	39	30	5	10	13	12,7	13
KMB 8	8	M8x1.25	12	9	14	16	22	47	36	5	12,5	16	15,875	14
KMB 10-1	10	M10x1.25	14	10,5	17	20	26	56	43	6,5	15	19	19,05	13

ISO 6432
PNEUMATIC CYLINDERS
PMS-A SERIES Ø10 - Ø25





PMS-A SERIES

ISO 6432 - Ø10 - Ø25

MAGNETIC CYLINDER
WITH FRONT SPRING

PROVIDES MINIMUM AIR
CONSUMPTION AND EQUIPMENT
COSTS



PMS-A: SINGLE ACTING (SPRING ON FRONT) MAGNETIC

Example of order:

PMS-A
Product Code

25-050
Cylinder Ø
Stroke

FM
Cylinder
Mountings

M4
Variants from
Standard System

VARIANTS FROM STANDARD SYSTEM:

- R1: Stainless Steel Piston Rod (SS 304-SS 316)
- R4: Stainless Steel Nut for Piston Rod (SS 304)
- R5: Piston Rod as CK45 (Hard Chrome Plated)
- M1: Extended male Piston Rod Thread
- M2: Female Piston Rod Thread
- M3: Special Piston Rod Thread
- M4: Extended Piston Rod
- E2: Stainless Steel Cylinder Covers (SS 304-SS316)
- K1: Seals for Max. 150°C (Viton)
- K3: Seals NBR
- K4: Piston Rod Seal Viton

Force:

Cylinder Ø mm	Rod Ø mm	Thrust Force (N)	Thrust and traction forces (6 Bar)					
			Traction Force (N)					
			Stroke 10		Stroke 25		Stroke 50	
		F1	F2	F1	F2	F1	F2	
10	4	36	4,5	5,2	3,9	5,2	2,5	5,2
12	6	49	5,7	6	5,1	6	4,1	6
16	6	87,5	15	17,5	11,5	17,5	5,3	17,5
20	8	141,5	21,3	23,5	18	23,5	12,5	23,5
25	10	246,5	18,2	19,5	16,2	19,5	12,9	19,5

Working Fluid:

Filtered and lubricated or filtered and not lubricated air

Operating Temperature Range:

Polyurethane (PU) : (-20°C) - (+80°C)
Viton (FKM) : (-30°C) - (+180°C)

Max. Work Pressure:

10 Bar

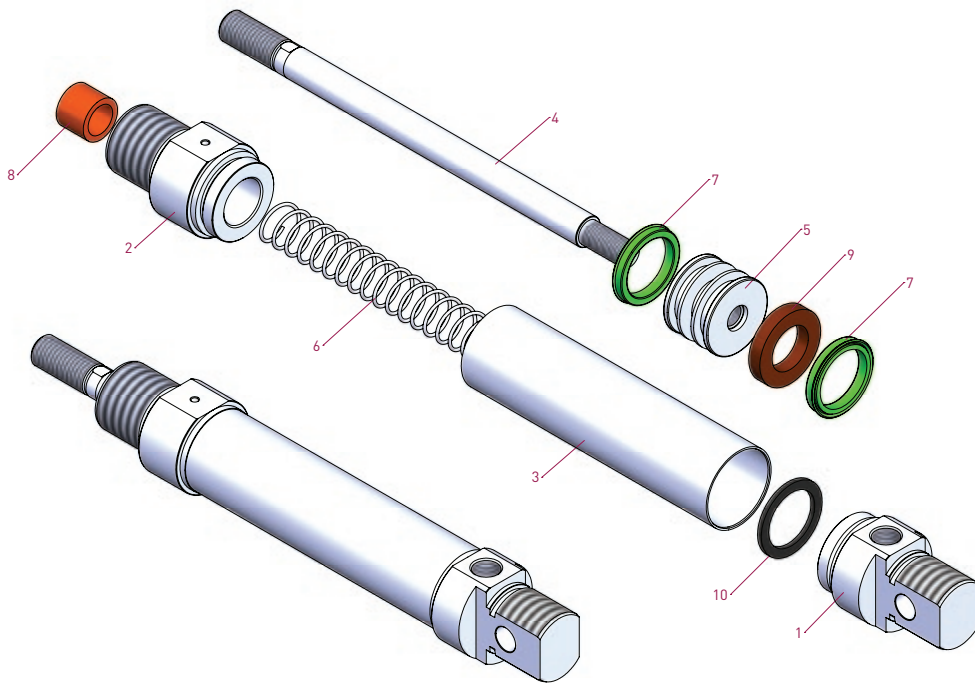
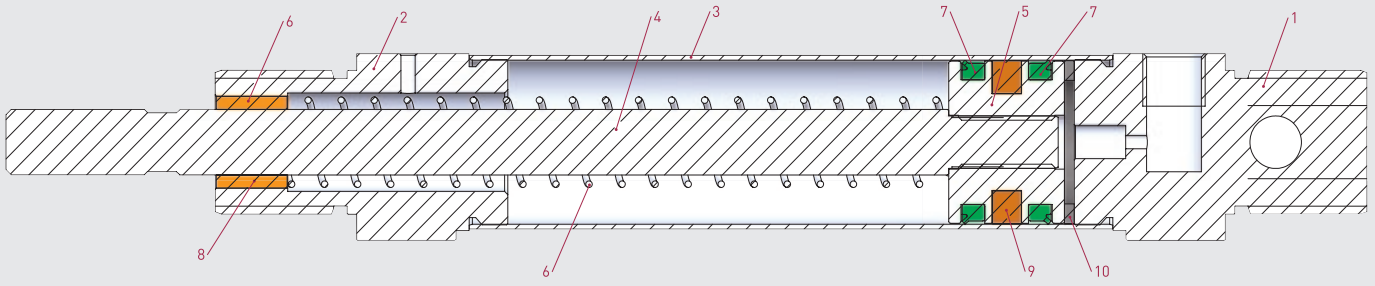

No	MATERIAL NAME	CHARACTERISTIC	PC.
1	Rear Head	Aluminium	1
2	Front Head	Aluminium	1
3	Tube	SS 304	1
4	Piston Rod	SS 303	1
5	Middle Piston	Brass	1

No	MATERIAL NAME	CHARACTERISTIC	PC.
6	Spring	Galvanized Steel	1
7	Piston Seal	PU	2
8	Guiding Bush	Sinterized Bronze	1
9	Magnet		1
10	Buffer	NBR	1

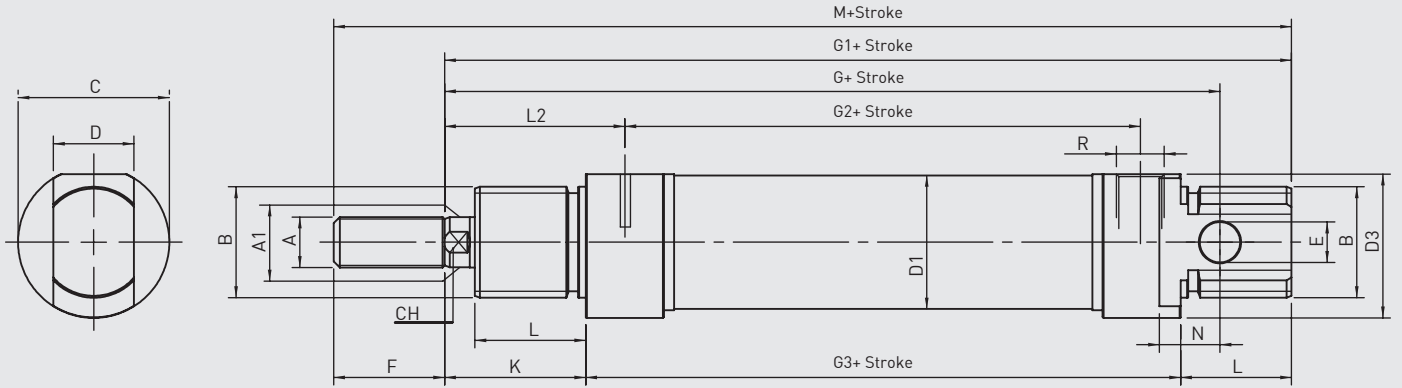

PMS-A SERIES
ISO 6432 - Ø10 - Ø25

Cylinder Ø mm	A	A1	B	C	D	D1	D3	E	F	G	G1	G2	G3	K	L	L2	N	CH	R	M
10	M4	4	M12x1.25	16	8	11,27	15	4	12	64	74	36	46	16	12	21	6	/	M5	86
12	M6	6	M16x1.5	19	12	13,27	18	6	16	75	88	38	48	22	18	27	9	5	M5	104
16	M6	6	M16x1.5	19	12	17,27	18	6	16	82	93	43	53	22	18	27	9	5	M5	109
20	M8	8	M22x1.5	27	16	21,27	25,5	8	20	95	111	51,5	67	24	20	32	12	7	1/8" G	131
25	M10x1.25	10	M22x1.5	30	16	26,5	28,5	8	22	104	118	52	68	28	22	36	12	9	1/8" G	140

SF SWIVEL FLANGE

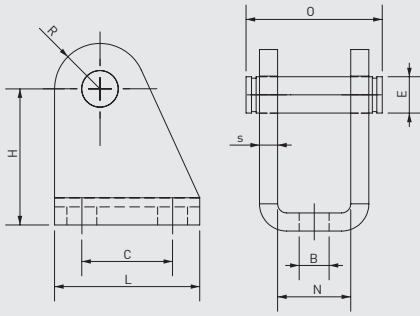

Cylinder Ø mm	B H13	E f8	C JS13	H ±0.2	L	N E9	O	R max	S ±0.2
8-10	4,5	4	12,5	24	20	8,1	17	5	2,5
12-16	5,5	6	15	27	25	12,1	23	7	3
20-25	6,6	8	20	30	32	16,1	29,5	10	4

FM FLANGE MOUNTING

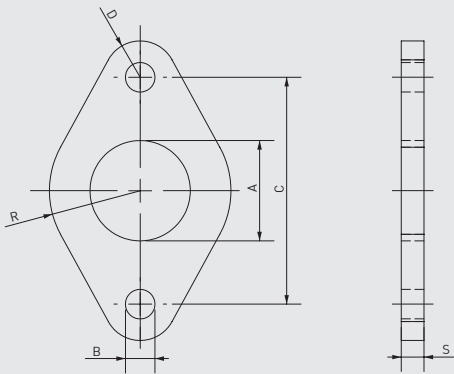

Cylinder Ø mm	A +0.3 +0.1	B H13	C JS13	R ±0.2	G ±0.2	S ±0.2
8-10	12	4,5	30	11	5	3
12-16	16	5,5	40	15	6	4
20-25	22	6,6	50	20	8	5

FM FOOT MOUNTING

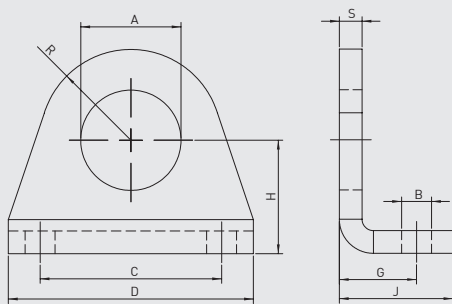

Cylinder Ø mm	A +0.2 +0.1	B H13	C JS13	D	G +0.3 0	H ±0.2	J	R max	S ±0.2
8-10	12	4,5	25	35	11	16	16	10	3
12-16	16	5,5	32	42	14	20	20	12,5	4
20-25	22	6,6	40	54	17	25	25	20	5

RC ROD CLEVIS

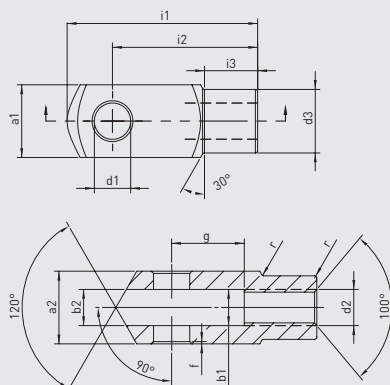

Cylinder Ø mm	d1 H9	g ±0.5	a1 h11	a2 +0.3 -0.16	b1 B13	b2	d2 6H	d3 ±0.3	f ±0.2	i1 ±0.5	i2	i3 ±0.2	r
8-10	4	8	8	8	4	4	M4x0.70	8	0,5	21	16	6	0,5
12-16	6	12	12	12	6	6	M6x1.00	10	0,5	31	24	9	0,5
20	8	16	16	16	8	8	M8x1.25	14	0,5	42	32	12	0,5
25	10	20	20	20	10	10	M10x1.25	18	0,5	52	40	15	0,5

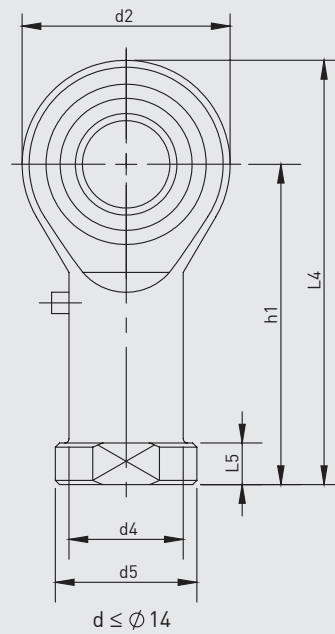
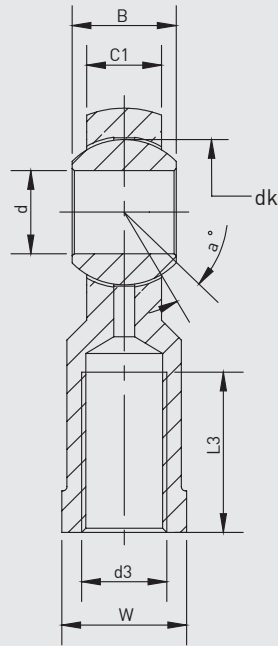

Part No.	Dimensions (mm)													
	d	d3 6H	B	C1	w	L3 min	d2	L4	h1	L5	d4	d5	dk	a°
KMB 6	6	M6x1.0	9	6,75	11	12	18	39	30	5	10	13	12,7	13
KMB 8	8	M8x1.25	12	9	14	16	22	47	36	5	12,5	16	15,875	14
KMB 10-1	10	M10x1.25	14	10,5	17	20	26	56	43	6,5	15	19	19,05	13

ISO 6432
PNEUMATIC CYLINDERS
PME-A SERIES Ø16 - Ø25





PME-A SERIES

ISO 6432 - Ø16 - Ø25

MAGNETIC CYLINDER
WITH REAR SPRING

PROVIDES MINIMUM AIR
CONSUMPTION AND EQUIPMENT
COSTS



**PME-A: SINGLE ACTING (SPRING ON
BACK) MAGNETIC**

Example of order:

PME-A
Product Code

25-050
Cylinder Ø
Stroke

FLM
Cylinder
Mountings

M2
Variants from
Standard System

VARIANTS FROM STANDARD SYSTEM:

R1: Stainless Steel Piston Rod (SS 304-SS 316)

R4: Stainless Steel Nut for Piston Rod (SS 304)

R5: Piston Rod as CK45 (Hard Chrome Plated)

M1: Extended male Piston Rod Thread

M2: Female Piston Rod Thread

M3: Special Piston Rod Thread

M4: Extended Piston Rod

E2: Stainless Steel Cylinder Covers (SS 304-SS316)

K1: Seals for Max. 150°C (Viton)

K3: Seals NBR

K4: Piston Rod Seal Viton

Force:

Cylinder Ø mm	Rod Ø mm	Thrust Force (N)	Thrust and traction forces (6 Bar)					
			Traction Force (N)					
			Stroke 10		Stroke 25		Stroke 50	
		F1	F2	F1	F2	F1	F2	
16	6	83.5	19.7	21.5	17	21.5	12.5	21.5
20	8	141.5	21.7	23.5	18	23.5	13.5	23.5
25	10	234.5	29.7	31.5	26.3	31.5	20.7	31.5

Working Fluid:

Filtered and lubricated or filtered and not lubricated air

Operating Temperature Range:

Polyurethane (PU) : (-20°C) - (+80°C)

Viton (FKM) : (-30°C) - (+180°C)

Max. Work Pressure:

10 Bar

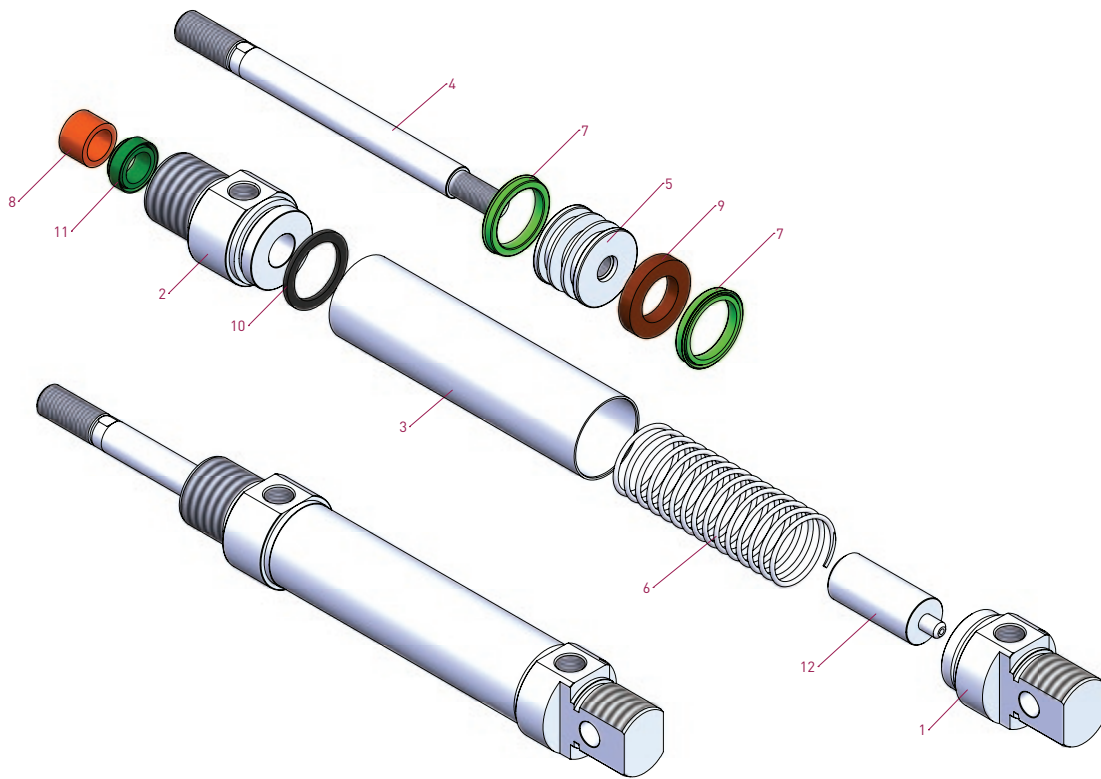
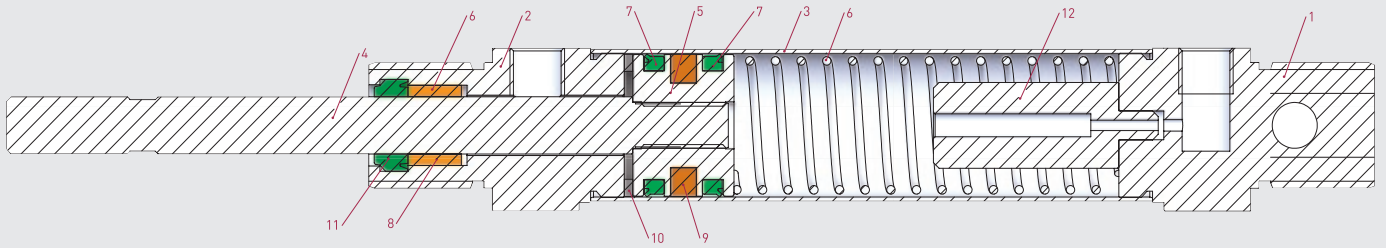

No	MATERIAL NAME	CHARACTERISTIC	PC.
1	Rear Head	Aluminium	1
2	Front Head	Aluminium	1
3	Tube	SS 304	1
4	Piston Rod	SS 303	1
5	Middle Piston	Brass	1
6	Spring	Galvanized Steel	1

No	MATERIAL NAME	CHARACTERISTIC	PC.
7	Piston Seal	PU	2
8	Guidind Bush	Sinterized Bronze	1
9	Magnet		1
10	Buffer	NBR	1
11	Rod Seal	PU	1
12	Spring Rod	Aluminium	1

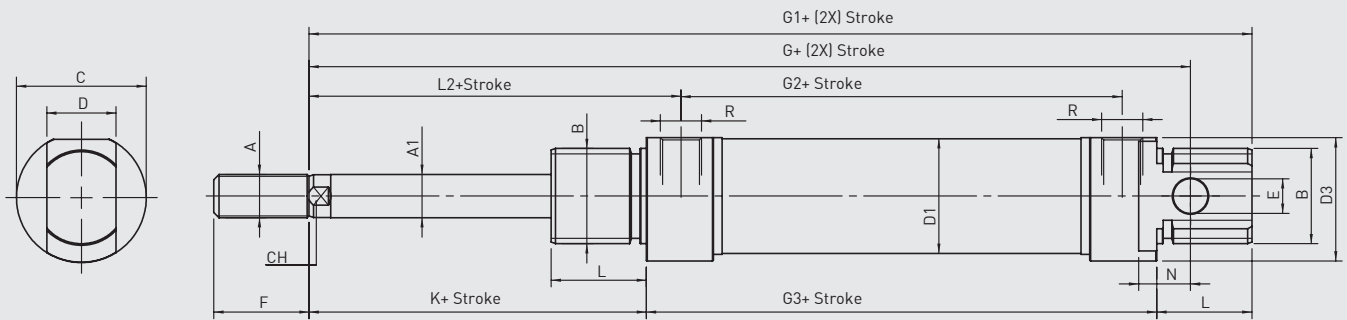

PME-A SERIES
ISO 6432 - Ø16 - Ø25

Cylinder Ø mm	A	A1	B	C	D	D1	D3	E	F	G	G1	G2	G3	K	L	L2	N	CH	R
16	M6	6	M16x1.5	19	12	17,27	18	6	16	113	124	73,5	82	22	18	27	9	5	M5
20	M8	8	M22x1.5	27	16	21,27	25,5	8	20	128	144	84,5	98,5	24	20	32	12	7	1/8" G
25	M10x1.25	10	M22x1.5	30	16	26,5	28,5	8	22	137	151	85	99,5	28	22	36	12	9	1/8" G

SF SWIVEL FLANGE

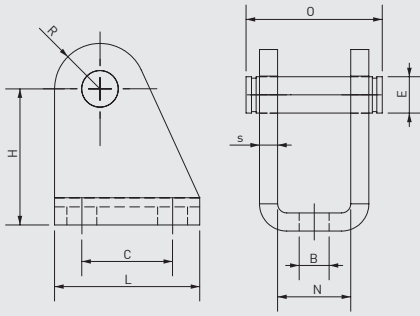

Cylinder Ø mm	B H13	E f8	C JS13	H ±0.2	L	N E9	O	R max	S ±0.2
8-10	4,5	4	12,5	24	20	8,1	17	5	2,5
12-16	5,5	6	15	27	25	12,1	23	7	3
20-25	6,6	8	20	30	32	16,1	29,5	10	4

FM FLANGE MOUNTING

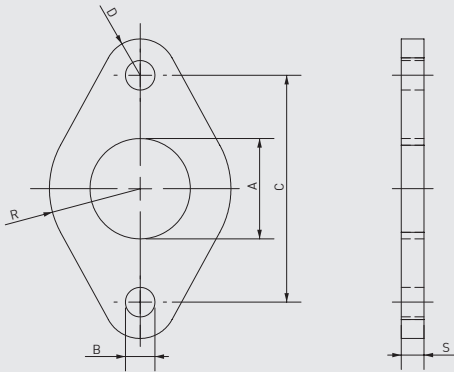

Cylinder Ø mm	A +0.3 +0.1	B H13	C JS13	R ±0.2	G ±0.2	S ±0.2
8-10	12	4,5	30	11	5	3
12-16	16	5,5	40	15	6	4
20-25	22	6,6	50	20	8	5

FM FOOT MOUNTING

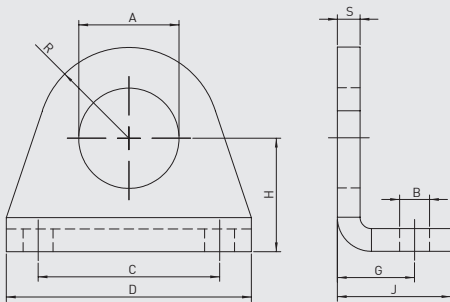

Cylinder Ø mm	A +0.2 +0.1	B H13	C JS13	D	G +0.3 0	H ±0.2	J	R max	S ±0.2
8-10	12	4,5	25	35	11	16	16	10	3
12-16	16	5,5	32	42	14	20	20	12,5	4
20-25	22	6,6	40	54	17	25	25	20	5

RC ROD CLEVIS

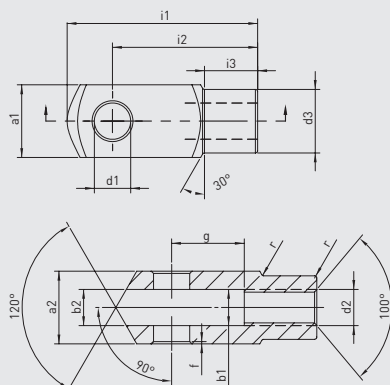

Cylinder Ø mm	d1 H9	g ±0.5	a1 h11	a2 +0.3 -0.16	b1 B13	b2	d2 6H	d3 ±0.3	f ±0.2	i1 ±0.5	i2	i3 ±0.2	r
8-10	4	8	8	8	4	4	M4x0.70	8	0,5	21	16	6	0,5
12-16	6	12	12	12	6	6	M6x1.00	10	0,5	31	24	9	0,5
20	8	16	16	16	8	8	M8x1.25	14	0,5	42	32	12	0,5
25	10	20	20	20	10	10	M10x1.25	18	0,5	52	40	15	0,5

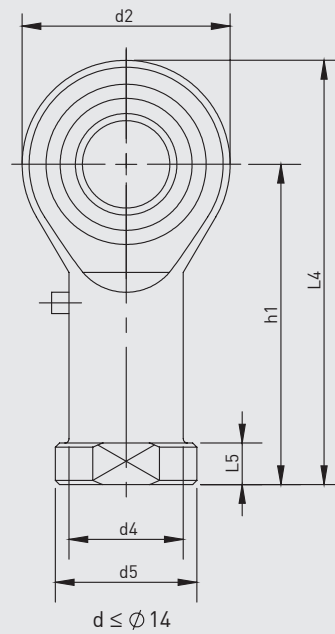
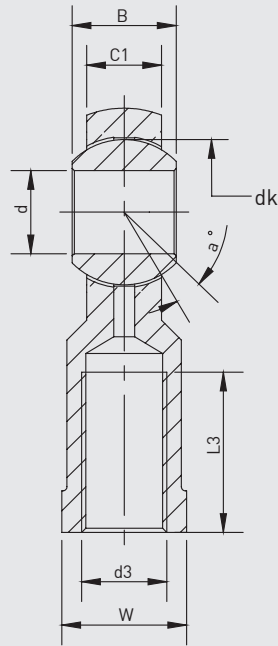

Part No.	Dimensions (mm)													
	d	d3 6H	B	C1	w	L3 min	d2	L4	h1	L5	d4	d5	dk	a°
KMB 6	6	M6x1.0	9	6,75	11	12	18	39	30	5	10	13	12,7	13
KMB 8	8	M8x1.25	12	9	14	16	22	47	36	5	12,5	16	15,875	14
KMB 10-1	10	M10x1.25	14	10,5	17	20	26	56	43	6,5	15	19	19,05	13

ISO 6432
PNEUMATIC CYLINDERS
PMDY-A SERIES Ø16 - Ø25





PMDY-A SERIES

ISO 6432 - Ø16 - Ø25

DOUBLE ACTING, DOUBLE ROD
CYLINDER WITH CUSHIONING AND
MAGNET

DOUBLE DIRECTION RUN AND
STROK ADJUSTMENT IS POSSIBLE

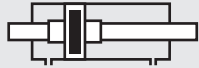

PMDY-A: DOUBLE ACTING
CUSHIONING MAGNETIC AND
DOUBLE ROD

Example of order:

PMDY-A
Product Code

25-050
Cylinder Ø
Stroke

FM
Cylinder
Mountings

M1-M4
Variants from
Standard System

VARIANTS FROM STANDARD SYSTEM:

- R1: Stainless Steel Piston Rod (SS 304-SS 316)
- R4: Stainless Steel Nut for Piston Rod (SS 304)
- R5: Piston Rod as CK45 (Hard Chrome Plated)
- M1: Extended male Piston Rod Thread
- M2: Female Piston Rod Thread
- M3: Special Piston Rod Thread
- M4: Extended Piston Rod
- E2: Stainless Steel Cylinder Covers (SS 304-SS316)
- K1: Seals for Max. 150°C (Viton)
- K3: Seals NBR
- K4: Piston Rod Seal Viton

Force:

Cylinder Ø mm	Rod Ø mm	Thrust and traction forces (6 Bar)	
		Thrust Force (N)	Traction Force (N)
16	6	88	88
20	8	141	141
25	10	219	219

Working Fluid:

Filtered and lubricated or filtered and not lubricated air

Operating Temperature Range:

Polyurethane (PU) : (-20°C) - (+80°C)

Viton (FKM) : (-30°C) - (+180°C)

Max. Work Pressure:

10 Bar

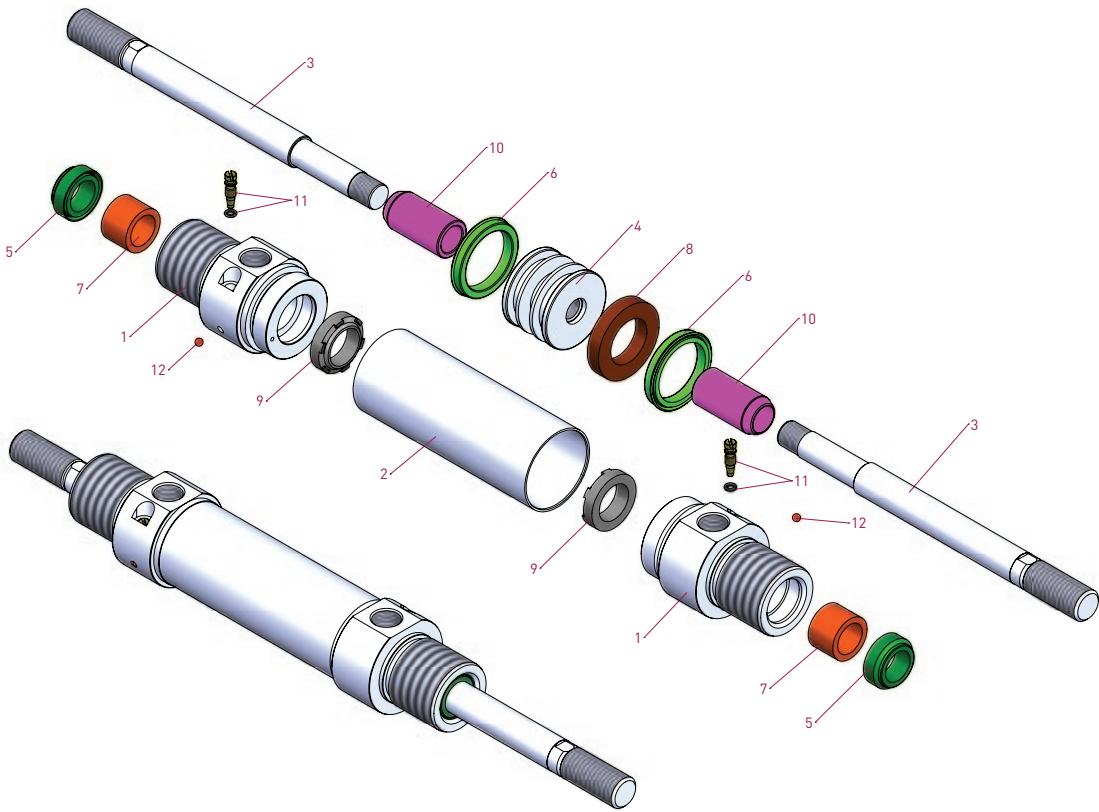
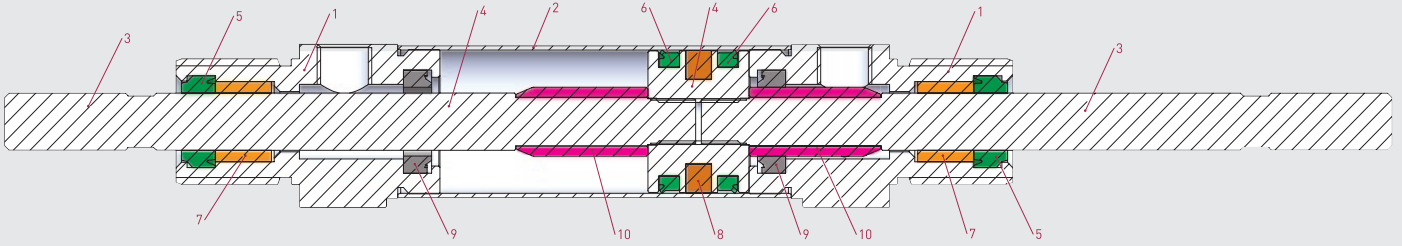

No	MATERIAL NAME	CHARACTERISTIC	PC.
1	Head	Aluminium	2
2	Tube	SS 304	1
3	Piston Rod	SS 303	2
4	Middle Piston	Brass	1
5	Rod Seal	PU	2
6	Piston Seal	PU	2

No	MATERIAL NAME	CHARACTERISTIC	PC.
7	Guidind Bush	Sinterized Bronze	2
8	Magnet		1
9	Cushioning Seal	NBR	2
10	Cushioning Tube	Aluminium	2
11	Cushioning Screw	Aluminium	2
12	Marble		2

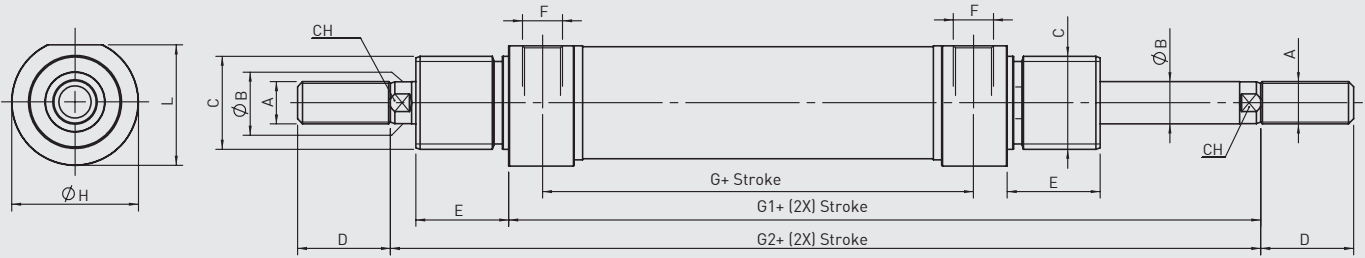

PMDY-A SERIES
ISO 6432 - Ø16 - Ø25

Cylinder Ø mm	A	ØB	C	D	E	F	G	G1	G2	ØH	L	CH
16	M6	6	M16x1.5	16	18	M5	43	75	97	19	18	5
20	M8	8	M22x1.5	20	20	1/8" G	51,5	91	115	27	25,5	7
25	M10x1.25	10	M22x1.5	22	22	1/8" G	52	96	124	30	28,5	9

SF SWIVEL FLANGE

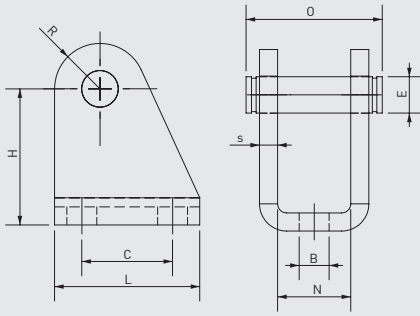

Cylinder Ø mm	B H13	E f8	C JS13	H ±0.2	L	N E9	O	R max	S ±0.2
8-10	4,5	4	12,5	24	20	8,1	17	5	2,5
12-16	5,5	6	15	27	25	12,1	23	7	3
20-25	6,6	8	20	30	32	16,1	29,5	10	4

FM FLANGE MOUNTING

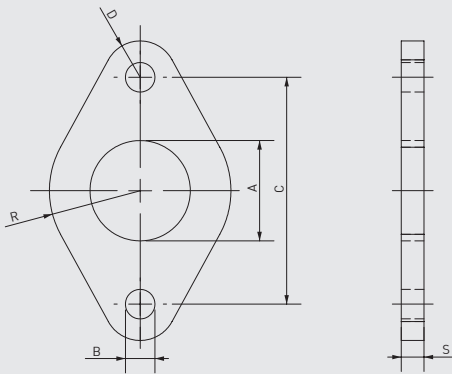

Cylinder Ø mm	A +0.3 +0.1	B H13	C JS13	R ±0.2	G ±0.2	S ±0.2
8-10	12	4,5	30	11	5	3
12-16	16	5,5	40	15	6	4
20-25	22	6,6	50	20	8	5

FM FOOT MOUNTING

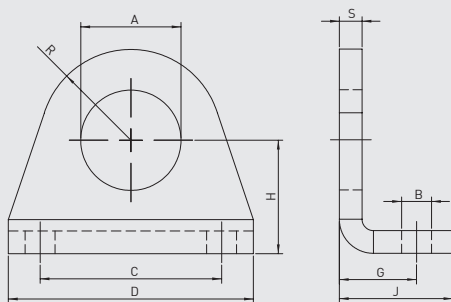

Cylinder Ø mm	A +0.2 +0.1	B H13	C JS13	D	G +0.3 0	H ±0.2	J	R max	S ±0.2
8-10	12	4,5	25	35	11	16	16	10	3
12-16	16	5,5	32	42	14	20	20	12,5	4
20-25	22	6,6	40	54	17	25	25	20	5

RC ROD CLEVIS

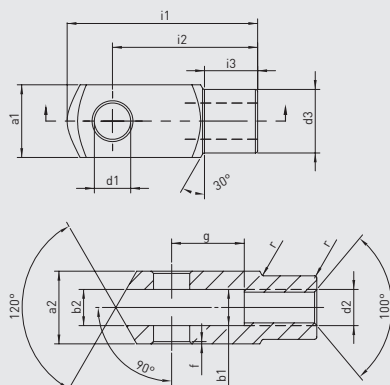

Cylinder Ø mm	d1 H9	g ±0.5	a1 h11	a2 +0.3 -0.16	b1 B13	b2	d2 6H	d3 ±0.3	f ±0.2	i1 ±0.5	i2	i3 ±0.2	r
8-10	4	8	8	8	4	4	M4x0.70	8	0,5	21	16	6	0,5
12-16	6	12	12	12	6	6	M6x1.00	10	0,5	31	24	9	0,5
20	8	16	16	16	8	8	M8x1.25	14	0,5	42	32	12	0,5
25	10	20	20	20	10	10	M10x1.25	18	0,5	52	40	15	0,5

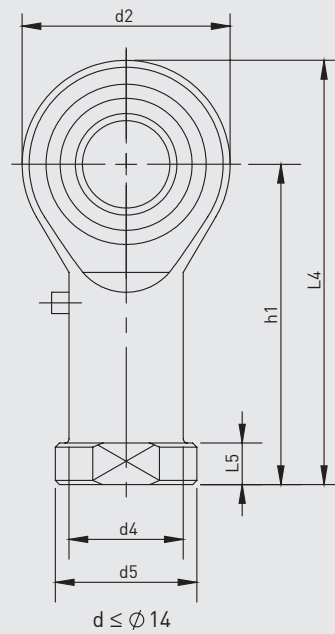
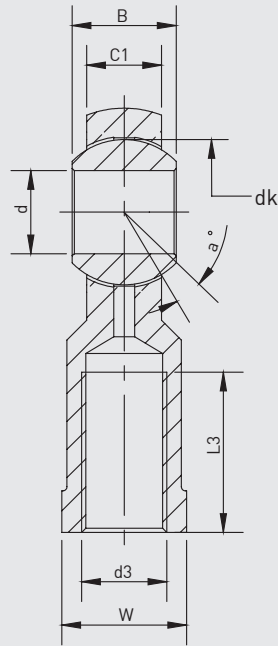

Part No.	Dimensions (mm)													
	d	d3 6H	B	C1	w	L3 min	d2	L4	h1	L5	d4	d5	dk	a°
KMB 6	6	M6x1.0	9	6,75	11	12	18	39	30	5	10	13	12,7	13
KMB 8	8	M8x1.25	12	9	14	16	22	47	36	5	12,5	16	15,875	14
KMB 10-1	10	M10x1.25	14	10,5	17	20	26	56	43	6,5	15	19	19,05	13

**COMPACT
PNEUMATIC CYLINDERS
PK-A SERIES Ø20- Ø25**





PK-A SERIES
COMPACT - Ø20 - Ø25

COMPACT MAGNETIC CYLINDER

NEED HIGHER POWER
IN A TIGHTER SPACE?
PK-A IS THE PERFECT CHOICE



PK: COMPACT CYLINDERS WITH
DOUBLE ACTING



PK-A: MAGNETIC COMPACT
CYLINDERS WITH DOUBLE ACTING

Example of order:

PK-A
Product Code

020-025
Cylinder Ø
Stroke

R1 K4
Variants from
Standard System

VARIANTS FROM STANDARD SYSTEM:

- R1: Stainless Steel Piston Rod (SS 304-SS 316)
- R4: Stainless Steel Nut for Piston Rod (SS 304)
- R5: Piston Rod as CK45 (Hard Chrome Plated)
- M1: Extended male Piston Rod Thread
- M3: Special Piston Rod Thread
- M4: Extended Piston Rod
- K4: Piston Rod Seal Viton

Force:

Cylinder Ø mm	Rod Ø mm	Thrust and traction forces (6 Bar)	
		Thrust Force (N)	Traction Force (N)
20	10	170	127
25	10	265	222

Working Fluid:

Filtered and lubricated or filtered and not lubricated air

Operating Temperature Range:

Polyurethane (PU) : (-20°C) - (+80°C)
Viton (FKM) : (-30°C) - (+180°C)

Max. Work Pressure:

10 Bar



PK-A SERIES
COMPACT - Ø20 - Ø25

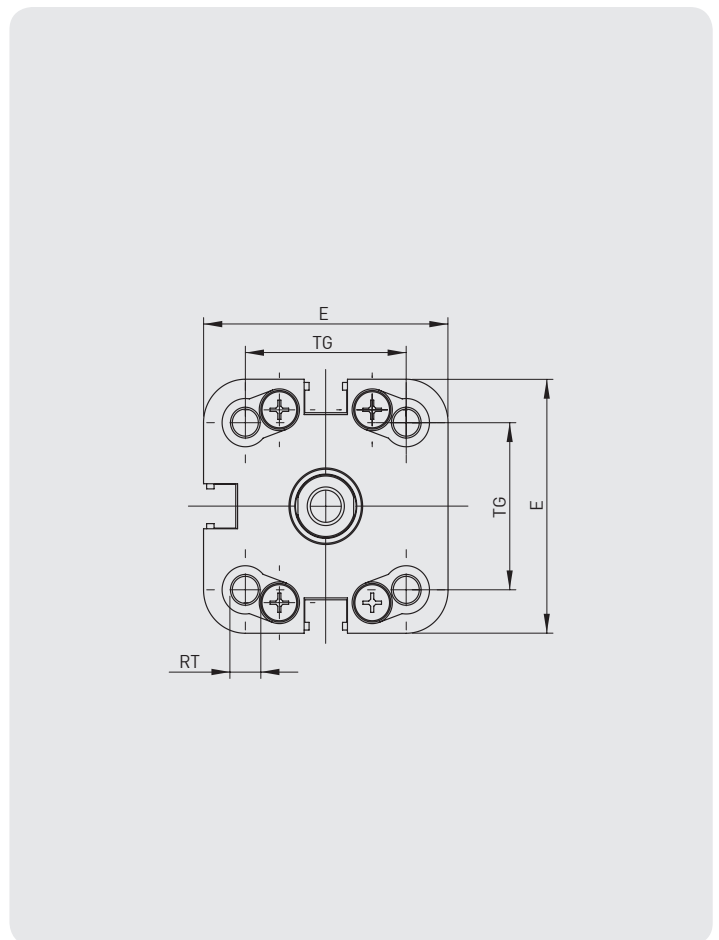
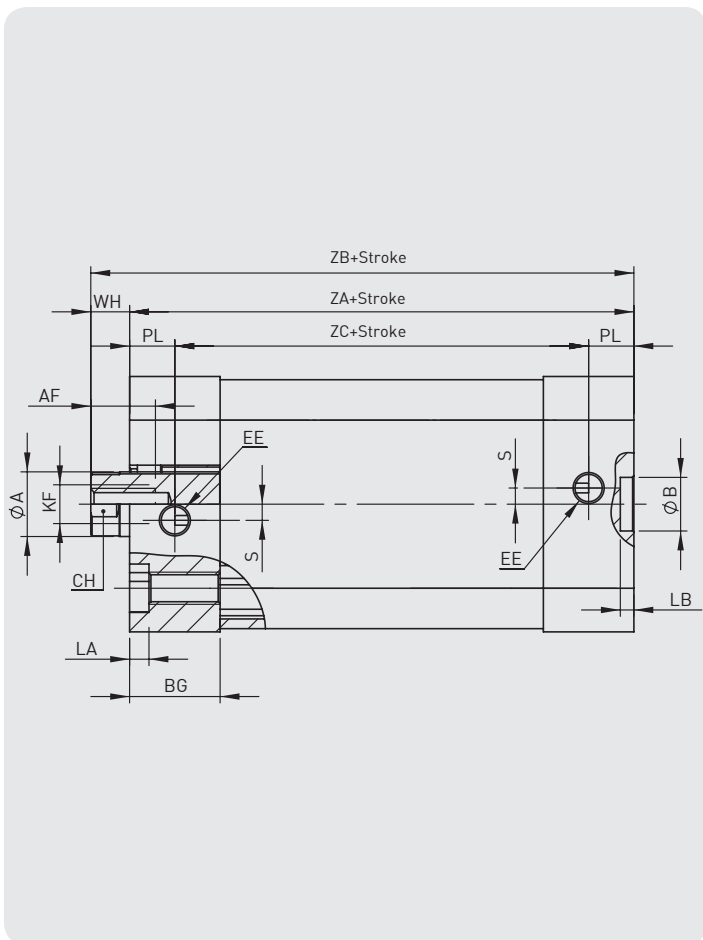

Cylinder Ø mm	ØA	CH	AF	WH	ZA	ZB	ZC	KF	EE	BG	TG	E	RT	LA	PL	ØB	LB	S
20	10	9	10	6	37	43	23	M6x1	M5x0.8	14,25	22	36	M5x0.8	3	7	9	2,1	2,5
25	10	9	10	6	39	45	25	M6x1	M5x0.8	14	26	39,5	M5x0.8	3	7	9	2,1	2,5



PK-T

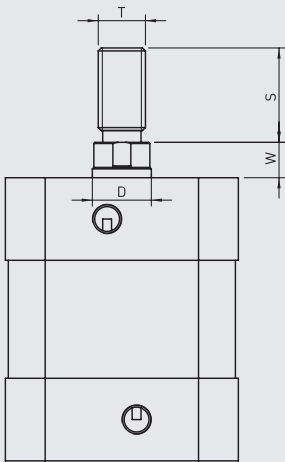

PKS-T

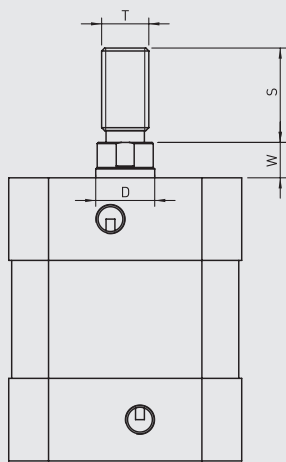

PKD-T

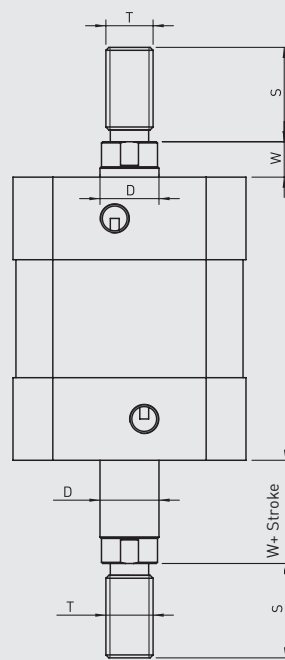

PKE-T

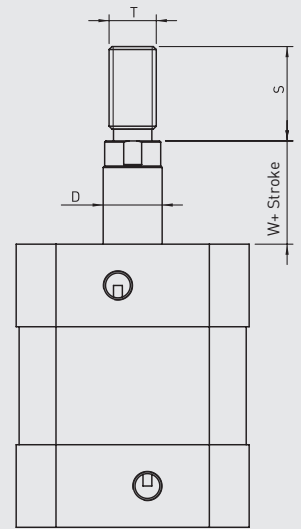

Cylinder type	Cylinder Ø mm	D	S	T	W
PK-PKS	20	10	16	M8x1.25	6
PKE-PKD	25	10	16	M8x1.25	6

**COMPACT
PNEUMATIC CYLINDERS
PKD-A SERIES Ø20- Ø25**





PKD-A SERIES
COMPACT - Ø20 - Ø25

COMPACT DOUBLE-ROD CYLINDER
WITH MAGNET

POSSIBILITY FOR DOUBLE
DIRECTION RUN WITH IDENTITY
STROKES COMPACT DIMENSIONS

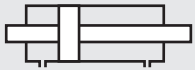

PKD: COMPACT CYLINDERS WITH
DOUBLE ACTING WITH DOUBLE ROD



PKD-A: COMPACT MAGNETIC
CYLINDERS WITH DOUBLE ACTING
WITH DOUBLE ROD

Example of order:

PKD-A
Product Code

020-050
Cylinder Ø
Stroke

M1 M3
Variants from
Standard System

VARIANTS FROM STANDARD SYSTEM:

- R1: Stainless Steel Piston Rod (SS 304-SS 316)
- R4: Stainless Steel Nut for Piston Rod (SS 304)
- R5: Piston Rod as CK45 (Hard Chrome Plated)
- M1: Extended male Piston Rod Thread
- M3: Special Piston Rod Thread
- M4: Extended Piston Rod
- K4: Piston Rod Seal Viton

Force:

Cylinder Ø mm	Rod Ø mm	Thrust and traction forces (6 Bar)	
		Thrust Force (N)	Traction Force (N)
20	10	127	127
25	10	222	222

Working Fluid:

Filtered and lubricated or filtered and not lubricated air

Operating Temperature Range:

Polyurethane (PU) : (-20°C) - (+80°C)
Viton (FKM) : (-30°C) - (+180°C)

Max. Work Pressure:

10 Bar



PKD-A SERIES
COMPACT - Ø20 - Ø25

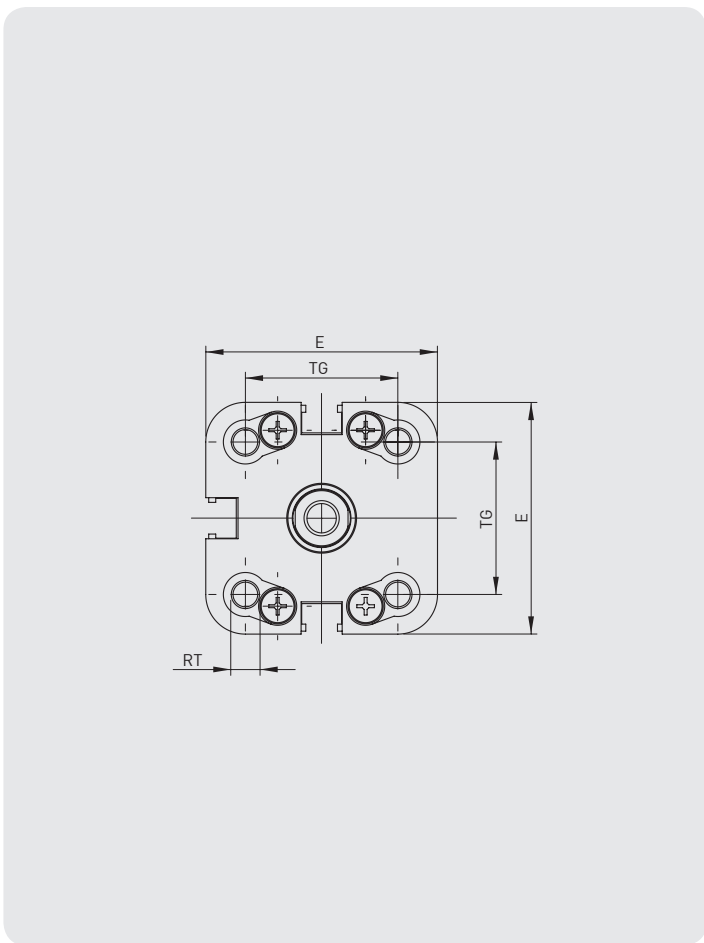
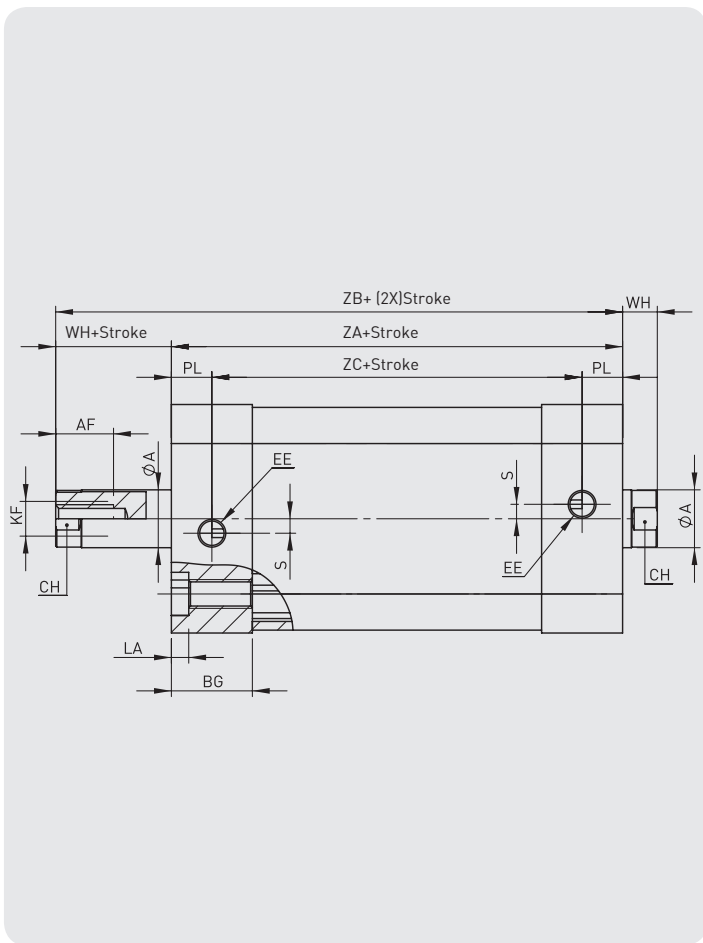

Cylinder Ø mm	ØA	CH	AF	WH	ZA	ZB	ZC	KF	EE	BG	TG	E	RT	LA	PL	ØB	LB	S
20	10	9	10	6	37	43	23	M6x1	M5x0.8	14,25	22	36	M5x0.8	3	7	9	2,1	2,5
25	10	9	10	6	39	45	25	M6x1	M5x0.8	14	26	39,5	M5x0.8	3	7	9	2,1	2,5



PK-T

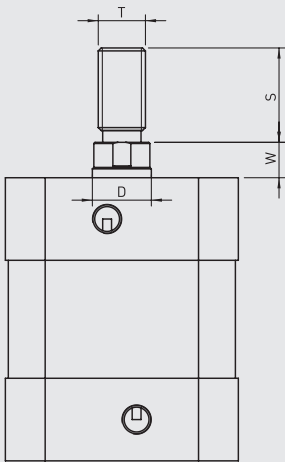

PKS-T

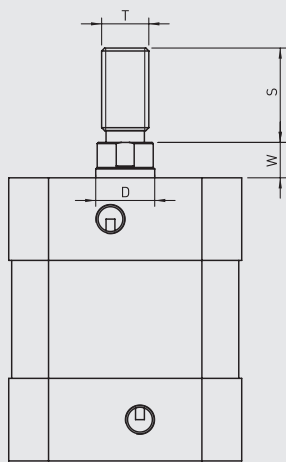

PKD-T

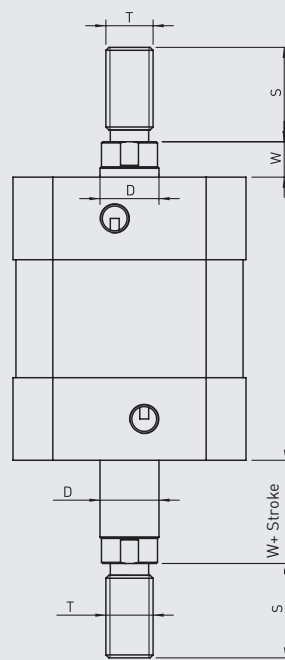

PKE-T

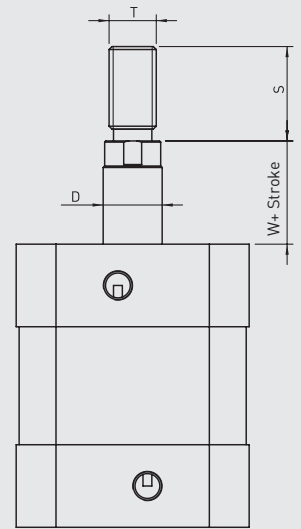

Cylinder type	Cylinder Ø mm	D	S	T	W
PK-PKS	20	10	16	M8x1.25	6
PKE-PKD	25	10	16	M8x1.25	6

**COMPACT
PNEUMATIC CYLINDERS
PKE-A SERIES Ø20- Ø25**





PKE-A SERIES
COMPACT - Ø20 - Ø25

COMPACT, MAGNETIC CYLINDER
WITH REAR SPRING

WITH SINGLE ACTING USAGE
PROVIDES MINIMUM AIR
CONSUMPTION AND EQUIPMENT
COSTS



PKE: COMPACT CYLINDERS WITH
SINGLE ACTING (SPRINGED FROM
BACK)



PKE-A: MAGNETIC COMPACT
CYLINDERS WITH SINGLE ACTING
(SPRINGED FROM BACK)

Example of order:

PKE-A
Product Code

020-025
Cylinder Ø
Stroke

R1
Variants from
Standard System

VARIANTS FROM STANDARD SYSTEM:

- R1: Stainless Steel Piston Rod (SS 304-SS 316)
- R4: Stainless Steel Nut for Piston Rod (SS 304)
- R5: Piston Rod as CK45 (Hard Chrome Plated)
- M1: Extended male Piston Rod Thread
- M3: Special Piston Rod Thread
- M4: Extended Piston Rod
- K4: Piston Rod Seal Viton

Force:

Cylinder Ømm	Rod Ømm	Traction Force (N)	Thrust and traction forces (6 Bar)									
			Thrust Force (N)									
			Stroke5		Stroke10		Stroke15		Stroke20		Stroke25	
			F1	F2	F1	F2	F1	F2	F1	F2	F1	F2
20	10	118	8	9	7	9	6	9	5	9	4	9
25	10	201	19	22	16	22	13	22	10	22	7	22

Working Fluid:

Filtered and lubricated or filtered and not lubricated air

Operating Temperature Range:

Polyurethane (PU) : (-20°C) - (+80°C)

Viton (FKM) : (-30°C) - (+180°C)

Max. Work Pressure:

10 Bar



PKE-A SERIES
COMPACT - Ø20 - Ø25

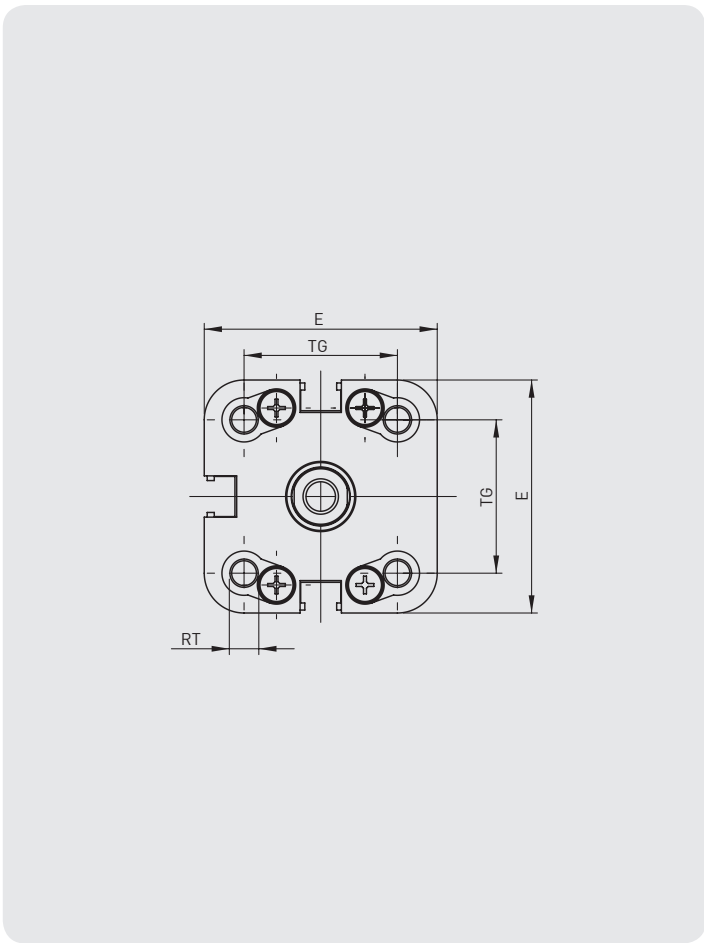
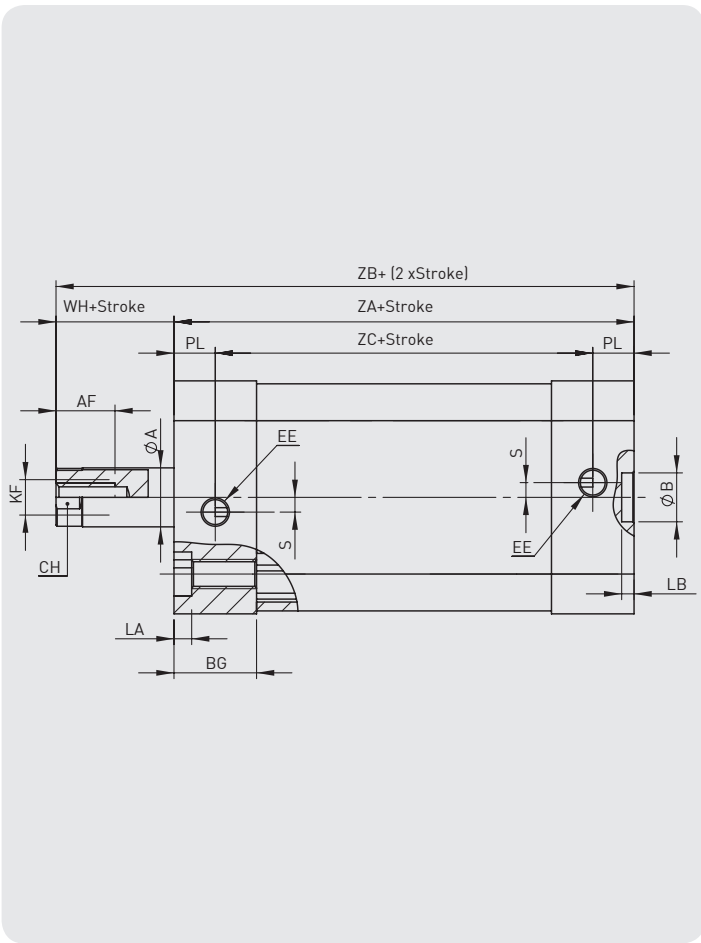

Cylinder Ø mm	ØA	CH	AF	WH	ZA	ZB	ZC	KF	EE	BG	TG	E	RT	LA	PL	ØB	LB	S
20	10	9	10	6	37	43	23	M6x1	M5x0.8	14,25	22	36	M5x0.8	3	7	9	2,1	2,5
25	10	9	10	6	39	45	25	M6x1	M5x0.8	14	26	39,5	M5x0.8	3	7	9	2,1	2,5



PK-T

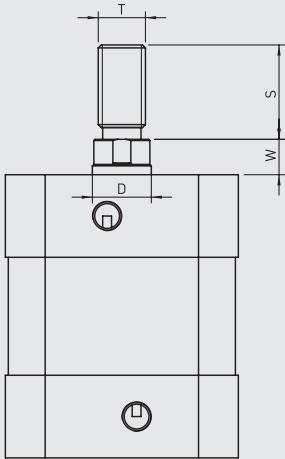

PKS-T

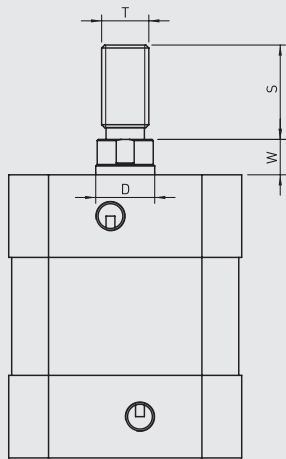

PKD-T

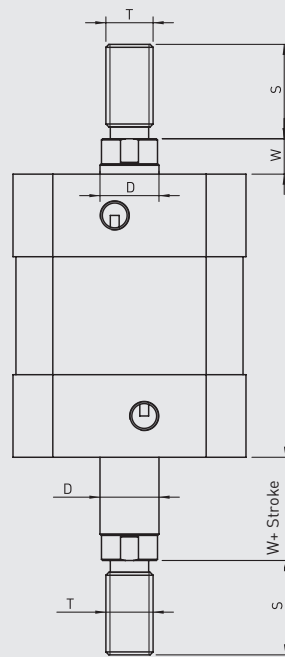

PKE-T

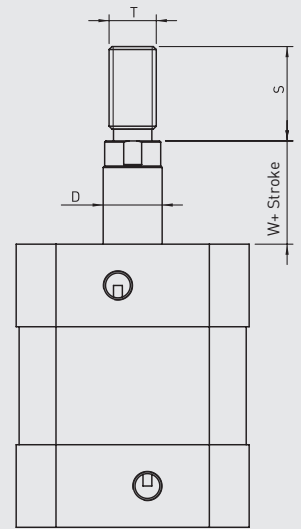

Cylinder type	Cylinder Ø mm	D	S	T	W
PK-PKS	20	10	16	M8x1.25	6
PKE-PKD	25	10	16	M8x1.25	6

**COMPACT
PNEUMATIC CYLINDERS
PKS-A SERIES Ø20- Ø25**





PKS-A SERIES
COMPACT - Ø20 - Ø25

COMPACT, MAGNETIC CYLINDER
WITH FRONT SPRING

WITH SINGLE ACTING USAGE
PROVIDES MINIMUM AIR
CONSUMPTION AND EQUIPMENT
COSTS



PKS: COMPACT CYLINDERS WITH
SINGLE ACTING (SPRINGED FROM
FRONT)



PKS-A: MAGNETIC COMPACT
CYLINDERS WITH SINGLE ACTING
(SPRINGED FROM FRONT)

Example of order:

PKS-A
Product Code

020-050
Cylinder Ø
Stroke

M4
Variants from
Standard System

VARIANTS FROM STANDARD SYSTEM:

- R1: Stainless Steel Piston Rod (SS 304-SS 316)
- R4: Stainless Steel Nut for Piston Rod (SS 304)
- R5: Piston Rod as CK45 (Hard Chrome Plated)
- M1: Extended male Piston Rod Thread
- M3: Special Piston Rod Thread
- M4: Extended Piston Rod
- K4: Piston Rod Seal Viton

Force:

Cylinder Ømm	Rod Ømm	Thrust Force (N)	Thrust and traction forces (6 Bar)									
			Traction Force (N)									
			Stroke5		Stroke10		Stroke15		Stroke20		Stroke25	
			F1	F2	F1	F2	F1	F2	F1	F2	F1	F2
20	10	160	8	9	7	9	6	9	5	9	4	9
25	10	243	19	22	16	22	13	22	10	22	7	22

Working Fluid:

Filtered and lubricated or filtered and not lubricated air

Operating Temperature Range:

Polyurethane (PU) : (-20°C) - (+80°C)

Viton (FKM) : (-30°C) - (+180°C)

Max. Work Pressure:

10 Bar



PKS-A SERIES
COMPACT - Ø20 - Ø25

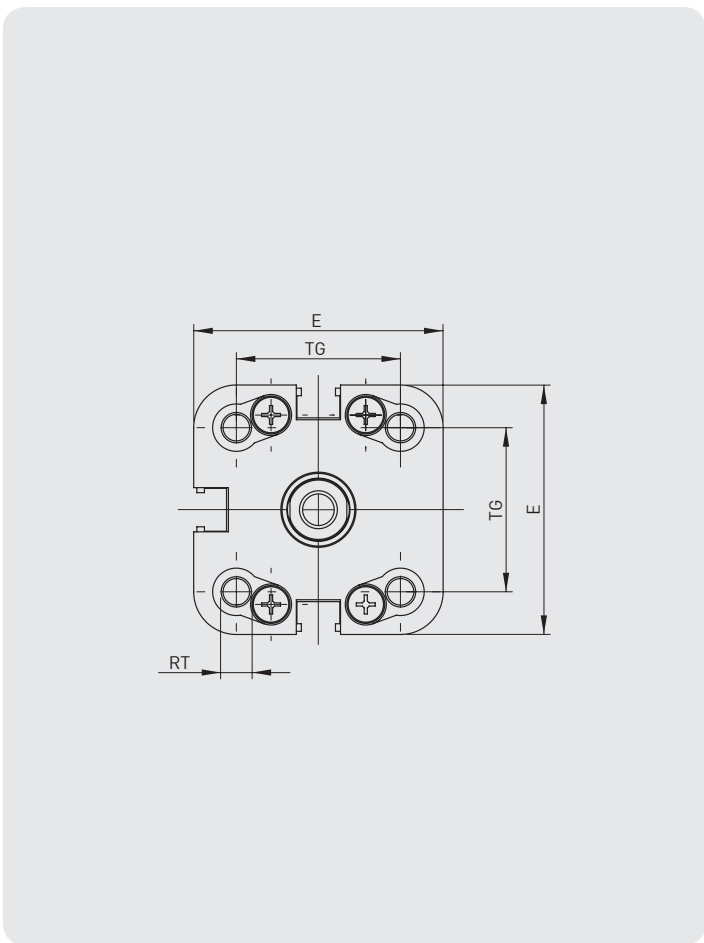
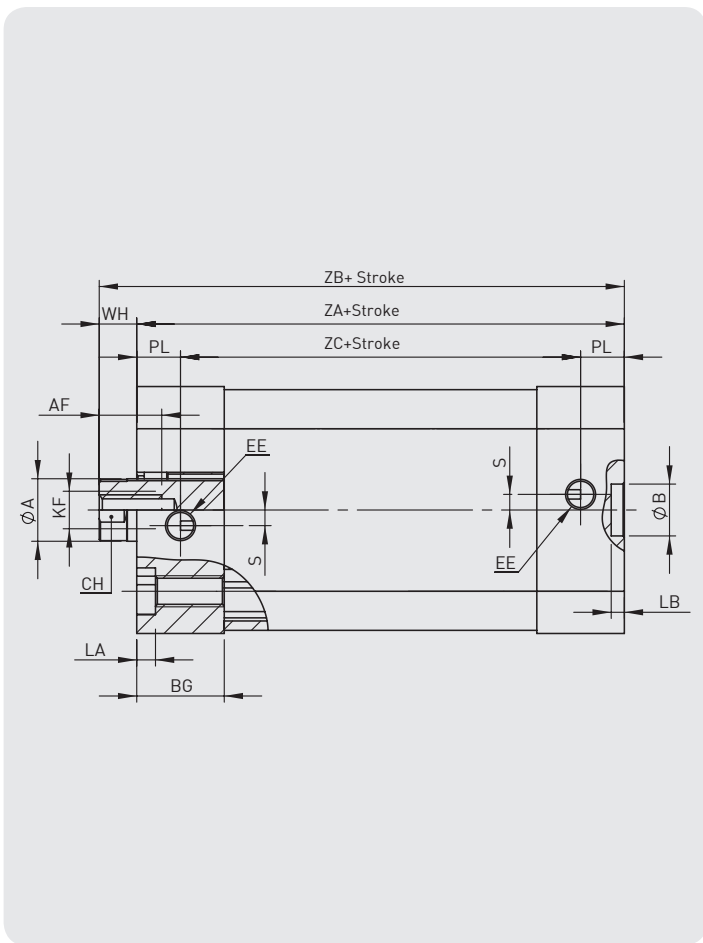

Cylinder Ø mm	ØA	CH	AF	WH	ZA	ZB	ZC	KF	EE	BG	TG	E	RT	LA	PL	ØB	LB	S
20	10	9	10	6	37	43	23	M6x1	M5x0.8	14,25	22	36	M5x0.8	3	7	9	2,1	2,5
25	10	9	10	6	39	45	25	M6x1	M5x0.8	14	26	39,5	M5x0.8	3	7	9	2,1	2,5



PK-T

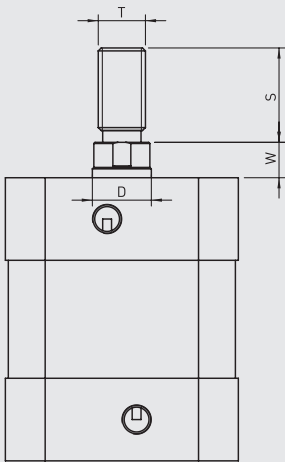

PKS-T

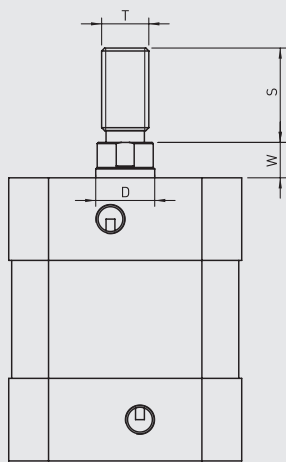

PKD-T

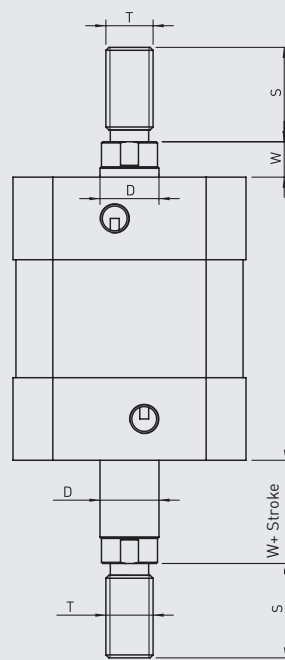

PKE-T

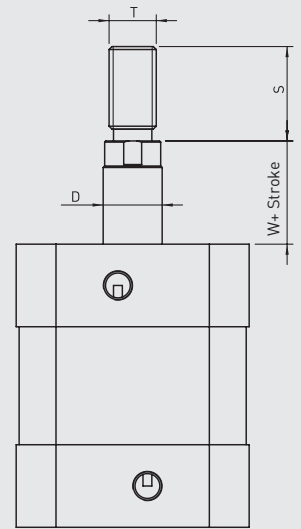

Cylinder type	Cylinder Ø mm	D	S	T	W
PK-PKS	20	10	16	M8x1.25	6
PKE-PKD	25	10	16	M8x1.25	6

**COMPACT
PNEUMATIC CYLINDER
PK-A SERIES Ø32- Ø100**





PK-A SERIES

COMPACT - Ø32 - Ø100

COMPACT MAGNETIC CYLINDER

NEED HIGHER POWER IN A TIGHTER SPACE? PK-A IS THE PERFECT CHOICE



PK: COMPACT CYLINDERS WITH DOUBLE ACTING



PK-A: MAGNETIC COMPACT CYLINDERS WITH DOUBLE ACTING

Example of order:

PK-A
Product Code

032-025
Cylinder Ø
Stroke

K1 M1
Variants from
Standard System

VARIANTS FROM STANDARD SYSTEM:

- R1: Stainless Steel Piston Rod (SS 304-SS 316)
- R4: Stainless Steel Nut for Piston Rod (SS 304)
- R5: Piston Rod as CK45 (Hard Chrome Plated)
- M1: Extended male Piston Rod Thread
- M3: Special Piston Rod Thread
- M4: Extended Piston Rod
- K1: Seals for Max. 150°C (Viton)
- K4: Piston Rod Seal Viton

Force:

Cylinder Ø mm	Rod Ø mm	Thrust and traction forces (6 Bar)	
		Thrust Force (N)	Traction Force (N)
32	12	482	415
40	12	754	687
50	16	1178	1058
63	16	1869	1750
80	20	3014	2829
100	25	4710	4420

Working Fluid:

Filtered and lubricated or filtered and not lubricated air

Operating Temperature Range:

Polyurethane (PU) : (-20°C) - (+80°C)
 Viton (FKM) : (-30°C) - (+180°C)

Max. Work Pressure:

10 Bar

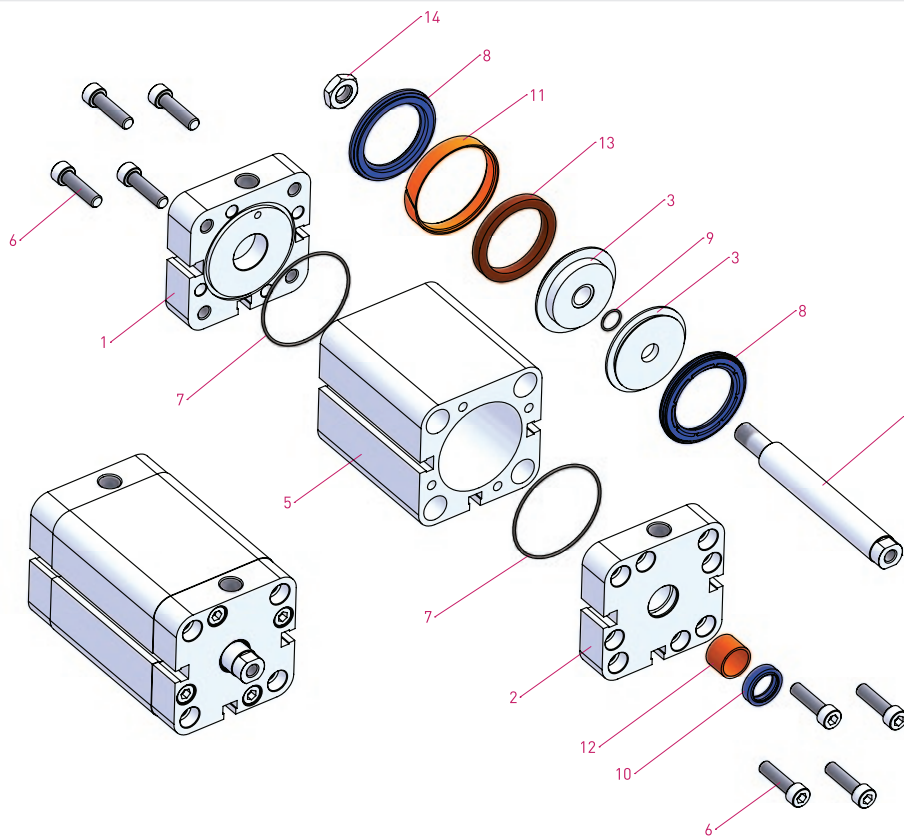
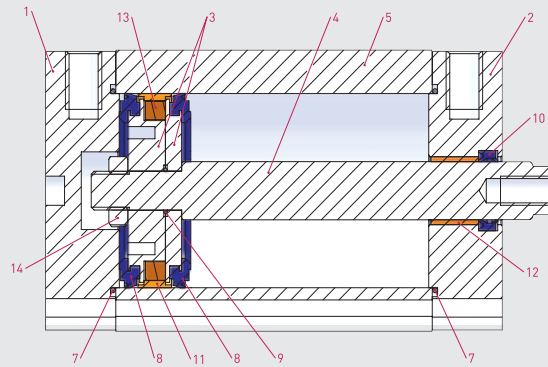

No	MATERIAL NAME	CHARACTERISTIC	PC.
1	Rear Head	Aluminium	1
2	Front Head	Aluminium	1
3	Middle Piston	Aluminium	2
4	Piston Rod	X20 Cr13 Hard Chrome Plated	1
5	Tube	Al Mg S 0,5+Eloxal Plated	1
6	Bolt	Stainless Steel	8
7	Head O-ring	NBR	2

No	MATERIAL NAME	CHARACTERISTIC	PC.
8	Piston Seal	PU	2
9	Middle Piston O-ring	NBR	1
10	Rod Seal	PU	1
11	Guiding Band	Polyacetal	1
12	Guiding Bush	CSB-40	1
13	Magnet		1
14	Nut	Galvanized Steel	1



PK-A SERIES
COMPACT - Ø32 - Ø100

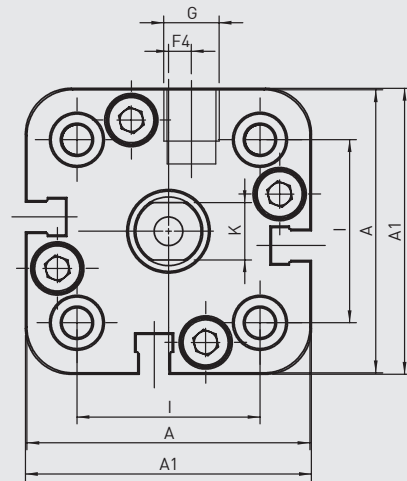
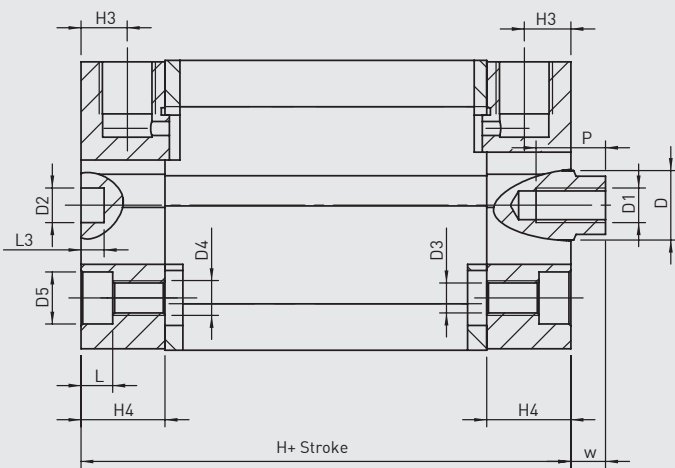

Cylinder Ø mm	A	A1	D Ø	D1 Ø	D2 Ø	D3 Ø	D4 Ø	D5 Ø	F4	G	H	H3	H4	I	K	L	L3	P	W
32	49,5	50	12	M6	6	5,2	M6	9	4	1/8"	44,5	8	14,5	32	10	5,5	4	12	6
40	57,5	58	12	M6	6	5,2	M6	9	3	1/8"	45,5	8	14,75	42	10	5,5	4	12	6,5
50	66,5	67	16	M8	6	6,7	M8	10,5	0	1/8"	45,5	8	14,75	50	13	6,5	4	12	7,5
63	79,5	80	16	M8	8	8,7	M10	13,5	0	1/8"	50	8	14,75	62	13	8,5	4	14	7,5
80	99,5	100	20	M10	8	8,7	M10	13,5	0	1/8"	56	8,5	16,5	82	17	8,5	4	15	8
100	123,5	124	25	M12	8	8,7	M10	13,5	0	1/4"	66,5	10,5	19,75	103	22	8,5	4	20	10

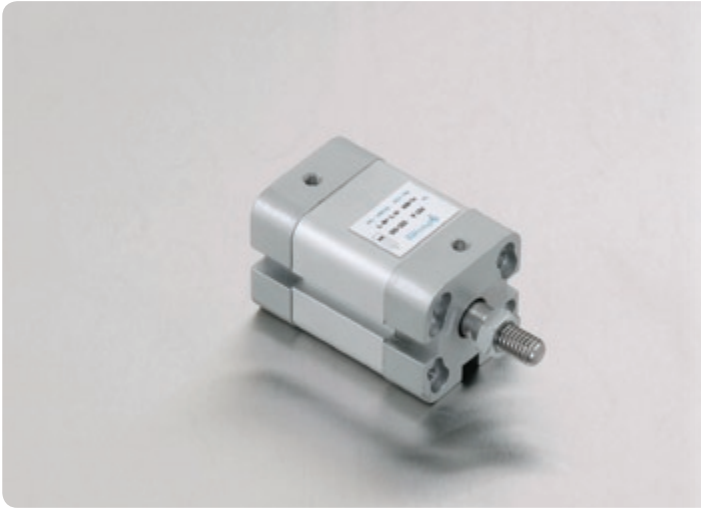

PK-T

PKS-T

PKE-T

PKD-T

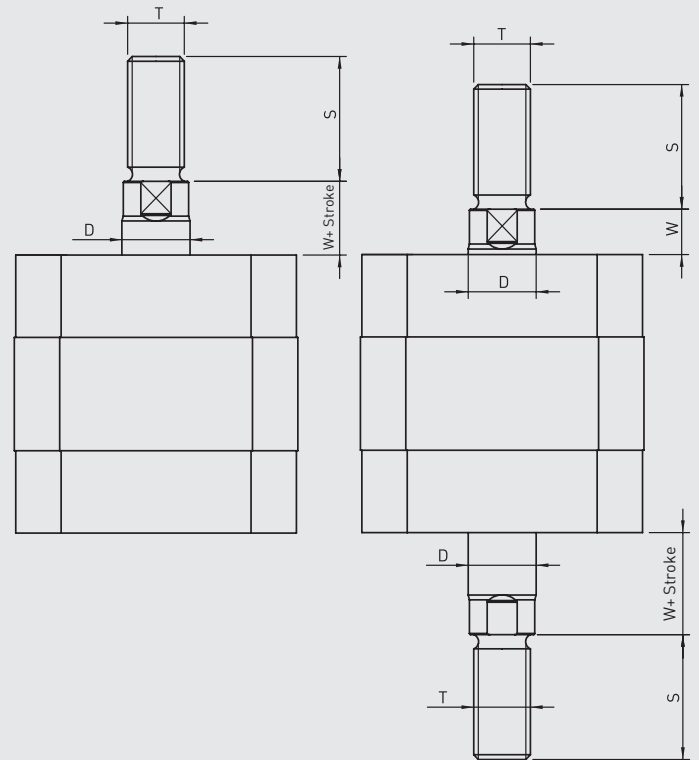
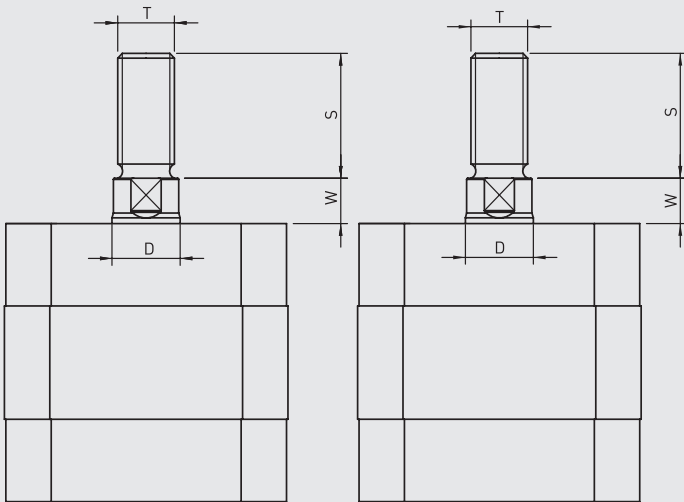

Cylinder type	Cylinder Ø mm	D	S	T	W
	32	12	22	M10x1.25	6
	40	12	22	M10x1.25	6.5
PK-PKS	50	16	24	M12x1.25	7.5
PKE-PKD	63	16	24	M12x1.25	7.5
	80	20	32	M16x1.5	8
	100	25	40	M20x1.5	10

**COMPACT
PNEUMATIC CYLINDERS
PKY-A SERIES Ø32- Ø100**





PKY-A SERIES

COMPACT - Ø32 - Ø100

ANTIROTARY COMPACT CYLINDER
WITH MAGNET

SUITABLE FOR USE IN CARRIAGE
AND TAKE POSITION WITH
ANTIROTARY PISTON ROD
SPECIALTY

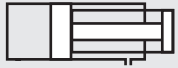

PKY: ANTIROTARY - COMPACT
CYLINDERS WITH DOUBLE ACTING



PKY-A: ANTIROTARY - MAGNETIC -
COMPACT CYLINDERS WITH DOUBLE
ACTING

Example of order:

PKY-A

Product Code

032-100

Cylinder Ø
Stroke

R1 K1

Variants from
Standard System

VARIANTS FROM STANDARD SYSTEM:

R1: Stainless Steel Piston Rod (SS 304-SS 316)

R4: Stainless Steel Nut for Piston Rod (SS 30)

R5: Piston Rod as CK45 (Hard Chrome Plated)

M4: Extended Piston Rod

K1: Seals for Max. 150°C (Viton)

K4: Piston Rod Seal Viton

Force:

Cylinder Ø mm	Rod Ø mm	Thrust and traction forces (6 Bar)	
		Thrust Force (N)	Traction Force (N)
32	12	482	415
40	12	754	687
50	16	1178	1058
63	16	1869	1750
80	20	3014	2829
100	25	4710	4420

Working Fluid:

Filtered and lubricated or filtered and not lubricated air

Operating Temperature Range:

Polyurethane (PU) : (-20°C) - (+80°C)

Viton (FKM) : (-30°C) - (+180°C)

Max. Work Pressure:

10 Bar

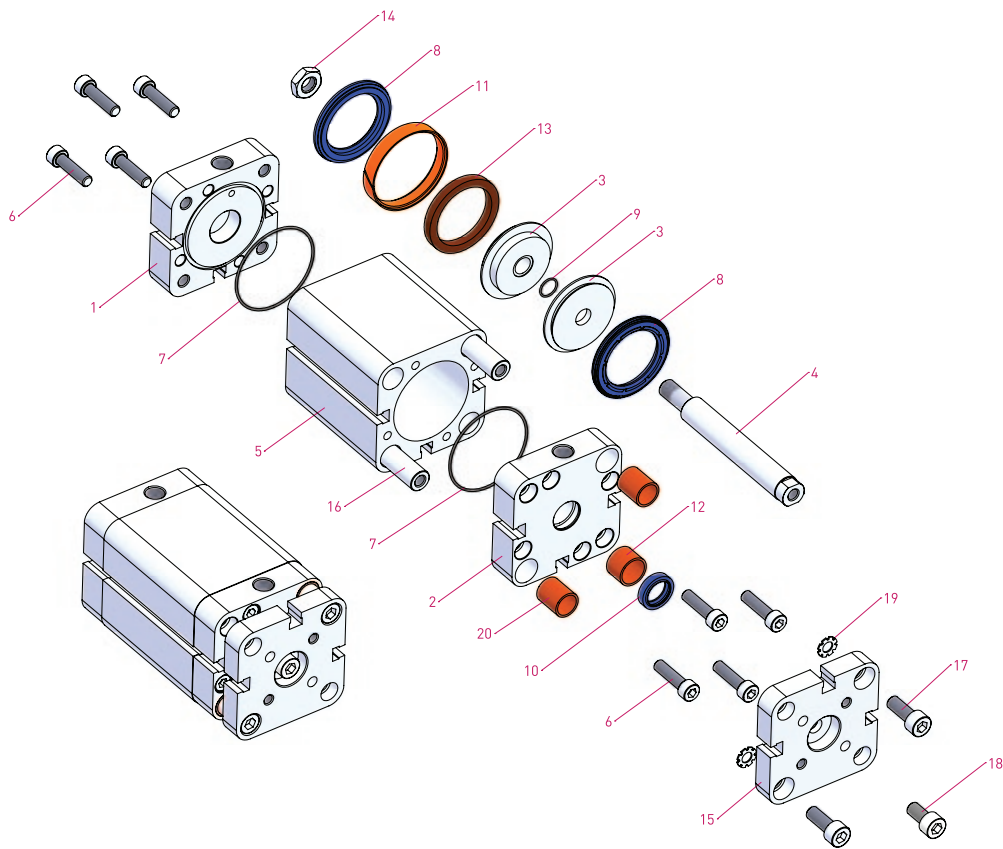
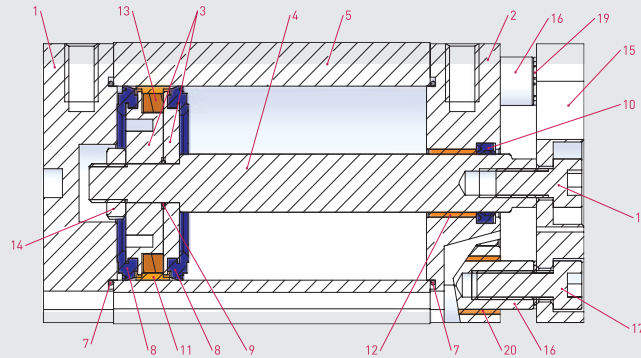

No	MATERIAL NAME	CHARACTERISTIC	PC.
1	Rear Head	Aluminium	1
2	Front Head	Aluminium	1
3	Middle Piston	Aluminium	2
4	Piston Rod	X20 Cr13 Hard Chrome Plated	1
5	Tube	Al Mg Si 0,5+Eloxal Plated	1
6	Bolt	Stainless Steel	8
7	Head O-ring	NBR	2
8	Piston Seal	PU	2
9	Middle Piston O-ring	NBR	1
10	Rod Seal	PU	1

No	MATERIAL NAME	CHARACTERISTIC	PC.
11	Guiding Band	Polyacetal	1
12	Guiding Bush	CSB-40	1
13	Magnet		1
14	Nut	Galvanized Steel	1
15	Braket	Aluminium	1
16	Rod	X20Cr13 Hard Chrome Plated	2
17	Bolt	Galvanized Steel	2
18	Bolt	Galvanized Steel	1
19	Rondela		2
20	Guiding Bush	CSB-40	2



PKY-A SERIES
COMPACT - Ø32 - Ø100

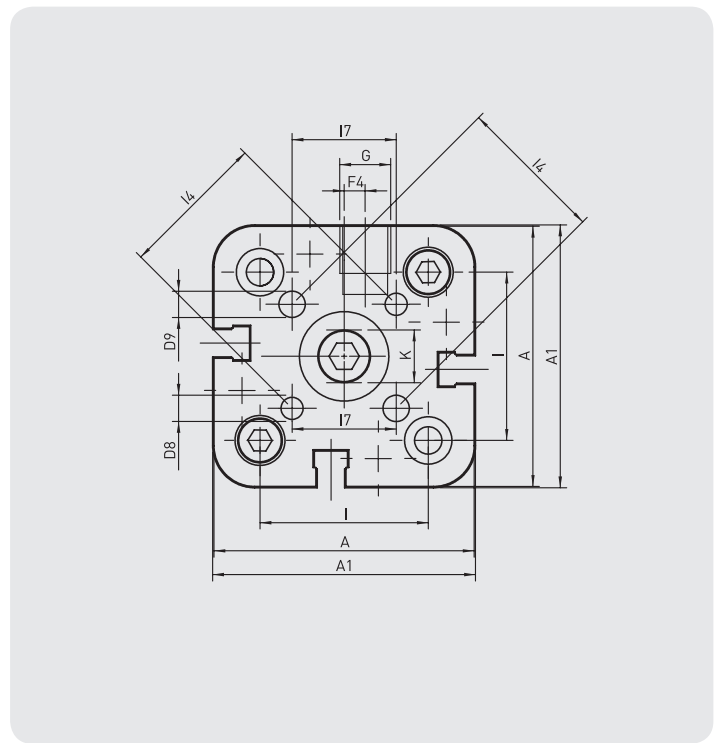
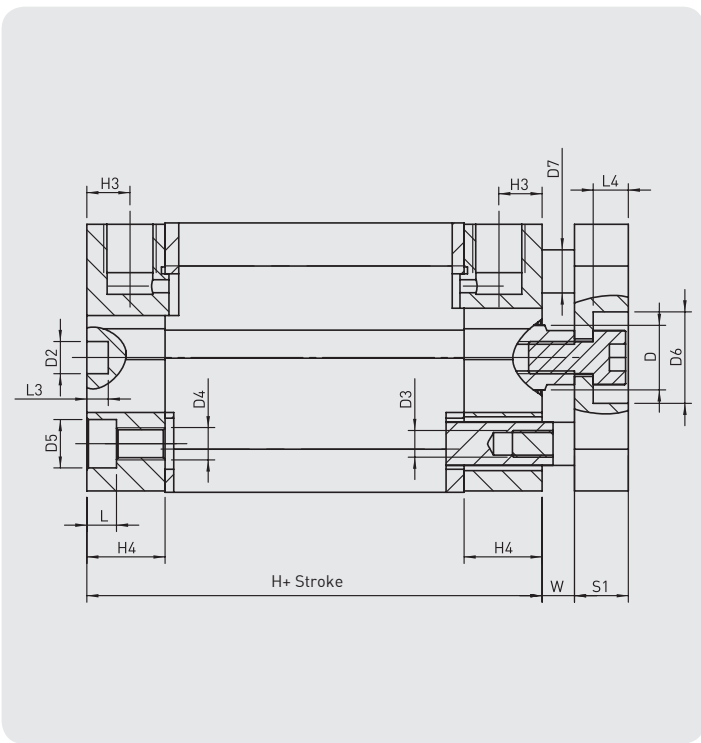

Cylinder Ø mm	A	A1	D Ø	D2 Ø	D3 Ø	D4 Ø	D5 Ø	D6 Ø	D7 Ø	D8 Ø	D9 Ø	F4
32	49,5	50	12	6	5,2	M6	9	17	8	M5	5	4
40	57,5	58	12	6	5,2	M6	9	17	10	M5	5	3
50	66,5	67	16	6	6,7	M8	10,5	22	10	M6	6	0
63	79,5	80	16	8	8,7	M10	13,5	22	10	M6	6	0
80	99,5	100	20	8	8,7	M10	13,5	28	14	M8	8	0
100	123,5	124	25	8	8,7	M10	13,5	30	14	M10	10	0

G	H	H3	H4	I	I4	I7	K	L	L3	L4	S1	W
1/8"	44,5	8	14,5	32	28	19,8	10	5,5	4	6,5	10	6
1/8"	45,5	8	14,75	42	33	23,3	10	5,5	4	6,5	10	6,5
1/8"	45,5	8	14,75	50	42	29,7	13	6,5	4	8,5	12	7,5
1/8"	50	8	14,75	62	50	35,4	13	8,5	4	8,5	12	7,5
1/8"	56	8,5	16,5	82	65	46	17	8,5	4	9	14	8
1/4"	66,5	10,5	19,75	103	80	56,6	22	8,5	4	10	14	10

**COMPACT
PNEUMATIC CYLINDERS
PKD-A SERIES Ø32- Ø100**



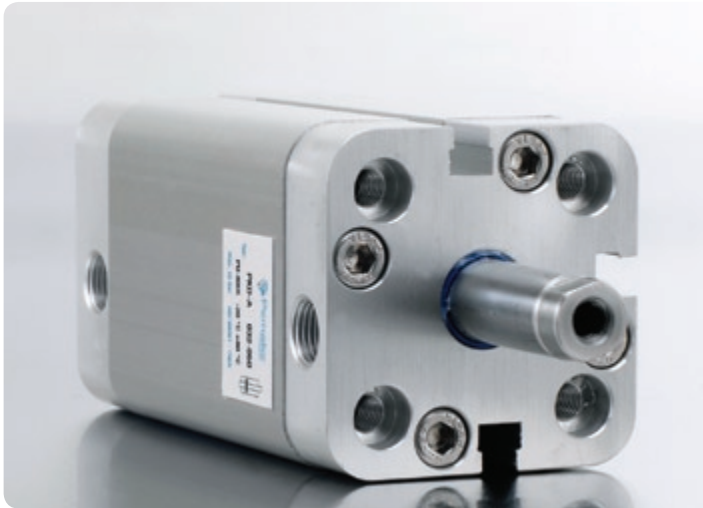

PKD-A SERIES

COMPACT - Ø32 - Ø100

COMPACT CYLINDER
WITH MAGNET AND DOUBLE ROD

POSSIBILITY FOR DOUBLE
DIRECTION RUN WITH IDENTITY
STROKES COMPACT DIMENSION



PKD: COMPACT CYLINDERS WITH
DOUBLE ACTING WITH DOUBLE ROD



PKD-A: COMPACT MAGNETIC
CYLINDERS WITH DOUBLE ACTING
WITH DOUBLE ROD

Example of order:

PKD-A
Product Code

032-050
Cylinder Ø
Stroke

M1 M3
Variants from
Standard System

VARIANTS FROM STANDARD SYSTEM:

- R1: Stainless Steel Piston Rod (SS 304-SS 316)
- R4: Stainless Steel Nut for Piston Rod (SS 304)
- R5: Piston Rod as CK45 (Hard Chrome Plated)
- M1: Extended male Piston Rod Thread
- M3: Special Piston Rod Thread
- M4: Extended Piston Rod
- K1: Seals for Max. 150°C (Viton)
- K4: Piston Rod Seal Viton

Force:

Cylinder Ø mm	Rod Ø mm	Thrust and traction forces (6 Bar)	
		Thrust Force (N)	Traction Force (N)
32	12	415	415
40	12	687	687
50	16	1058	1058
63	16	1750	1750
80	20	2829	2829
100	25	4420	4420

Working Fluid:

Filtered and lubricated or filtered and not lubricated air

Operating Temperature Range:

Polyurethane (PU) : (-20°C) - (+80°C)

Viton (FKM) : (-30°C) - (+180°C)

Max. Work Pressure:

10 Bar

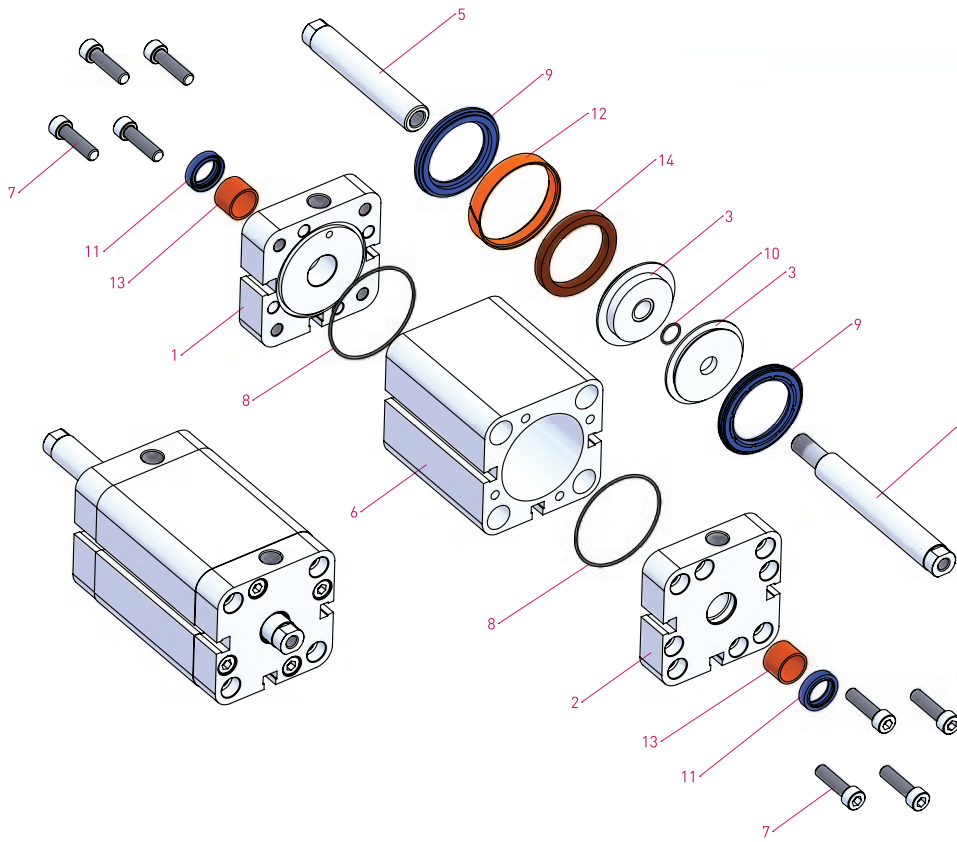
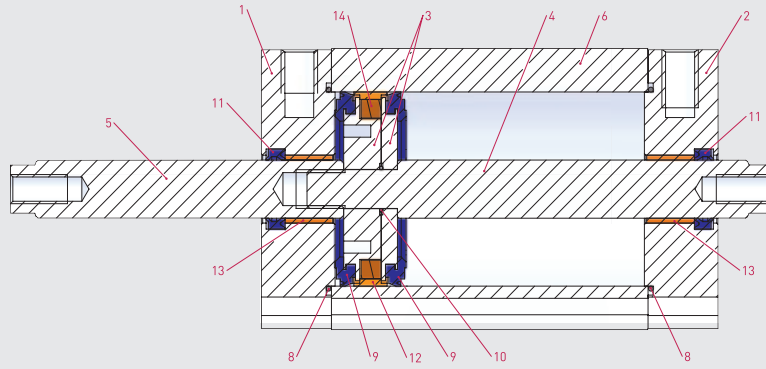

No	MATERIAL NAME	CHARACTERISTIC	PC.
1	Head	Aluminium	1
2	Head	Aluminium	1
3	Middle Piston	Aluminium	2
4	Male Piston Rod	X20 Cr13 Hard Chrome Plated	1
5	Female Piston Rod	X20 Cr13 Hard Chrome Plated	1
6	Tube	Al Mg Si 0,5 + Eloxal Plated	1
7	Bolt	Stainless Steel	8

No	MATERIAL NAME	CHARACTERISTIC	PC.
8	Head O-ring	NBR	2
9	Piston Seal	PU	2
10	Middle Piston O-ring	NBR	1
11	Rod Seal	PU	2
12	Guiding Band	Polyacetal	1
13	Guiding Bush	CSB-40	2
14	Magnet		1



PKD-A SERIES
COMPACT - Ø32 - Ø100

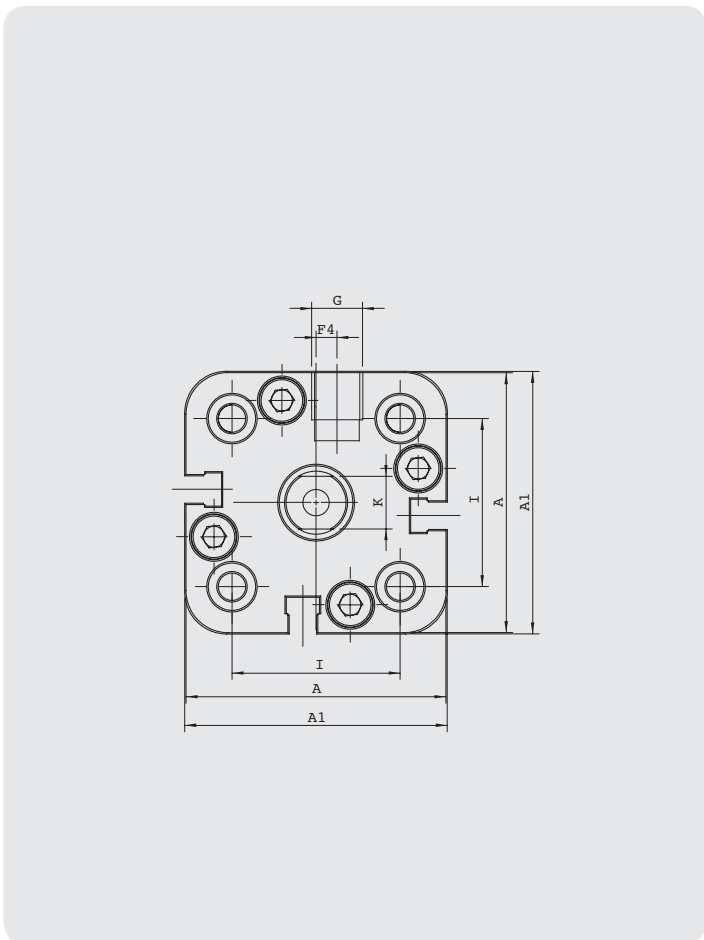
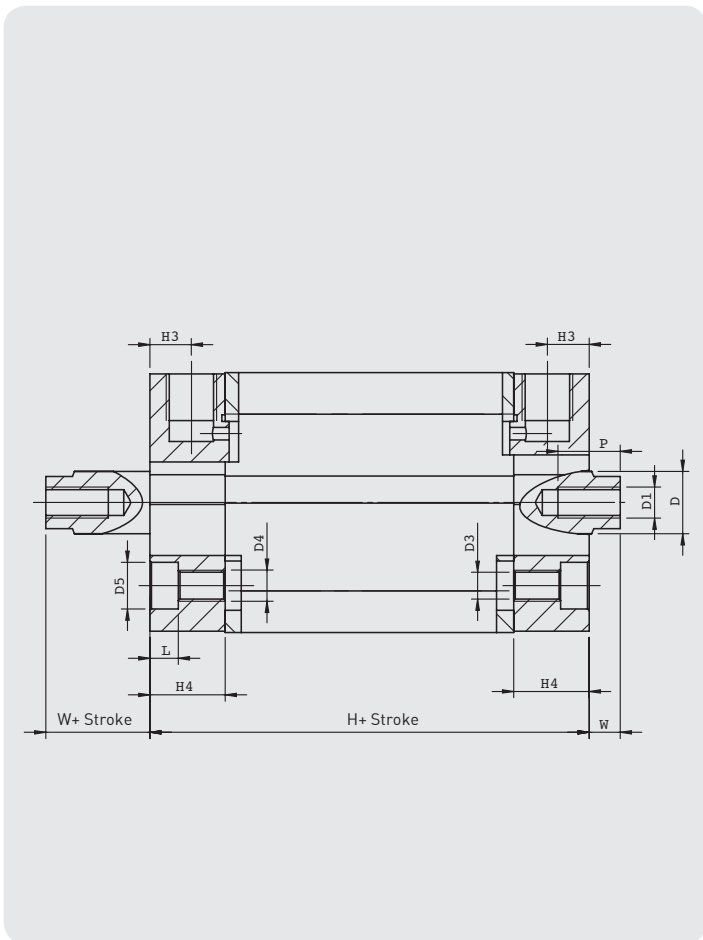

Cylinder Ø mm	A	A1	D Ø	D1 Ø	D2 Ø	D3 Ø	D4 Ø	D5 Ø	F4	G	H	H3	H4	I	K	L	P	W
32	49,5	50	12	M6	6	5,2	M6	9	4	1/8"	44,5	8	14,5	32	10	5,5	12	6
40	57,5	58	12	M6	6	5,2	M6	9	3	1/8"	45,5	8	14,75	42	10	5,5	12	6,5
50	66,5	67	16	M8	6	6,7	M8	10,5	0	1/8"	45,5	8	14,75	50	13	6,5	12	7,5
63	79,5	80	16	M8	8	8,7	M10	13,5	0	1/8"	50	8	14,75	62	13	8,5	14	7,5
80	99,5	100	20	M10	8	8,7	M10	13,5	0	1/8"	56	8,5	16,5	82	17	8,5	15	8
100	123,5	124	25	M12	8	8,7	M10	13,5	0	1/4"	66,5	10,5	19,75	103	22	8,5	20	10

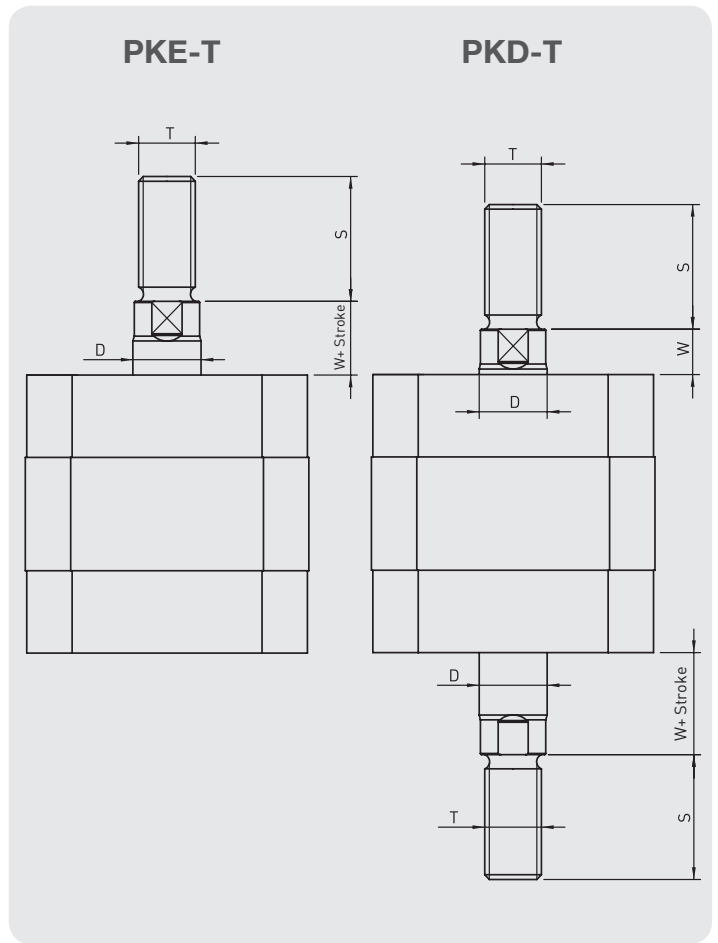
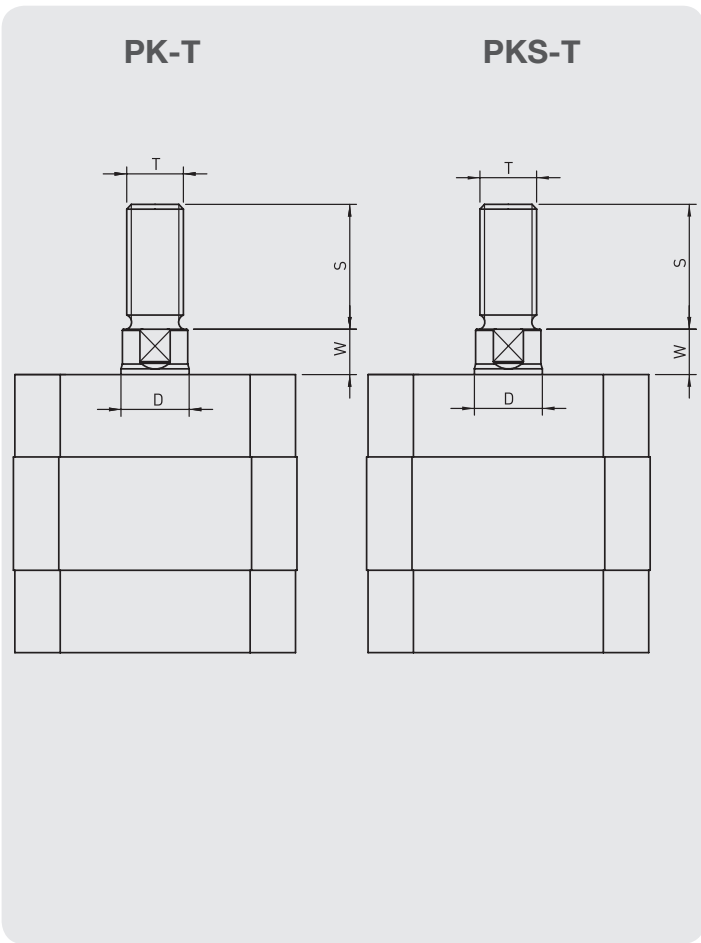
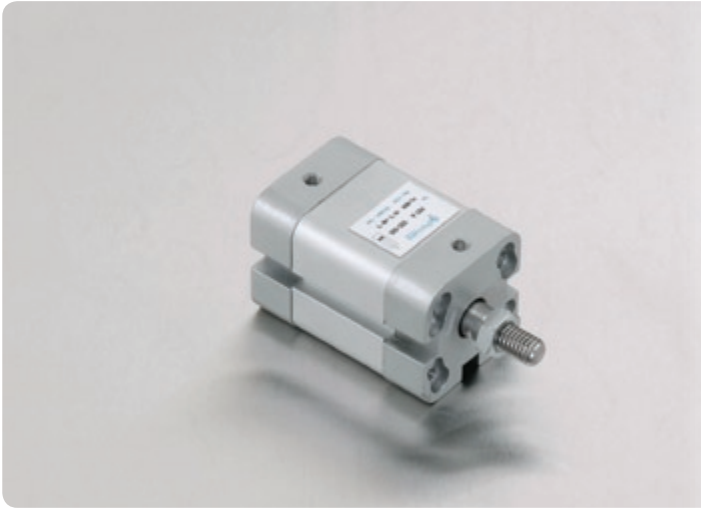

Cylinder type	Cylinder Ø mm	D	S	T	W
	32	12	22	M10x1.25	6
	40	12	22	M10x1.25	6.5
PK-PKS	50	16	24	M12x1.25	7.5
PKE-PKD	63	16	24	M12x1.25	7.5
	80	20	32	M16x1.5	8
	100	25	40	M20x1.5	10

**COMPACT
PNEUMATIC CYLINDERS
PKS-A SERIES Ø32- Ø100**



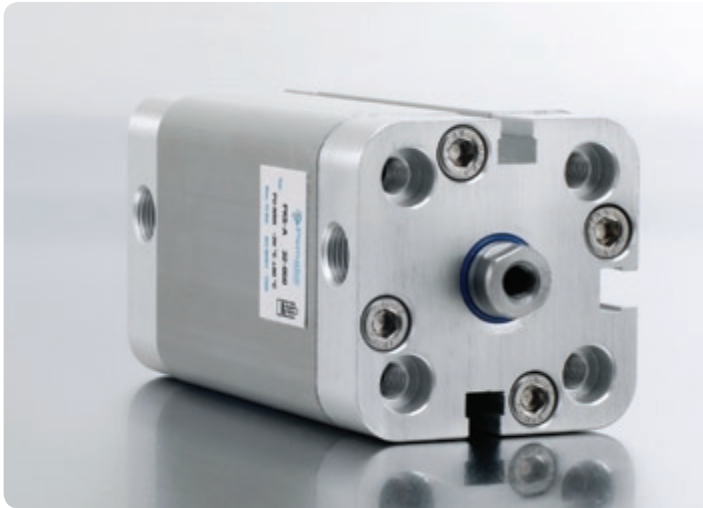

PKS-A SERIES

COMPACT - Ø32 - Ø100

COMPACT CYLINDER
WITH MAGNET AND FRONT SPRING

WITH SINGLE ACTING USAGE
PROVIDES MINIMUM AIR
CONSUMPTION AND EQUIPMENT
COSTS



PKS: COMPACT CYLINDERS WITH
SINGLE ACTING (SPRINGED FROM
FRONT)



PKS-A: MAGNETIC COMPACT
CYLINDERS WITH SINGLE ACTING
(SPRINGED FROM FRONT)

Example of order:

PKS-A
Product Code

032-050
Cylinder Ø
Stroke

M1
Variants from
Standard System

VARIANTS FROM STANDARD SYSTEM:

- R1: Stainless Steel Piston Rod (SS 304-SS 316)
- R4: Stainless Steel Nut for Piston Rod (SS 304)
- R5: Piston Rod as CK45 (Hard Chrome Plated)
- M1: Extended male Piston Rod Thread
- M3: Special Piston Rod Thread
- M4: Extended Piston Rod
- K1: Seals for Max. 150°C (Viton)
- K4: Piston Rod Seal Viton

Force:

Cylinder Ø mm	Rod Ø mm	Thrust and traction forces (6 Bar)	
		Thrust Force (N)	Traction Force (N)
32	12	450	16
40	12	708	23
50	16	1120	30
63	16	1800	35
80	20	2900	60
100	25	4520	100

Working Fluid:

Filtered and lubricated or filtered and not lubricated air

Operating Temperature Range:

Polyurethane (PU) : (-20°C) - (+80°C)

Viton (FKM) : (-30°C) - (+180°C)

Max. Work Pressure:

10 Bar

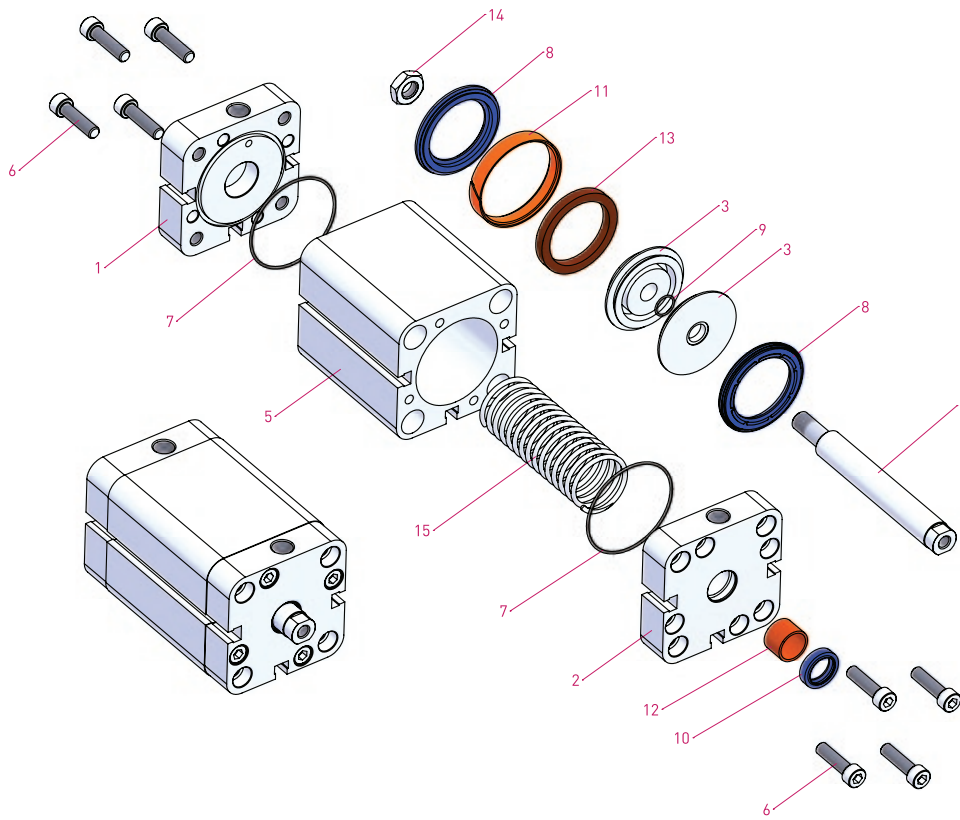
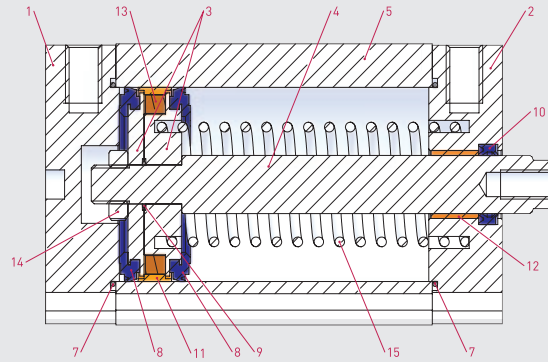

No	MATERIAL NAME	CHARACTERISTIC	PC.
1	Rear Head	Aluminium	1
2	Front Head	Aluminium	1
3	Middle Piston	Aluminium	2
4	Piston Rod	X20 Cr13 Hard Chrome Plated	1
5	Tube	Al Mg Si 0,5 + Eloxac Plated	1
6	Bolt	Stainless Steel	8
7	Head O-ring	NBR	2
8	Piston Seal	PU	2

No	MATERIAL NAME	CHARACTERISTIC	PC.
9	Middle Piston O-ring	NBR	1
10	Rod Seal	PU	1
11	Guiding Band	Polyacetal	1
12	Guiding Bush	CSB-40	1
13	Magnet		1
14	Nut	Galvanized Steel	1
15	Spring	Galvanized Steel	1



PKS-A SERIES
COMPACT - Ø32 - Ø100

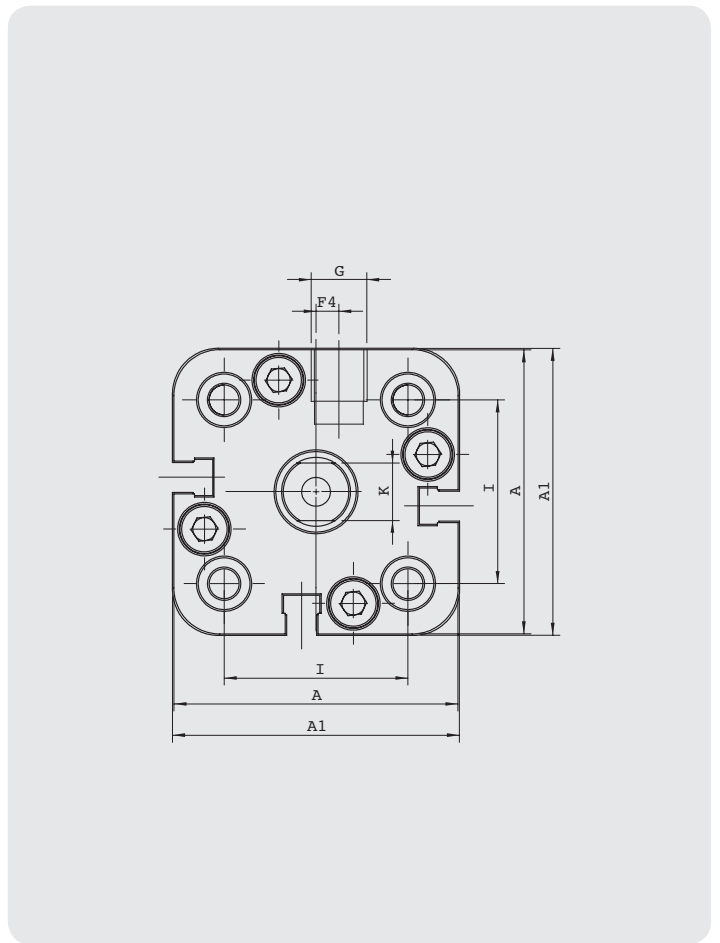
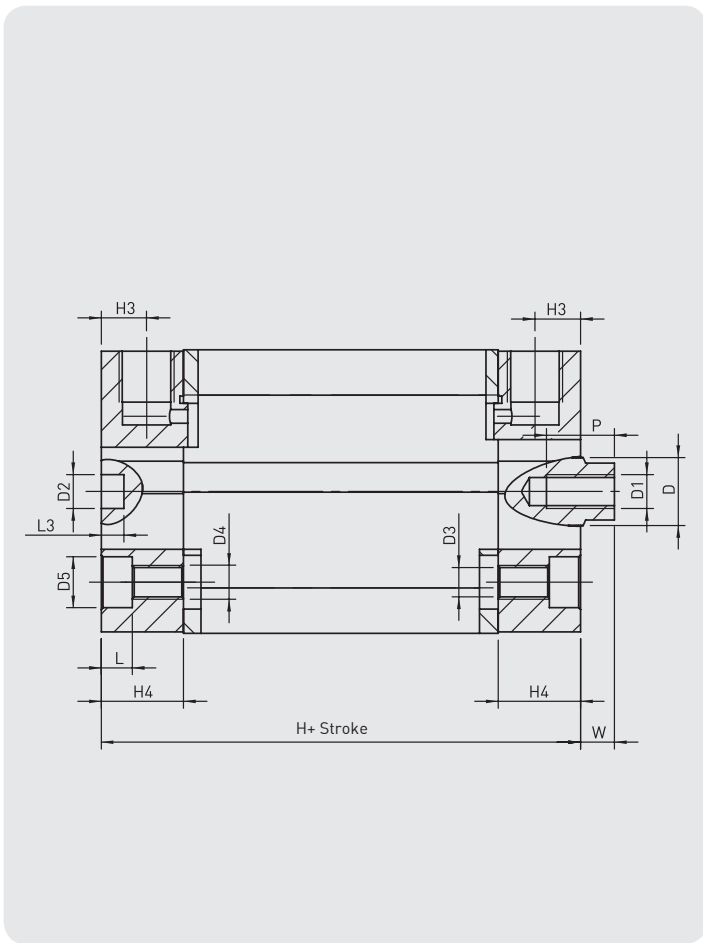

Cylinder Ø mm	A	A1	D Ø	D1 Ø	D2 Ø	D3 Ø	D4 Ø	D5 Ø	F4	G	H	H3	H4	I	K	L	L3	P	W
32	49,5	50	12	M6	6	5,2	M6	9	4	1/8"	44,5	8	14,5	32	10	5,5	4	12	6
40	57,5	58	12	M6	6	5,2	M6	9	3	1/8"	45,5	8	14,75	42	10	5,5	4	12	6,5
50	66,5	67	16	M8	6	6,7	M8	10,5	0	1/8"	45,5	8	14,75	50	13	6,5	4	12	7,5
63	79,5	80	16	M8	8	8,7	M10	13,5	0	1/8"	50	8	14,75	62	13	8,5	4	14	7,5
80	99,5	100	20	M10	8	8,7	M10	13,5	0	1/8"	56	8,5	16,5	82	17	8,5	4	15	8
100	123,5	124	25	M12	8	8,7	M10	13,5	0	1/4"	66,5	10,5	19,75	103	22	8,5	4	20	10



PK-T

PKS-T

PKE-T

PKD-T

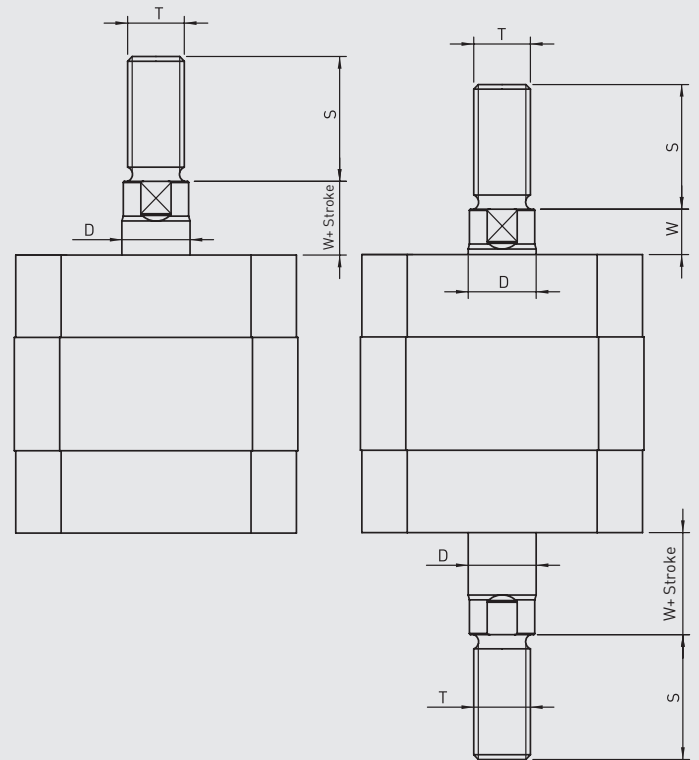
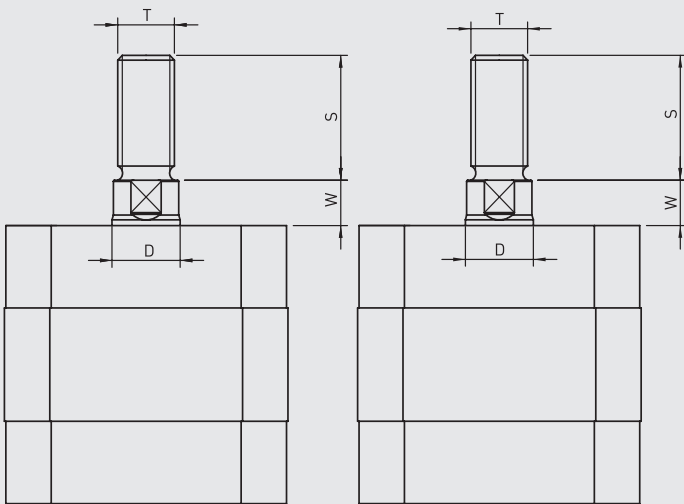

Cylinder type	Cylinder Ø mm	D	S	T	W
	32	12	22	M10x1.25	6
	40	12	22	M10x1.25	6.5
PK-PKS	50	16	24	M12x1.25	7.5
PKE-PKD	63	16	24	M12x1.25	7.5
	80	20	32	M16x1.5	8
	100	25	40	M20x1.5	10

**COMPACT
PNEUMATIC CYLINDERS
PKE-A SERIES Ø32- Ø100**





PKE-A SERIES

COMPACT - Ø32 - Ø100

COMPACT CYLINDER
WITH MAGNET AND REAR SPRING

WITH SINGLE ACTING USAGE
PROVIDES MINIMUM AIR
CONSUMPTION AND EQUIPMENT
COSTS



PKE: COMPACT CYLINDERS WITH
SINGLE ACTING (SPRINGED FROM
BACK)



PKE-A: MAGNETIC COMPACT
CYLINDERS WITH SINGLE ACTING
(SPRINGED FROM BACK)

Example of order:

PKE-A
Product Code

032-025
Cylinder Ø
Stroke

M3
Variants from
Standard System

VARIANTS FROM STANDARD SYSTEM:

- R1: Stainless Steel Piston Rod (SS 304-SS 316)
- R4: Stainless Steel Nut for Piston Rod (SS 304)
- R5: Piston Rod as CK45 (Hard Chrome Plated)
- M1: Extended male Piston Rod Thread
- M3: Special Piston Rod Thread
- M4: Extended Piston Rod
- K1: Seals for Max. 150°C (Viton)
- K4: Piston Rod Seal Viton

Force:

Cylinder Ø mm	Rod Ø mm	Thrust and traction forces (6 Bar)	
		Thrust Force (N)	Traction Force (N)
32	12	16	384
40	12	23	642
50	16	30	1002
63	16	35	1682
80	20	60	2715
100	25	100	4231

Working Fluid:

Filtered and lubricated or filtered and not lubricated air

Operating Temperature Range:

Polyurethane (PU) : (-20°C) - (+80°C)
Viton (FKM) : (-30°C) - (+180°C)

Max. Work Pressure:

10 Bar

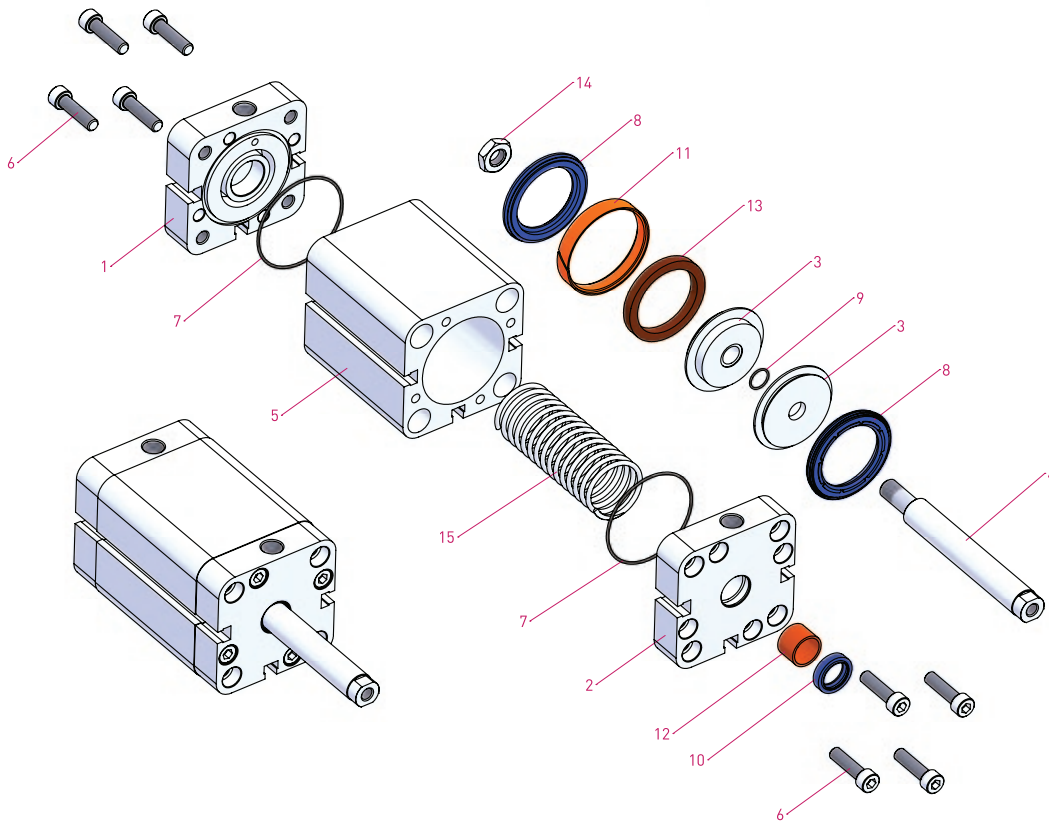
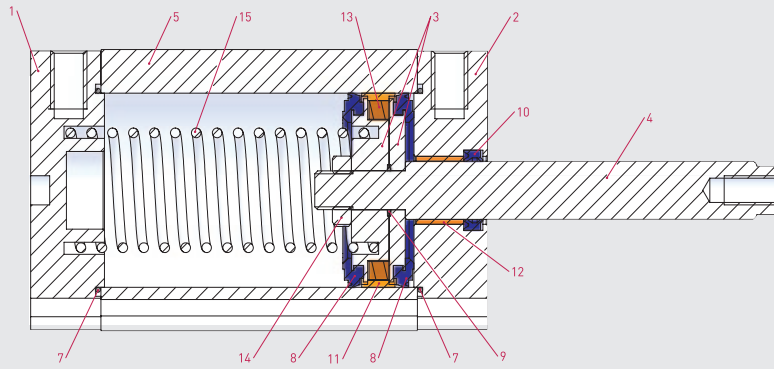

No	MATERIAL NAME	CHARACTERISTIC	PC.
1	Rear Head	Aluminium	1
2	Front Head	Aluminium	1
3	Middle Piston	Aluminium	2
4	Piston Rod	X20 Cr13 Hard Chrome Plated	1
5	Tube	Al Mg Si 0,5 + Eloxal Plated	1
6	Bolt	Stainless Steel	8
7	Head O-ring	NBR	2
8	Piston Seal	PU	2

No	MATERIAL NAME	CHARACTERISTIC	PC.
9	Middle Piston O-ring	NBR	1
10	Rod Seal	PU	1
11	Guiding Band	Polyacetal	1
12	Guiding Bush	CSB-40	1
13	Magnet		1
14	Nut	Galvanized Steel	1
15	Spring	Galvanized Steel	1



PKE-A SERIES
COMPACT - Ø32 - Ø100

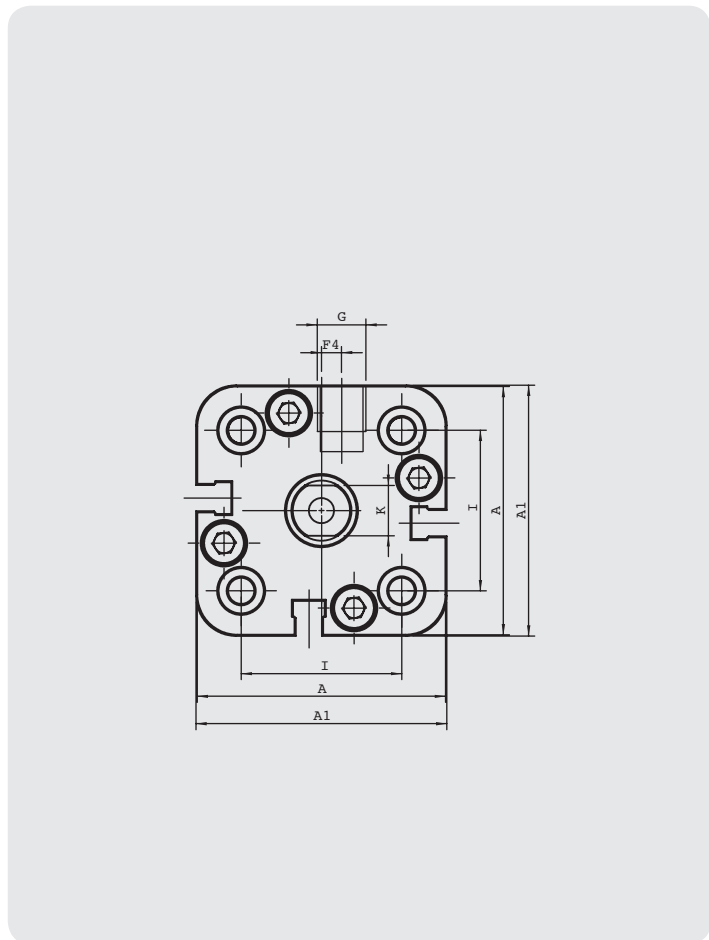
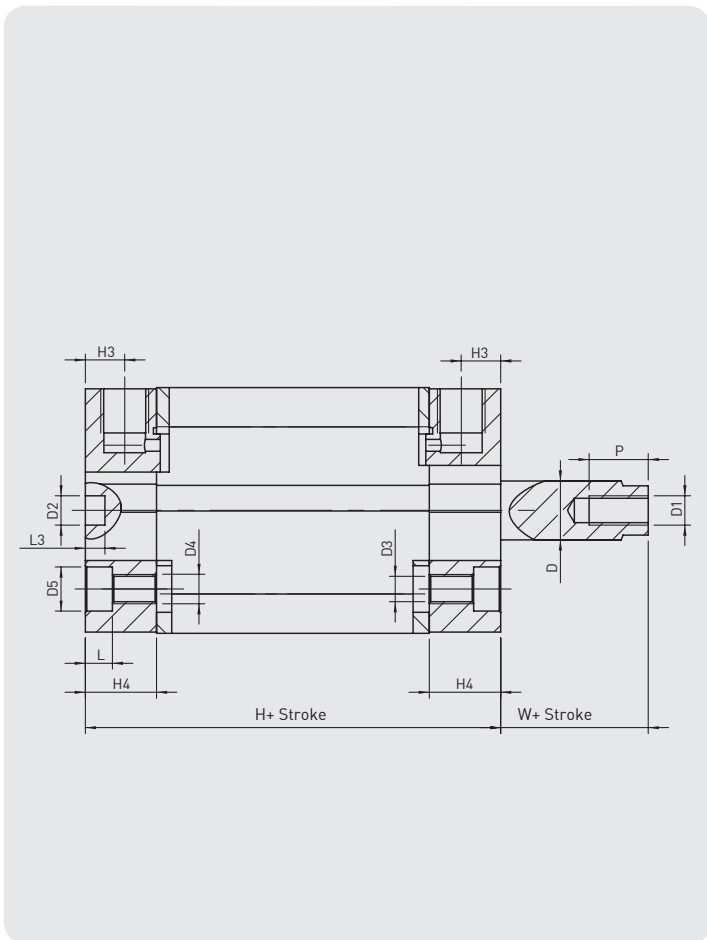

Cylinder Ø mm	A	A1	D Ø	D1 Ø	D2 Ø	D3 Ø	D4 Ø	D5 Ø	F4	G	H	H3	H4	I	K	L	L3	P	W
32	49,5	50	12	M6	6	5,2	M6	9	4	1/8"	44,5	8	14,5	32	10	5,5	4	12	6
40	57,5	58	12	M6	6	5,2	M6	9	3	1/8"	45,5	8	14,75	42	10	5,5	4	12	6,5
50	66,5	67	16	M8	6	6,7	M8	10,5	0	1/8"	45,5	8	14,75	50	13	6,5	4	12	7,5
63	79,5	80	16	M8	8	8,7	M10	13,5	0	1/8"	50	8	14,75	62	13	8,5	4	14	7,5
80	99,5	100	20	M10	8	8,7	M10	13,5	0	1/8"	56	8,5	16,5	82	17	8,5	4	15	8
100	123,5	124	25	M12	8	8,7	M10	13,5	0	1/4"	66,5	10,5	19,75	103	22	8,5	4	20	10

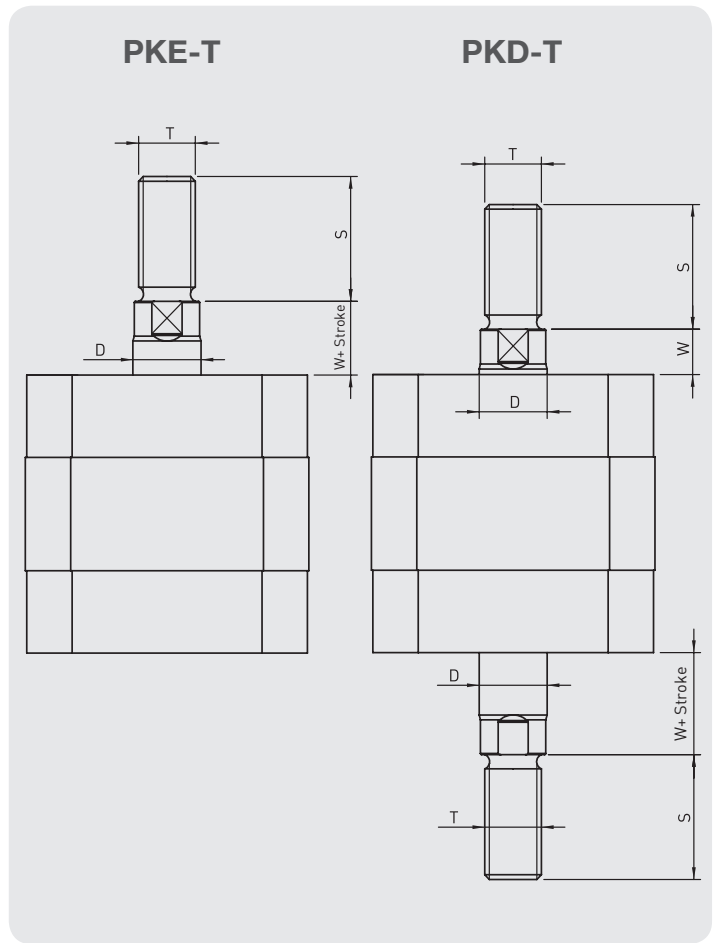
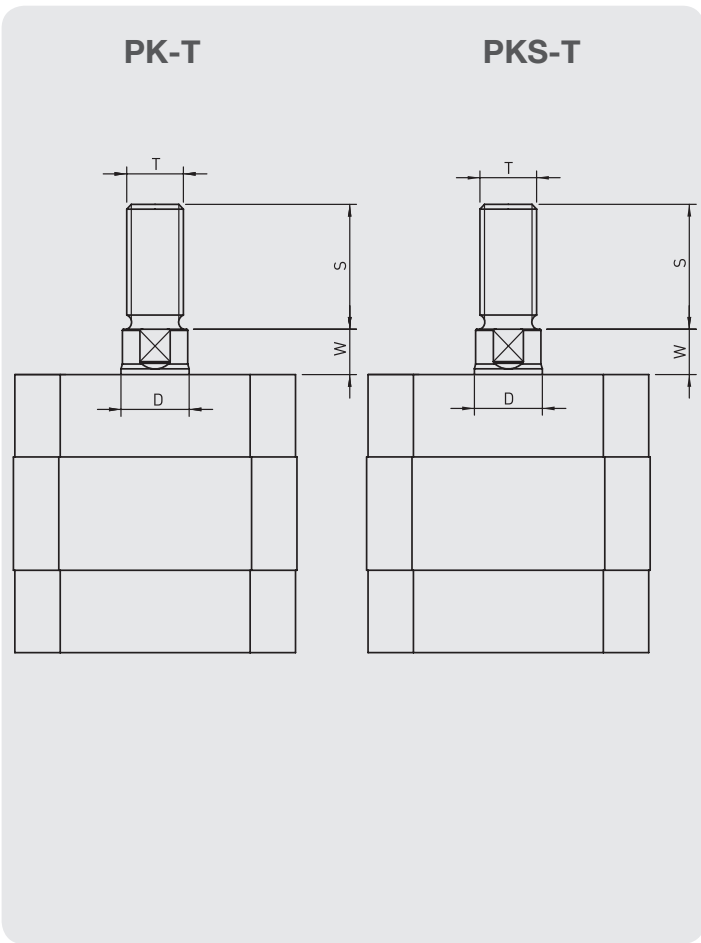

Cylinder type	Cylinder Ø mm	D	S	T	W
	32	12	22	M10x1.25	6
	40	12	22	M10x1.25	6.5
PK-PKS	50	16	24	M12x1.25	7.5
PKE-PKD	63	16	24	M12x1.25	7.5
	80	20	32	M16x1.5	8
	100	25	40	M20x1.5	10

**COMPACT
PNEUMATIC CYLINDERS
PK-A SERIES Ø125- Ø320**

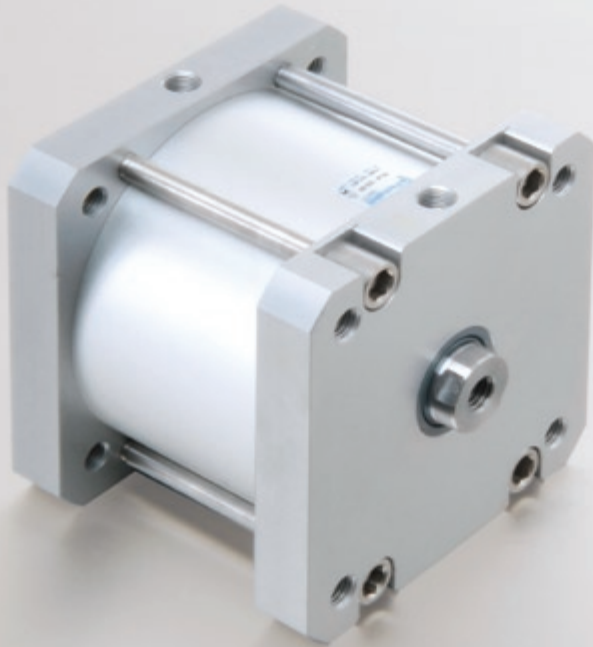



PK-A SERIES

COMPACT - Ø125 - Ø320

COMPACT MAGNETIC CYLINDER

NEED HIGHER POWER IN
A TIGHTER SPACE?
PK-A IS A PERFECT CHOICE.



PK: COMPACT CYLINDERS
WITH DOUBLE ACTING



PK-A: MAGNETIC COMPACT
CYLINDERS WITH DOUBLE ACTING

Example of order:

PK-A
Product Code

125-025
Cylinder Ø
Stroke

K1 M1
Variants from
Standard System

VARIANTS FROM STANDARD SYSTEM:

- R1: Stainless Steel Piston Rod (SS 304-SS 316)
- R4: Stainless Steel Nut for Piston Rod (SS 304)
- M1: Extended male Piston Rod Thread
- M3: Special Piston Rod Thread
- M4: Extended Piston Rod
- K1: Seals for Max. 150° C (Viton)
- K2: Piston Rod Seal NBR + PA
- K4: Piston Rod Seal Viton

Force:

Cylinder Ø mm	Rod Ø mm	Thrust and traction forces (6 Bar)	
		Thrust Force (N)	Traction Force (N)
125	30	7350	6936
160	40	12050	11304
200	40	18840	18086
250	40	29430	28680
320	50	48230	47050

Working Fluid:

Filtered and lubricated or filtered and not lubricated air

Operating Temperature Range:

NBR + Polyurethane (PU): (-20°C) - (+80°C)
Viton (FKM) : (-30°C) - (+180°C)

Max. Work Pressure:

10 Bar

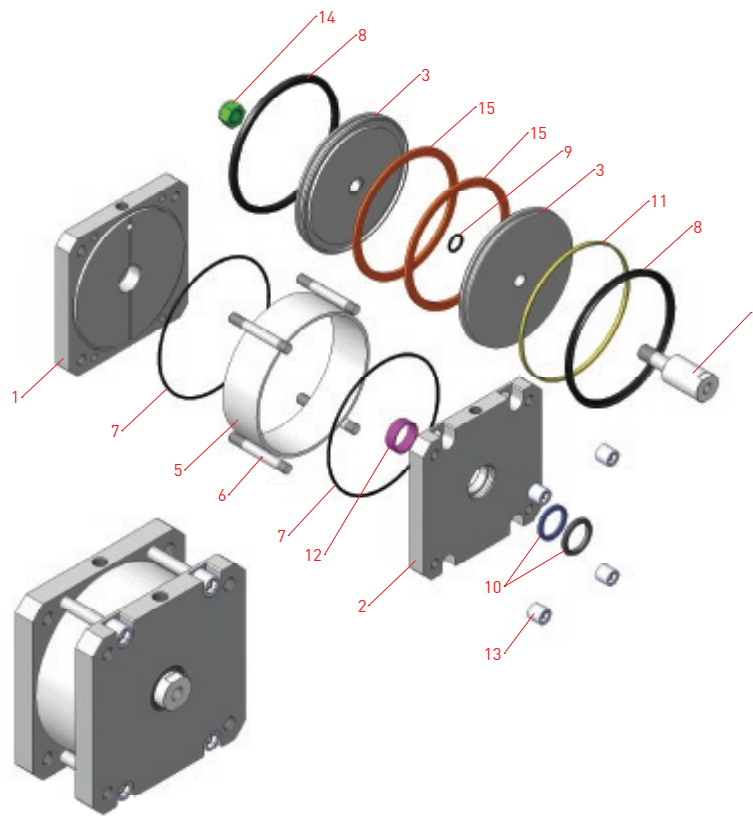
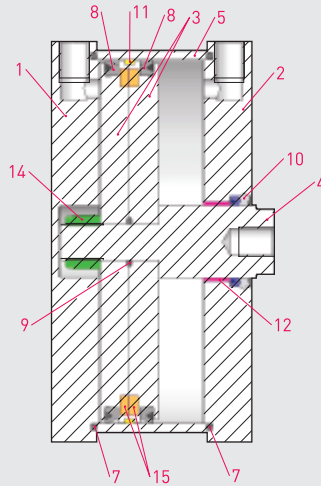

No	MATERIAL NAME	CHARACTERISTIC	PC.
1	Rear Head	Al. + Eloxal Plated	1
2	Front Head	Al. + Eloxal Plated	1
3	Middle Piston	Aluminium	2
4	Piston Rod	CK 45 Hard Chrome Plated	1
5	Tube	Al Mg Si 0,5 + Eloxal Plated	1
6	Tie-Rod	SS 304	4
7	Head O-ring	NBR	2
8	Piston Seal	NBR	2

No	MATERIAL NAME	CHARACTERISTIC	PC.
9	Middle Piston O-ring	NBR	1
10	Rod Seal	PU+Hytrek	1
11	Guiding Band	Carbon Teflon	1
12	Guiding Bush	CSB-40	1
13	Head Nut	SS 304	4
14	Fibre Nut	Galvanized Steel	1
15	Magnet	Ø125-Ø160 Ø200-Ø250-Ø320	1 2



PK-A SERIES
COMPACT - Ø125 - Ø320

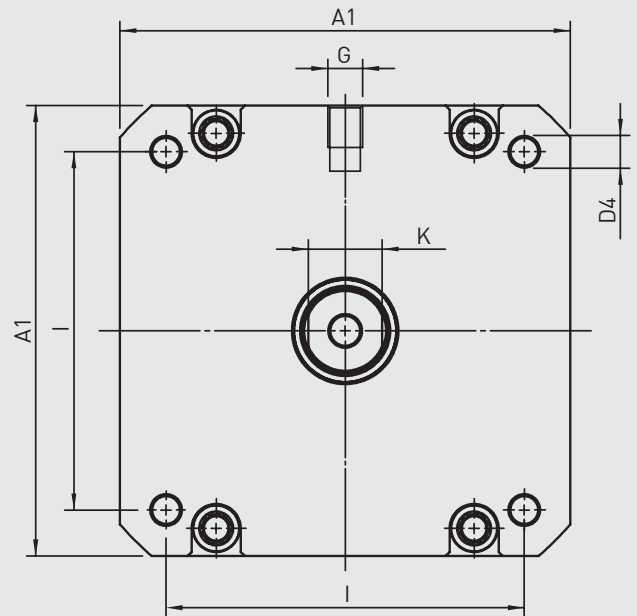
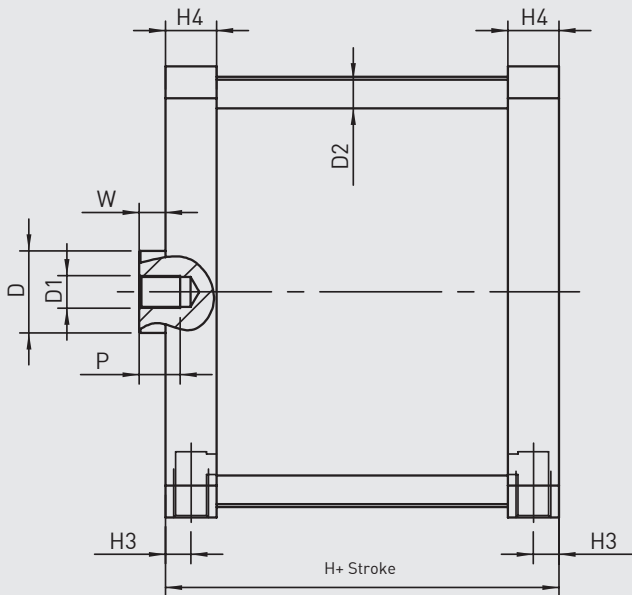

Cylinder Ø mm	A1	D Ø	D1	D2 Ø	D4	G	H	H3	H4	I	K	P	W
125	145	30	M14	10	M12	1/4"	78	10	22	110	27	25	10
160	180	40	M20	12	M16	3/8"	87	12,5	25	140	36	30	12
200	220	40	M20	14	M16	3/8"	87	12,5	25	175	36	30	12
250	270	40	M24	16	M20	1/2"	116	15	33	220	36	35	12
320	340	50	M30	16	M24	1/2"	120	16	34	270	46	40	15

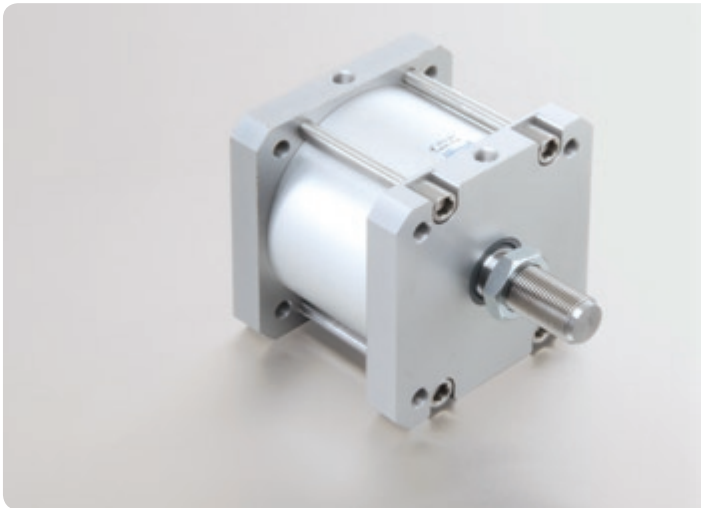

PK-T

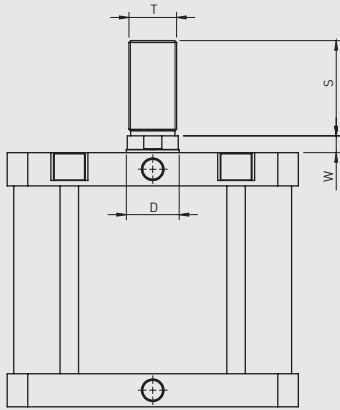

PKD-T

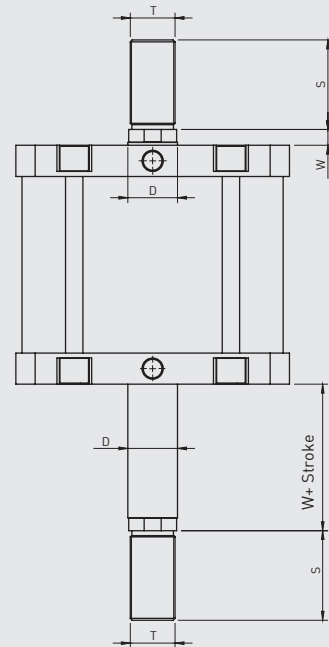

Cylinder type	Cylinder Ø mm	D	S	T	W
	125	30	54	M27x2	10
	160	40	72	M36x2	12
PK-PKD	200	40	72	M36x2	12
	250	40	72	M36x2	12
	320	50	84	M42x2	15

**COMPACT
PNEUMATIC CYLINDERS
PKD-A SERIES Ø125- Ø320**

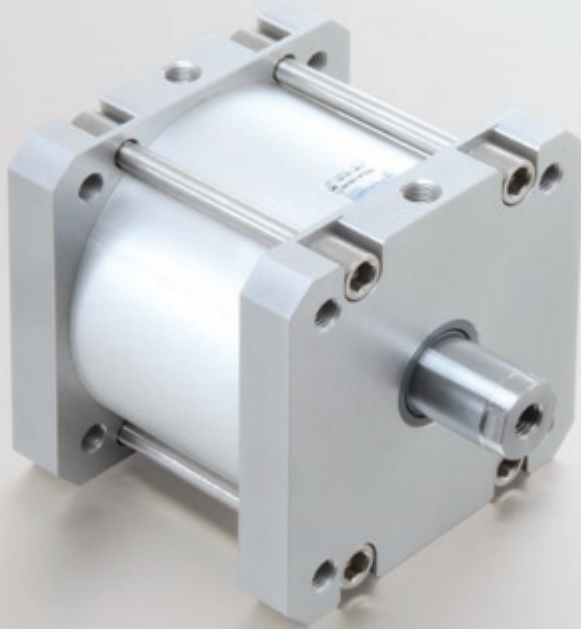



PKD-A SERIES

COMPACT - Ø125 - Ø320

COMPACT, DOUBLE ACTING
CYLINDER WITH MAGNET

POSSIBILITY FOR DOUBLE
DIRECTION RUN WITH IDENTITY
STROKES COMPACT DIMENSIONS

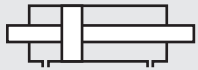

PKD: COMPACT CYLINDERS WITH
DOUBLE ACTING WITH DOUBLE ROD



PKD-A: COMPACT MAGNETIC
CYLINDERS WITH DOUBLE ACTING
WITH DOUBLE ROD

Example of order:

PKD-A
Product Code

125-025
Cylinder Ø
Stroke

M1 M3
Variants from
Standard System

VARIANTS FROM STANDARD SYSTEM:

R1: Stainless Steel Piston Rod (SS 304-SS 316)

R4: Stainless Steel Nut for Piston Rod (SS 304)

M1: Extended male Piston Rod Thread

M3: Special Piston Rod Thread

M4: Extended Piston Rod

K1: Seals for Max. 150° C (Viton)

K2: Piston Rod Seal NBR + PA

K4: Piston Rod Seal Viton

Force:

Cylinder Ø mm	Rod Ø mm	Thrust and traction forces (6 Bar)	
		Thrust Force (N)	Traction Force (N)
125	30	6936	6936
160	40	11304	11304
200	40	18086	18086
250	40	28680	28680
320	50	47050	47050

Working Fluid:

Filtered and lubricated or filtered and not lubricated air

Operating Temperature Range:

NBR + Polyurethane (PU): (-20°C) - (+80°C)

Viton (FKM) : (-30°C) - (+180°C)

Max. Work Pressure:

10 Bar

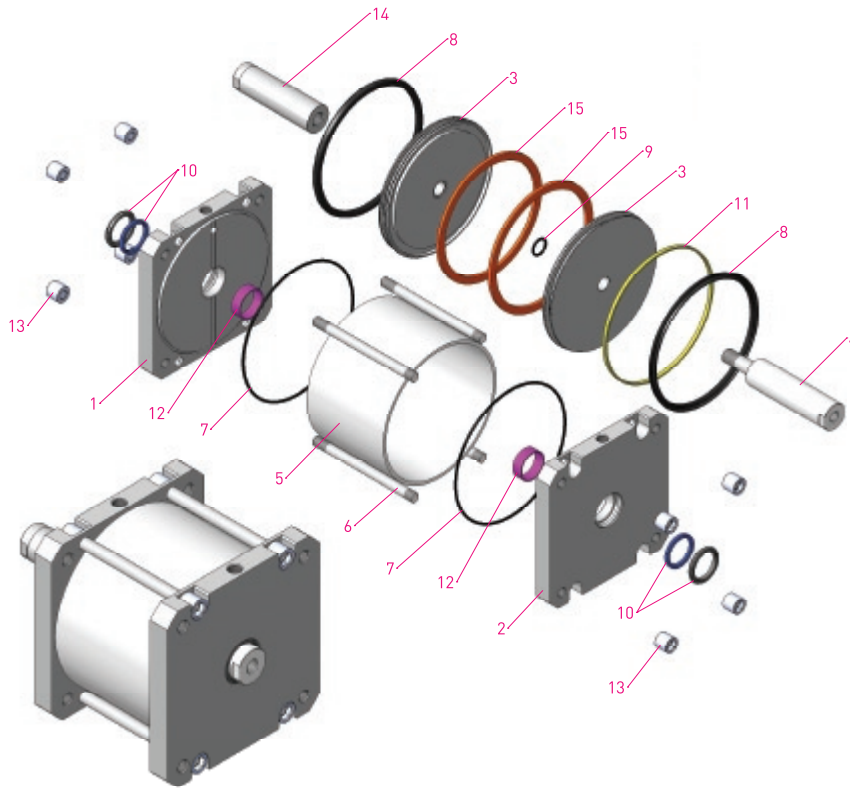
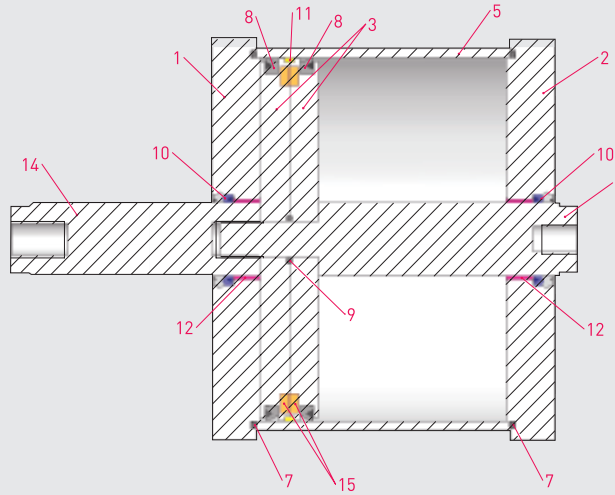

No	MATERIAL NAME	CHARACTERISTIC	PC.
1	Front Head	Al. + Eloxal Plated	1
2	Front Head	Al. + Eloxal Plated	1
3	Middle Piston	Aluminium	2
4	Male Piston Rod	CK 45 Hard Chrome Plated	1
5	Tube	Al Mg Si 0,5+Eloxal Plated	1
6	Tie-Rod	SS 304	4
7	Head O-ring	NBR	2
8	Piston Seal	NBR	2

No	MATERIAL NAME	CHARACTERISTIC	PC.
9	Middle Piston O-ring	NBR	1
10	Rod Seal	PU+Hytrell	2
11	Guiding Band	Carbon Teflon	1
12	Guiding Bush	CSB-40	2
13	Head Nut	SS 304	8
14	Female Piston Rod	CK 45 Hard Chrome Plated	1
15	Magnet	Ø125-Ø160 Ø200-Ø250-Ø320	1 2

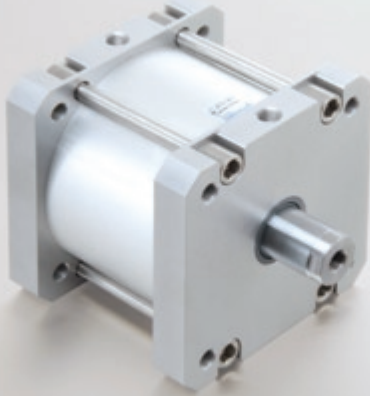

PKD-A SERIES
COMPACT - Ø125 - Ø320

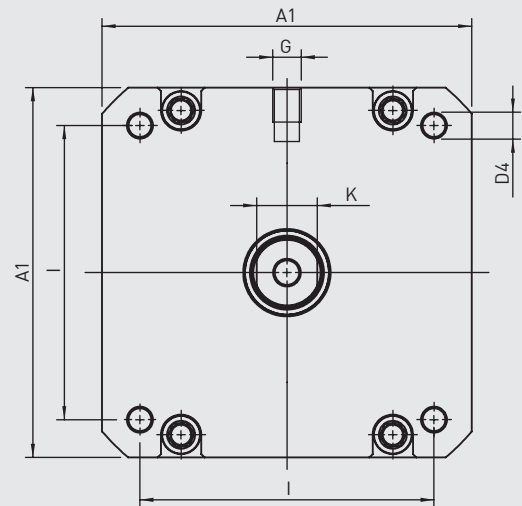
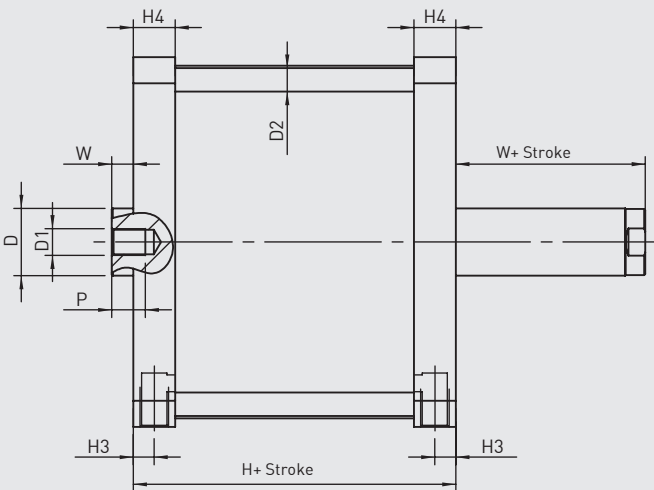

Cylinder Ø mm	A1	D Ø	D1	D2 Ø	D4	G	H	H3	H4	I	K	P	W
125	145	30	M14	10	M12	1/4"	78	10	22	110	27	25	10
160	180	40	M20	12	M16	3/8"	87	12,5	25	140	36	30	12
200	220	40	M20	14	M16	3/8"	87	12,5	25	175	36	30	12
250	270	40	M24	16	M20	1/2"	116	15	33	220	36	35	12
320	340	50	M30	16	M24	1/2"	120	16	34	270	46	40	15

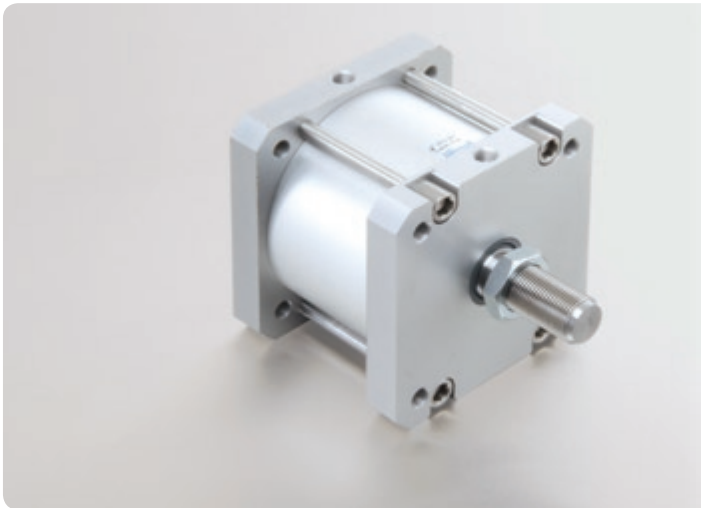

PK-T

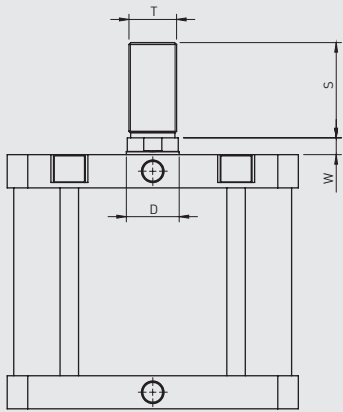

PKD-T

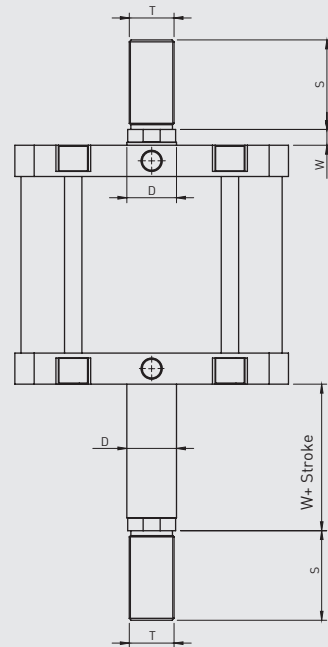

Cylinder type	Cylinder Ø mm	D	S	T	W
	125	30	54	M27x2	10
	160	40	72	M36x2	12
PK-PKD	200	40	72	M36x2	12
	250	40	72	M36x2	12
	320	50	84	M42x2	15

RODLESS CYLINDERS

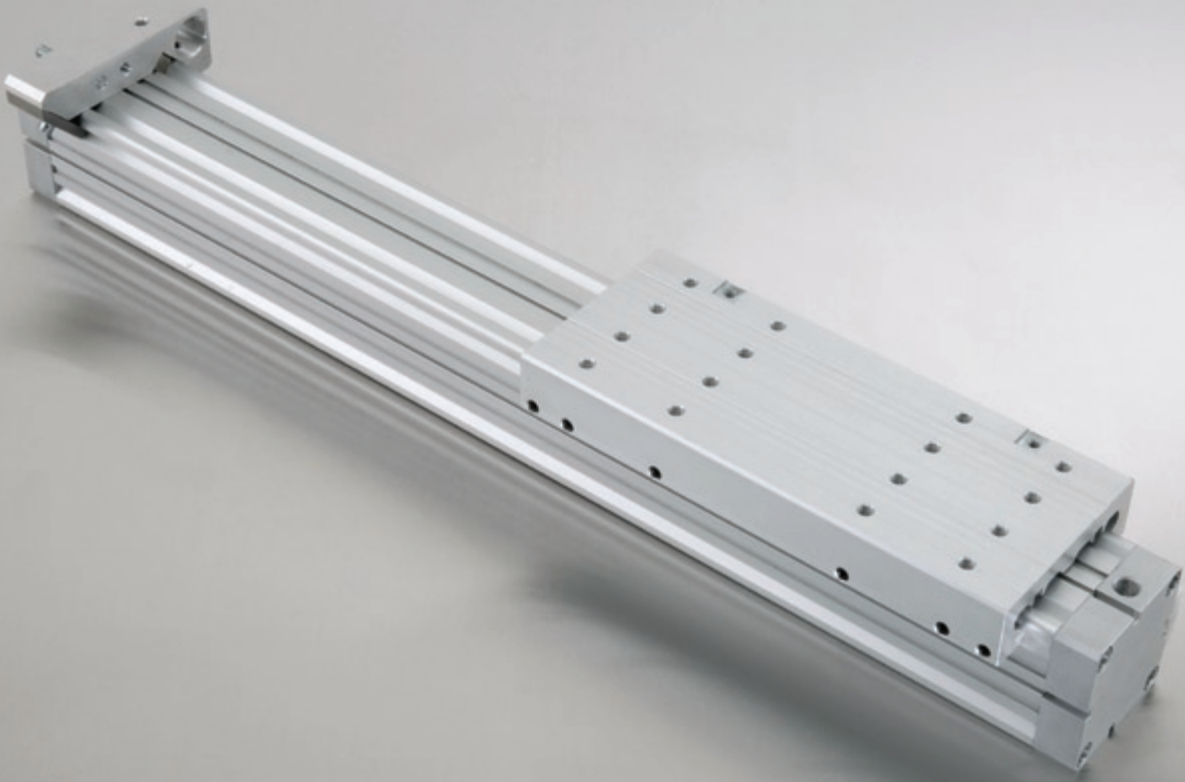

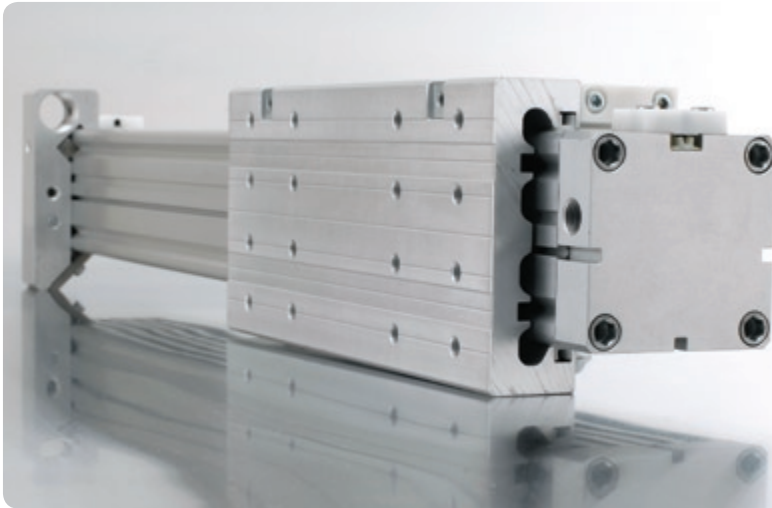

RODLESS CYLINDERS

Ø18 - Ø63

SPECIAL DESIGN FOR SAVING SPACE



SAFETY REGULATIONS

The LANAMATIC cylinder is safe and made according to the latest technical research.

There could be a danger if

- The cylinder will be used, mounted and maintained either improperly or by unqualified staff

- The cylinder will not be used according to the regulations.
- The accident prevention regulations (UUV, VDE), the safety and installation regulations will not be respected

- Working methods, restricting the function and operation safety of the cylinder, have to be omitted.

- The cylinder is exclusively to be used in the scope of its technical data; any other use beyond this is out of the regulations

- The manufacturer is not liable for damages caused by such an improper use.

- In case of mounting, rebuilding or maintaining the energy supply has to be removed.

- In case of maintenance, extension or rebuilding it is advisable to remove the cylinder from the working area and to do the work out of the danger zone.

- When mounting, connecting, adjusting, bringing into service and testing the units it should be guaranteed that no mechanic or another person could operate the cylinders by mistake.

- Additional bores, thread or attachments, being not offered as accessories, can only be applied after consulting the LANAMATIC AG.

- Should a cylinder be operated in the neighbourhood of abrasive dust or aggressive vapour, the prior approval of LANAMATIC AG is necessary.

- Otherwise, the safety and accident prevention regulations of the operation place are valid.

Note:

These data are to be used as product information and not as granted properties by law.

Any claim for damages against us is to be ruled out, without considering the cause in law, unless intention or gross negligence could be applied to us.

All rights reserved for technical changes, omissions and fallacy.



ZS
ZSS **STANDARD CYLINDER**
With identical fitting length as existing cylinders without piston 0-stroke compatible.



ZK
ZKS **SHORT CYLINDER**
With extremely shortened fitting length 0-stroke up to %42 shorter.



ZF
ZFF
ZFK
ZFU
ZFB **GUIDING CYLINDER**
With external an adjustable slide guide. For high Loads.



ZP **PARALLEL CYLINDER**
for high loads and moments in every direction double action force central port.



ZGS
ZGK
ZGF
ZGFK **GRIPPING CYLINDER**
Gripping and clamping functions. Opening & closing functions.



ZTS
ZTK
ZTF **TANDEM CYLINDER**
For high moments in longitudinal direction.



ZDS
ZDK
ZDF
ZDFK **DOUBLE ACTION CYLINDER**
Double action force pressing, embossing, punching etc.



FB
MB
PB
KT **ACCESSORIES**
Mounting brackets. Middle support. Swinging bridge. Cross support etc.

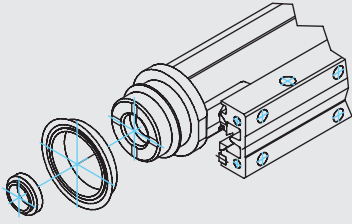

Lubricate piston seals and cushioning ring lightly.
Mount piston seals on piston.
Put cushioning ring into the slot.
Take care that the smaller Ø of the ring is out side.

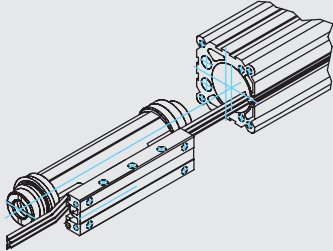

Lubricate sealing strip lightly.
Bend up one end and insert it into yoke.
Insert long end of sealing strip into the tube profile and put the yoke into the tube profile.

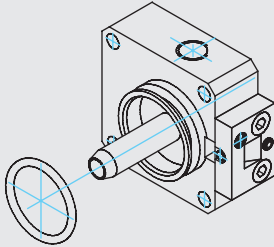

Endcap is preassembled with strip cover and cushioning pin.
Lubricate O-ring and mount it.

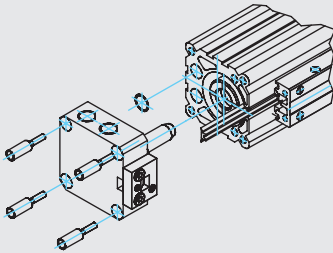

Push yoke to the end and insert end cap.
On one side port insert flat sealing and tighten the special screws.

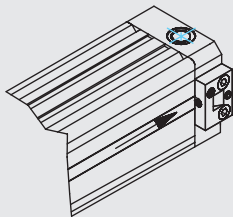

Insert cover strip and clamp it with grub screw.
Pull through yoke.
Measure exact length and clamp it on other side.

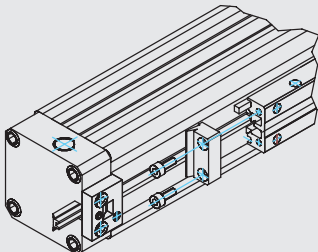

Pull the sealing strip tight (approx 0.5 - 1% of the length), stretch it and fix with grub screw with pin.
Cut off overstanding sealing strip insert wiper, screw on head wiper and tighten cover strip with it

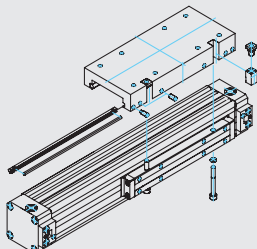

Fit grub screw with adhesive (Loctite).
Slide on guide carriage and adjust guiding bar with grub screws lightly.
Beat guide carriage lightly with a rubber hammer from the side.
Check clearance, readjust if necessary

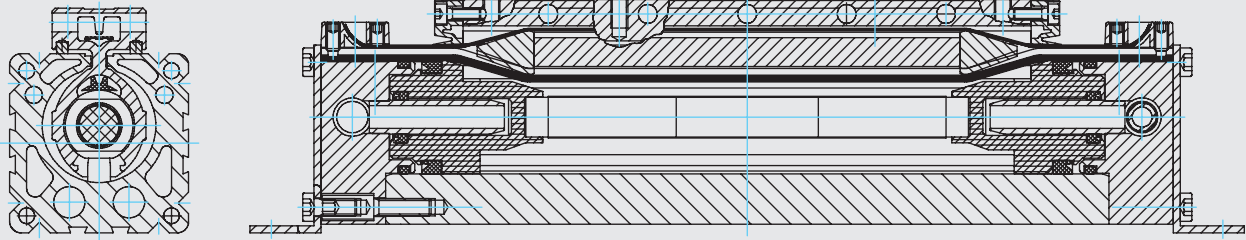

TECHNICAL INFORMATION

Construction	: Rodless cylinder with direct power transmission through the tube slot onto the yoke
Stroke	: Variable up to 6000 mm higher on request.
Fitting position	: Variable.
Operation	: Double acting with adjustable end of travel cushioning.
Operating pressure	: 2 - 8 bar
Operating temperature	: -20° C / +80° C
Medium	: Filtered and slightly oiled or not lubricated compressed air.
Material	: Aluminium parts made of high-strength alloy, sealing parts made of oil resistant plastic and elastomers

Cylinder	Force/6 bar	Cushioning	Weight			Weight/Stroke
			ZS	ZF	ZFF	
18	140 N	15 mm	0.3 kg	0.4 kg	0.6 kg	1.5 kg/1000 mm
25	270 N	18 mm	0.6 kg	0.9 kg	1.1 kg	2.6 kg/1000 mm
32	440 N	24 mm	1.1 kg	1.5 kg	2.2 kg	3.6 kg/1000 mm
40	680 N	34 mm	1.8 kg	2.8 kg	3.8 kg	4.8 kg/1000 mm
50	1060 N	40 mm	3.2 kg	4.9 kg	6.4 kg	7.4 kg/1000 mm
63	1680 N	49 mm	5.6 kg	8.0 kg	10.4 kg	10.0 kg/1000 mm

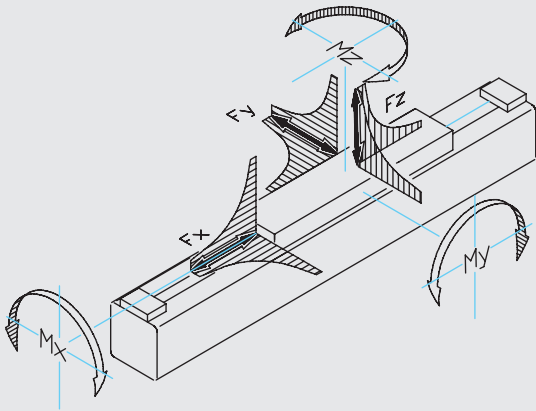

LOADS

All data concerning ile forces and torques refer to a speed of $v < 0.35$ m/s

Observation keeping the indicated values ensures maximum service life, minimum noise and optimum operating results.

Higer speeds reduce the admissible forces.

ZS STANDARD CYLINDER

Cylinder	V max ≤ 0.35 m/s			V or port F			Torques		
	Fx (N)	Fy (N)	Fz (N)	F 0.75 m/s	F 1 m/s	F 1.5 m/s	Mx (Nm) Fy/Fz	My (Nm) Fx/Fz	Mz(Nm) Fx/Fy
18	140	80	300	80	40	20	1	3	3
25	270	110	480	155	90	40	2	13	13
32	440	165	650	280	155	70	3.5	25	25
40	680	225	800	500	290	125	5.5	40	40
50	1060	325	1060	790	420	195	10	65	65
63	1680	435	1680	1500	850	370	16	100	100

ZF GUIDING CYLINDER

Cylinder	V max ≤ 0.35 m/s			V or port F			Torques		
	Fx (N)	Fy (N)	Fz (N)	F 0.75 m/s	F 1 m/s	F 1.5 m/s	Mx (Nm) Fy/Fz	My (Nm) Fx/Fz	Mz(Nm) Fx/Fy
18	140	370	370	100	58	26	3.5	6	6
25	270	800	800	280	160	65	10	20	20
32	440	1200	1200	510	300	140	25	45	45
40	680	1600	1600	1000	550	250	40	75	75
50	1060	2100	2100	1500	850	380	80	150	150
63	1680	2800	2800	2500	1400	610	110	250	250

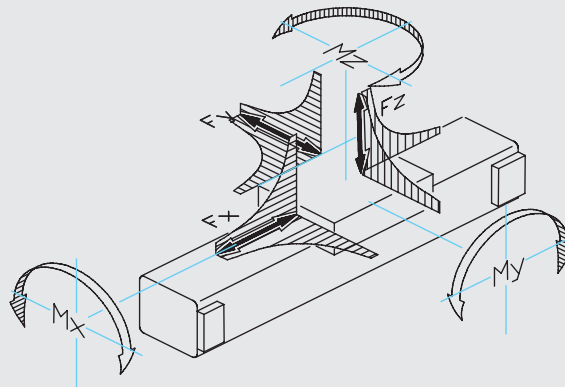
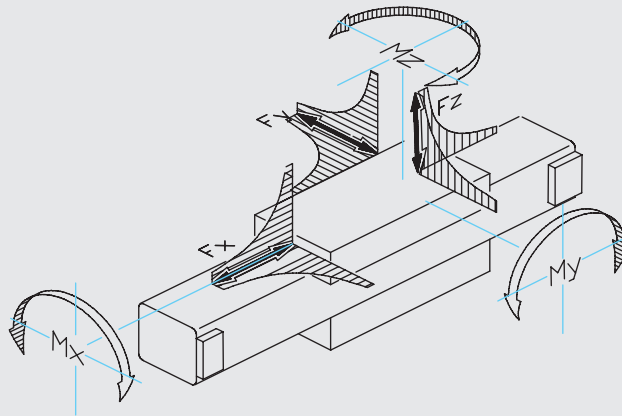

ZFF DOUBLE GUIDING CYLINDER

Cylinder	V max \leq 0.35 m/s			V or port F			Torques		
	Fx (N)	Fy (N)	Fz (N)	F 0.75 m/s	F 1 m/s	F 1.5 m/s	Mx (Nm) Fy/Fz	My (Nm) Fx/Fz	Mz(Nm) Fx/Fy
18	140	550	550	150	80	31	5.2	9	9
25	270	1200	1200	420	210	80	15	30	30
32	440	1800	1800	750	400	170	37	67	67
40	680	2400	2400	1500	750	300	60	110	110
50	1060	3200	3200	2200	1150	460	120	220	220
63	1680	4200	4200	3700	1900	740	170	370	370

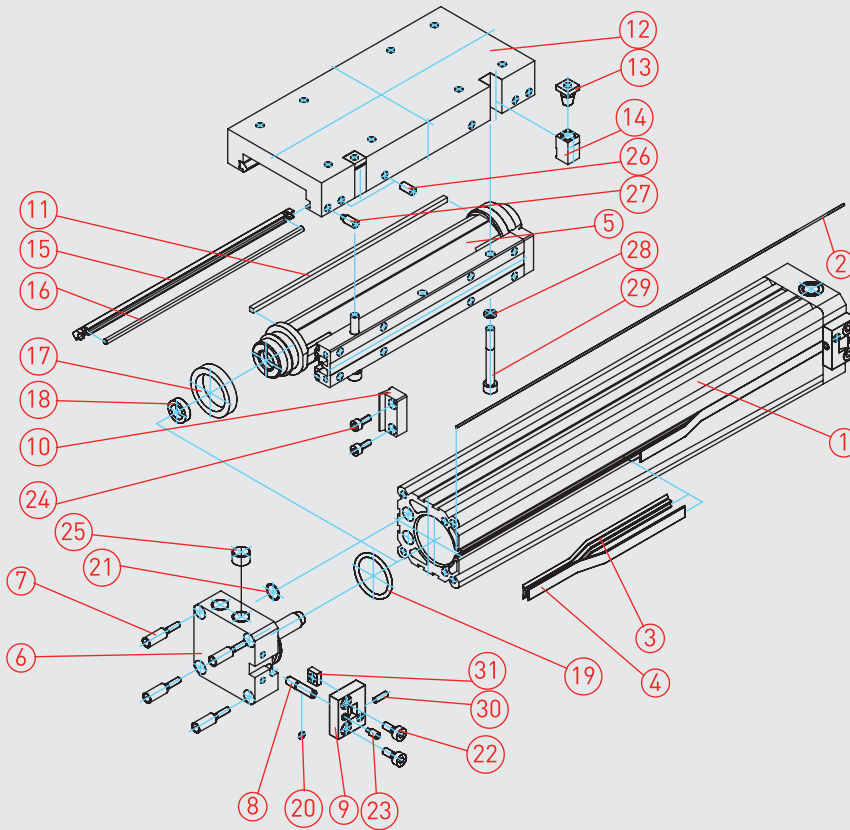
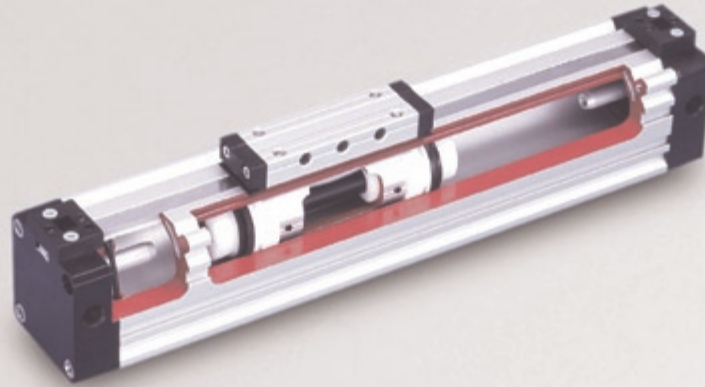

No	MATERIAL NAME	CHARACTERISTIC
1	Tube	Al Mg Si 0.5 Eloval Plated
2	Rond Profile	TPU
3	Sealing Strip	PA
4	Cover Strip	Stainless Steel
5	Yoke	Al Eloval / POM
6	Endcap	Al Eloval
7	Special Screw	Zinc-Plated Steel
8	Cushioning Pin	Stainless Steel
9	Strip Cover	POM
10	Head Wiper	POM
11	Wiper	POM
12	Carriage	Al Eloval
13	Cone Nut	Zinc-Plated Steel
14	Clamp Wedge	Al Eloval
15	Guiding Bar	POM
16	Press Bar	Stainless Steel

No	MATERIAL NAME	CHARACTERISTIC
17	Piston Seal	PU
18	Cushion Ring	NBR
19	O-ring	NBR
20	O-ring	NBR
21	Flat Seal	NBR
22	Countersunk Screw	Zinc-Plated Steel
23	Grup Screw with Pin	Zinc-Plated Steel
24	Cylinder Head Screw	Zinc-Plated Steel
25	Plug Screw	Zinc-Plated Steel
26	Grub Screw	Stell
27	Grub Screw with Pin	Stell
28	Plain Washer	Zinc-Plated Steel
29	Cylinder Head Screw	Zinc-Plated Steel
30	Grub Screw	Stell
31	Square Nut	Zinc-Plated Steel

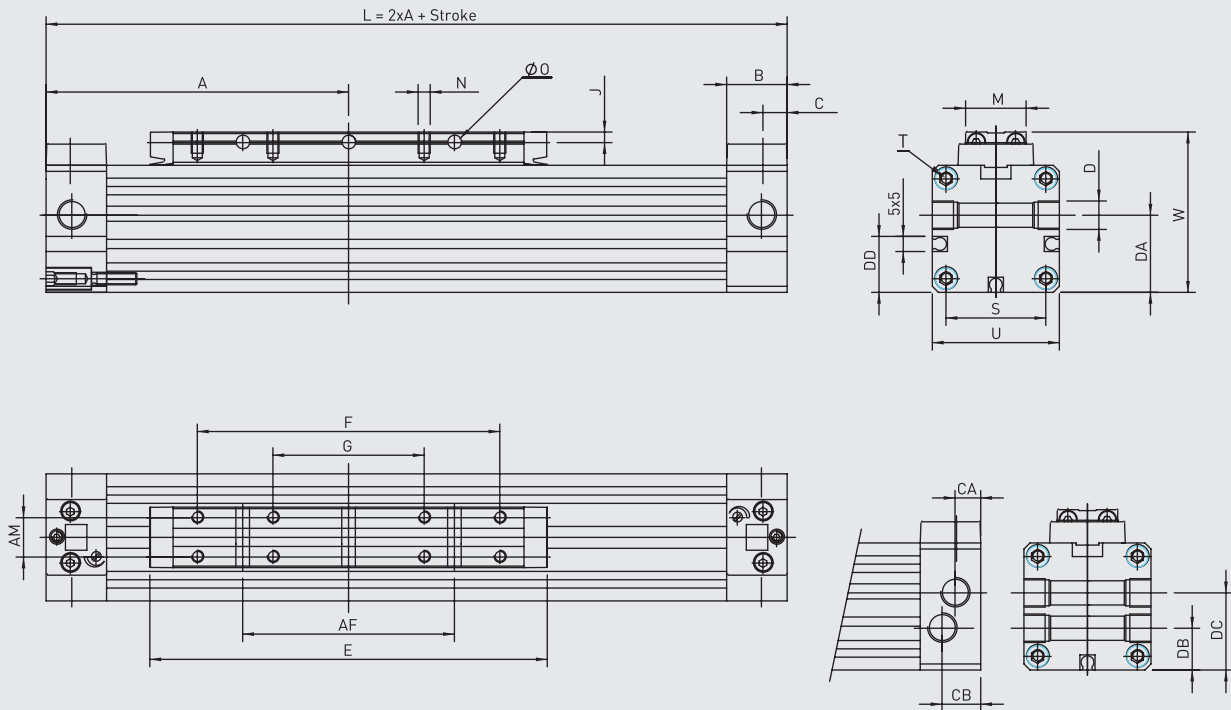

ZS STANDARD CYLINDER

\varnothing	A	AF	AM	B	C	CA	CB	D	DA	DB	DC	DD	E	F	G	J	M	N	$\varnothing O$	S	T	U	W
$\varnothing 18$	80	50	10	16.5	6.5	-	-	M7x1/6	15.5	-	-	-	103	75	-	3	15.5	M3x6	$\varnothing 3.5$	23.5	M3x7	30	39
$\varnothing 25$	100	70	13	20	8.5	7	13	G1/8x8	25.5	14	28	18.5	131	100	50	3.5	20	M4x7	$\varnothing 4.5$	33	M4x9	42	53
$\varnothing 32$	120	100	16	20	8.5	7	13	G1/8x8	32	16	34.5	21	171	140	70	4.5	25	M5x9	$\varnothing 5.5$	41	M5x10	52	65
$\varnothing 40$	150	140	22	23	13	11	14.5	G1/4x12	37.5	18.5	41	29.5	220	180	90	5	33	M6x10	$\varnothing 7$	51	M6x12	63	79
$\varnothing 50$	180	180	29	23	13	12	14	G1/4x12	47.5	22.5	47.5	37	280	220	110	6.5	42	M8x12.5	$\varnothing 7$	63	M8x12	78	96
$\varnothing 63$	215	230	40	29	13	12.5	15.5	G3/8x12	59.5	24.5	59.5	44.5	333	280	140	8	54	M8x15	$\varnothing 9$	78	M8x12	93	113.5

Example of order: ZS $\varnothing 25$ Standard cylinder with stroke 100mm

Order number															
1	2	5	0	-	0	0	0	0	0	-	0	1	0	0	Port Standard
1	2	5	0	-	0	0	0	1	-	0	1	0	0	0	Port Underneath
1	2	5	0	-	0	0	0	2	-	0	1	0	0	0	One Side Port

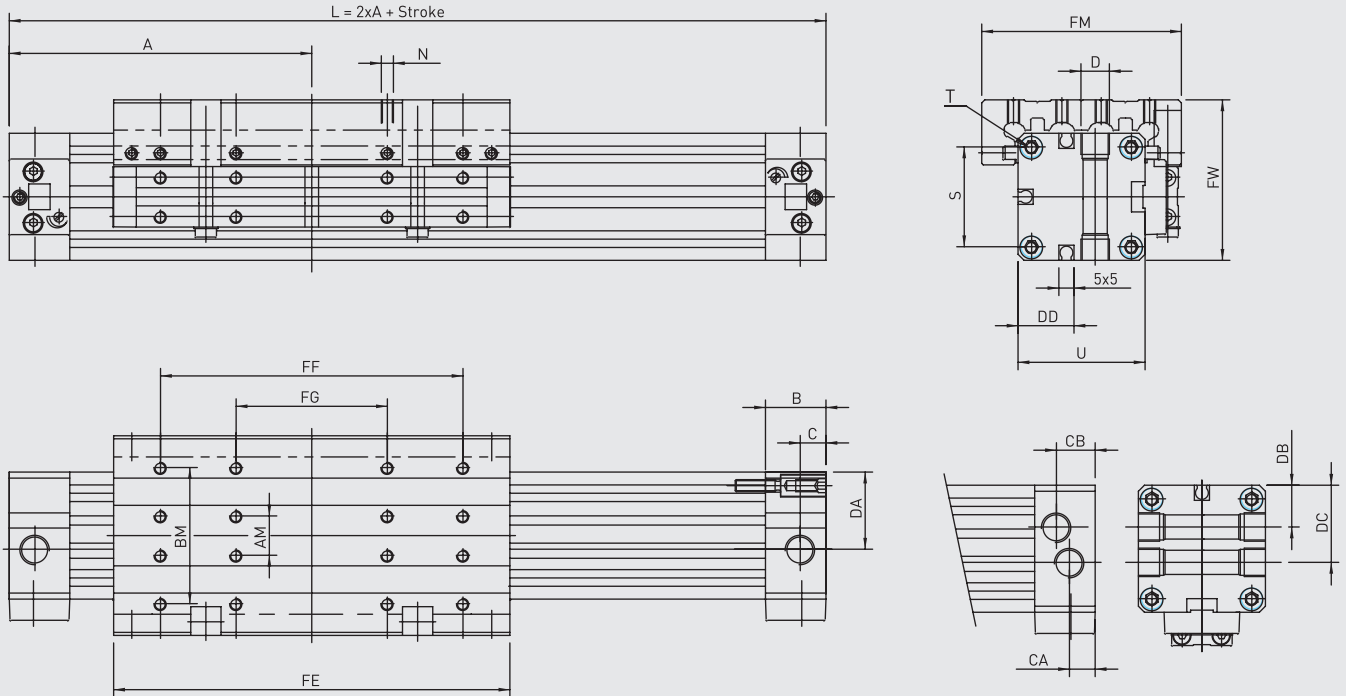

ZF GUIDING CYLINDER

Ø	A	AM	B	BM	C	CA	CB	D	DA	DB	DC	DD	FE	FF	FG	FM	FW	N	S	T	U
Ø 18	80	10	16.5	35	6.5	-	-	M7x1/6	17.5	-	-	-	103	75	-	50	39	M4x7.5	23.5	M3x7	30
Ø 25	100	13	20	45	8.5	7	13	G1/8x8	25.5	14	28	18.5	131	100	50	66	53	M4x8	33	M4x9	42
Ø 32	120	16	20	55	8.5	7	13	G1/8x8	32	17.5	34.5	21	171	140	70	80	65	M5x10	41	M5x10	52
Ø 40	150	22	24	70	13	9.5	14.5	G1/4x12	37.5	20	42	29.5	220	180	90	97	79	M6x12	51	M6x12	63
Ø 50	180	29	24	85	13	9.5	14.5	G1/4x12	47.5	26	52	37	280	220	110	116	96	M8x16	63	M8x12	78
Ø 63	215	40	30	105	13	11	18.5	G3/8x12	59.5	30	62	44.5	333	280	140	136	113.5	M8x16	78	M8x12	93

Example of order: ZF Ø 25 Guiding cylinder with stroke 100mm

Order number															
3	2	5	0	-	0	0	0	0	0	-	0	1	0	0	Port Standard
3	2	5	0	-	0	0	0	1	-	0	1	0	0	Port Underneath	
3	2	5	0	-	0	0	0	2	-	0	1	0	0	One Side Port	

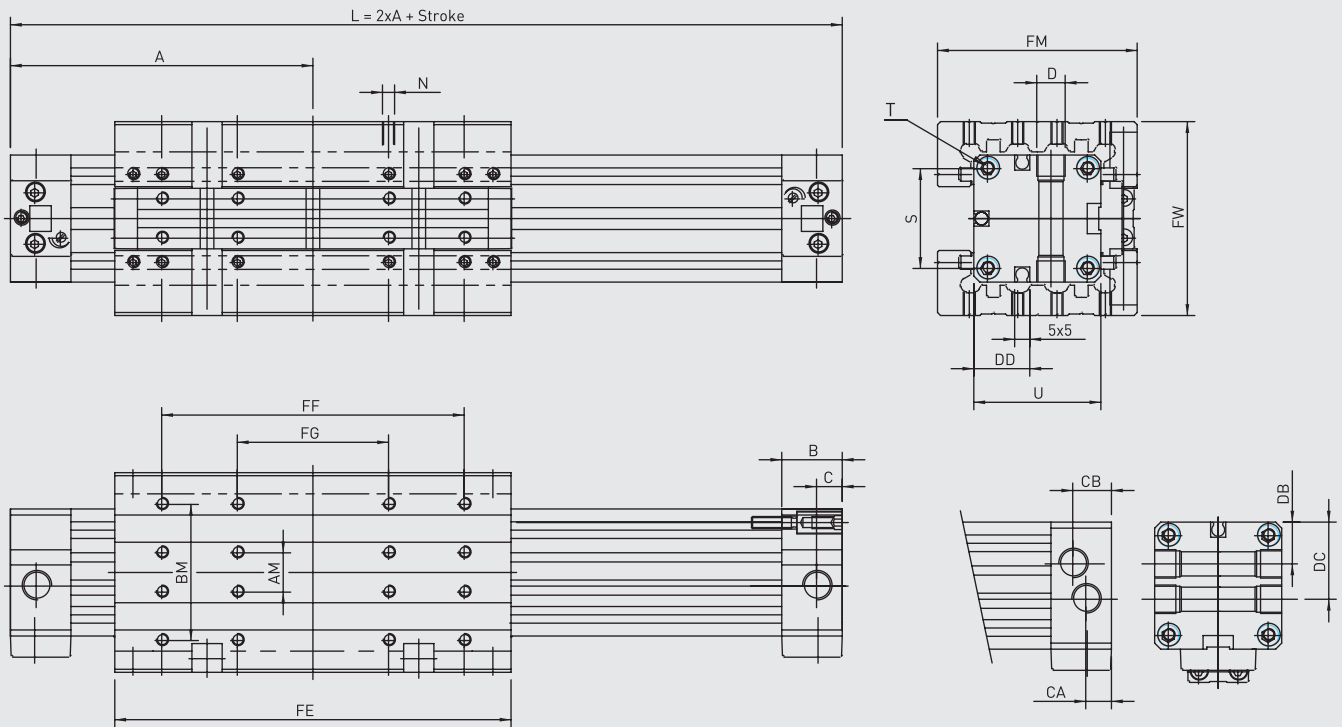

ZFF DOUBLE GUIDING CYLINDER

Ø	A	AM	B	BM	C	CA	CB	D	DA	DB	DC	DD	FE	FF	FG	FM	FW	N	S	T	U
Ø 18	80	10	16.5	35	6.5	-	-	M7x1/6	17.5	-	-	-	103	75	-	50	48	M4x7.5	23.5	M3x7	30
Ø 25	100	13	20	45	8.5	7	13	G1/8x8	25.5	14	28	18.5	131	100	50	66	64	M4x8	33	M4x9	42
Ø 32	120	16	20	55	8.5	7	13	G1/8x8	32	17.5	34.5	21	171	140	70	80	78	M5x10	41	M5x10	52
Ø 40	150	22	24	70	13	9.5	14.5	G1/4x12	37.5	20	42	29.5	220	180	90	97	95	M6x12	51	M6x12	63
Ø 50	180	29	24	85	13	9.5	14.5	G1/4x12	47.5	26	52	37	280	220	110	116	114	M8x16	63	M8x12	78
Ø 63	215	40	30	105	13	11	18.5	G3/8x12	59.5	30	62	44.5	333	280	140	136	134	M8x16	78	M8x12	93

Example of order: ZFF Ø 25 Double Guiding cylinder with stroke 100mm

Order number															
3	2	5	1	-	0	0	0	0	0	-	0	1	0	0	Port Standard
3	2	5	1	-	0	0	0	0	1	-	0	1	0	0	Port Underneath
3	2	5	1	-	0	0	0	0	2	-	0	1	0	0	One Side Port

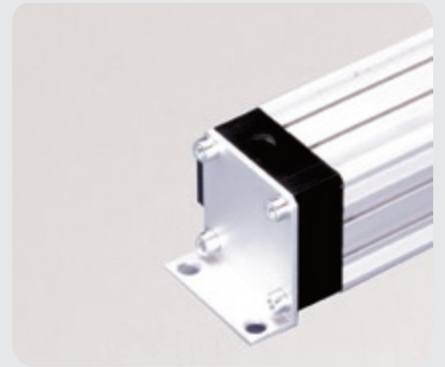
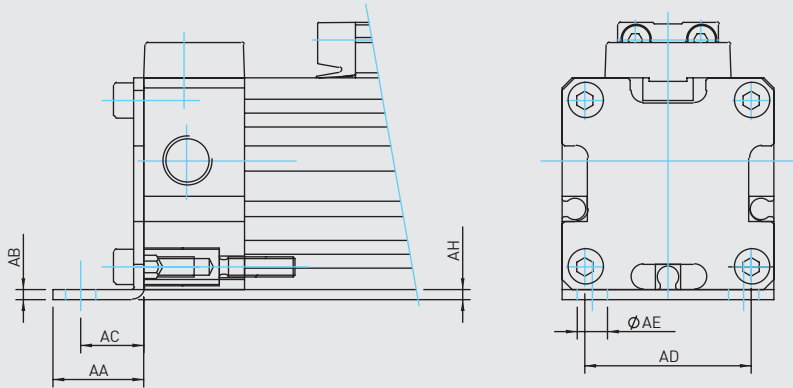

FB MOUNTING BRACKETS

Cylinder Ømm	AA	AB	AC	AD	AE	AH	Order No.
Ø 18	15	2	10	20	Ø 6	2	1182-0001
Ø 25	18	2	12.5	30	Ø 6	2	1252-0001
Ø 32	20	2.5	13.5	40	Ø 7	3	1322-0001
Ø 40	30	3	17.5	50	Ø 9	3.5	1402-0001
Ø 50	28	3	20	60	Ø 9	3	1502-0001
Ø 63	30	3	21	75	Ø 11	4.5	1632-0001

The order No. given includes 2 mounting brackets and 8 screw

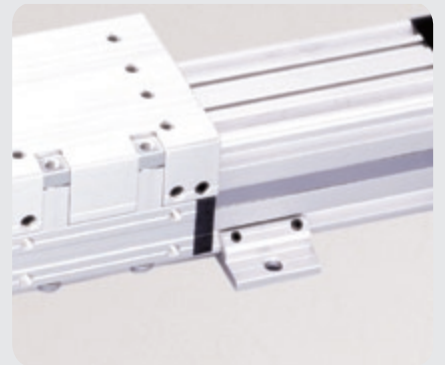
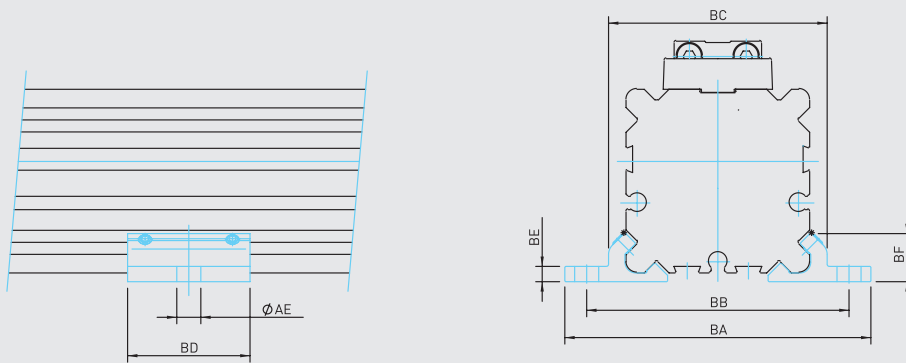

MB MIDDLE SUPPORT

Cylinder Ømm	AE	AH	BA	BB	BC	BD	BE	BF	Order No.
Ø 18	Ø 6	2	56	46	36.5	23	2.5	8.25	1183-0001
Ø 25	Ø 6	2	70	60	50	28	3.5	11	1253-0001
Ø 32	Ø 7	3	85	73	61.5	33	4	13.8	1323-0001
Ø 40	Ø 9	3	105	90	75	38	4.5	16	1403-0001
Ø 50	Ø 9	3	122	106	91	43	5	19	1503-0001
Ø 63	Ø 11	4.5	144	125	107	48	6	22	1633-0001

The order No. given includes 2 mounting brackets and 4 screw

Fz at deflection of 0.5 mm

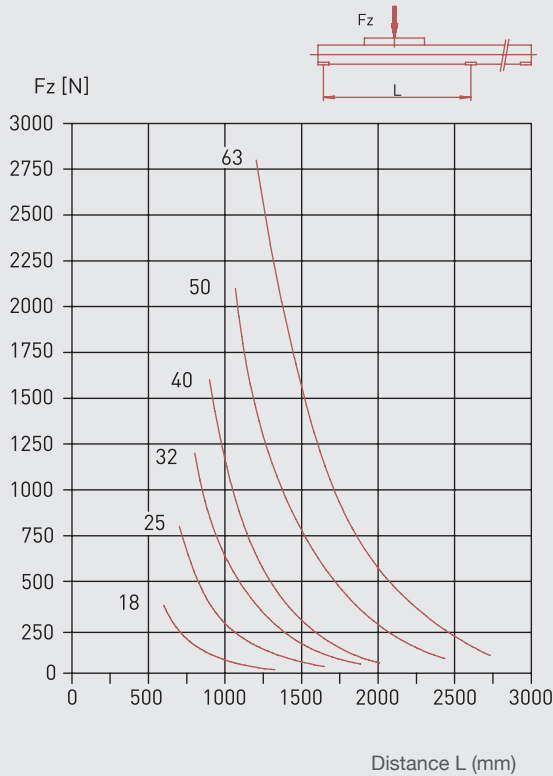

Deflection Diagram

MB Middle Support

When using very long cylinders or applying heavy loads, the tube deflections is to be taken into consideration. One or more middle supports are to be used according to the admissible deflection.

Example:

A cylinder $\text{Ø}25$ should deflect by a maximum of 0.5mm when applying a force F_z of 500N. According to the diagram the cylinder can be 750mm long. Longer cylinders must have a middle support.

Other possibilities:

In case very long cylinders are installed without supports, an additional profile can be used as a support.

Examples:

All versions with middle support and standard profiles.

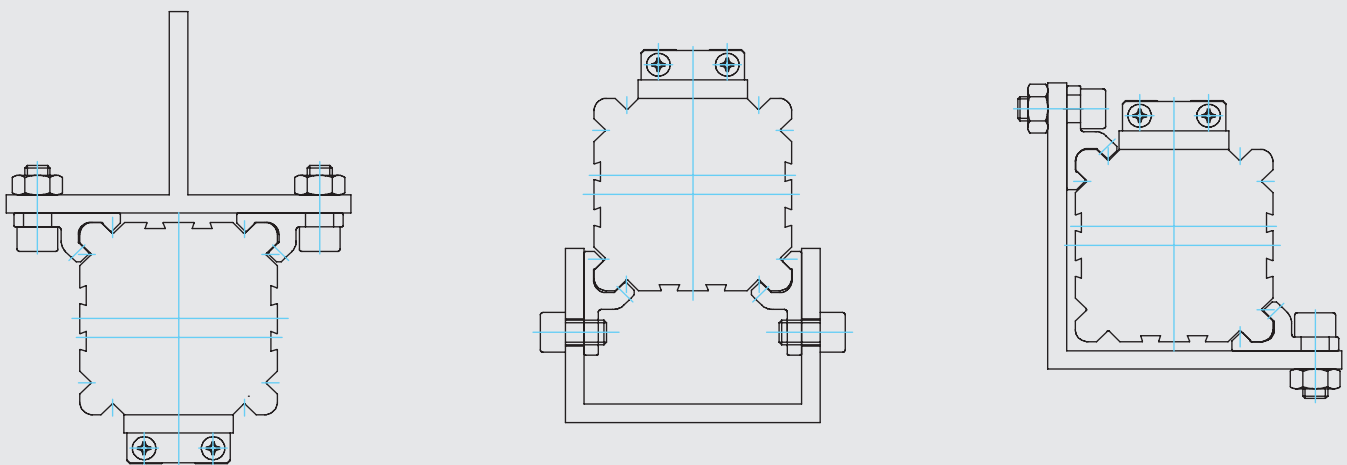

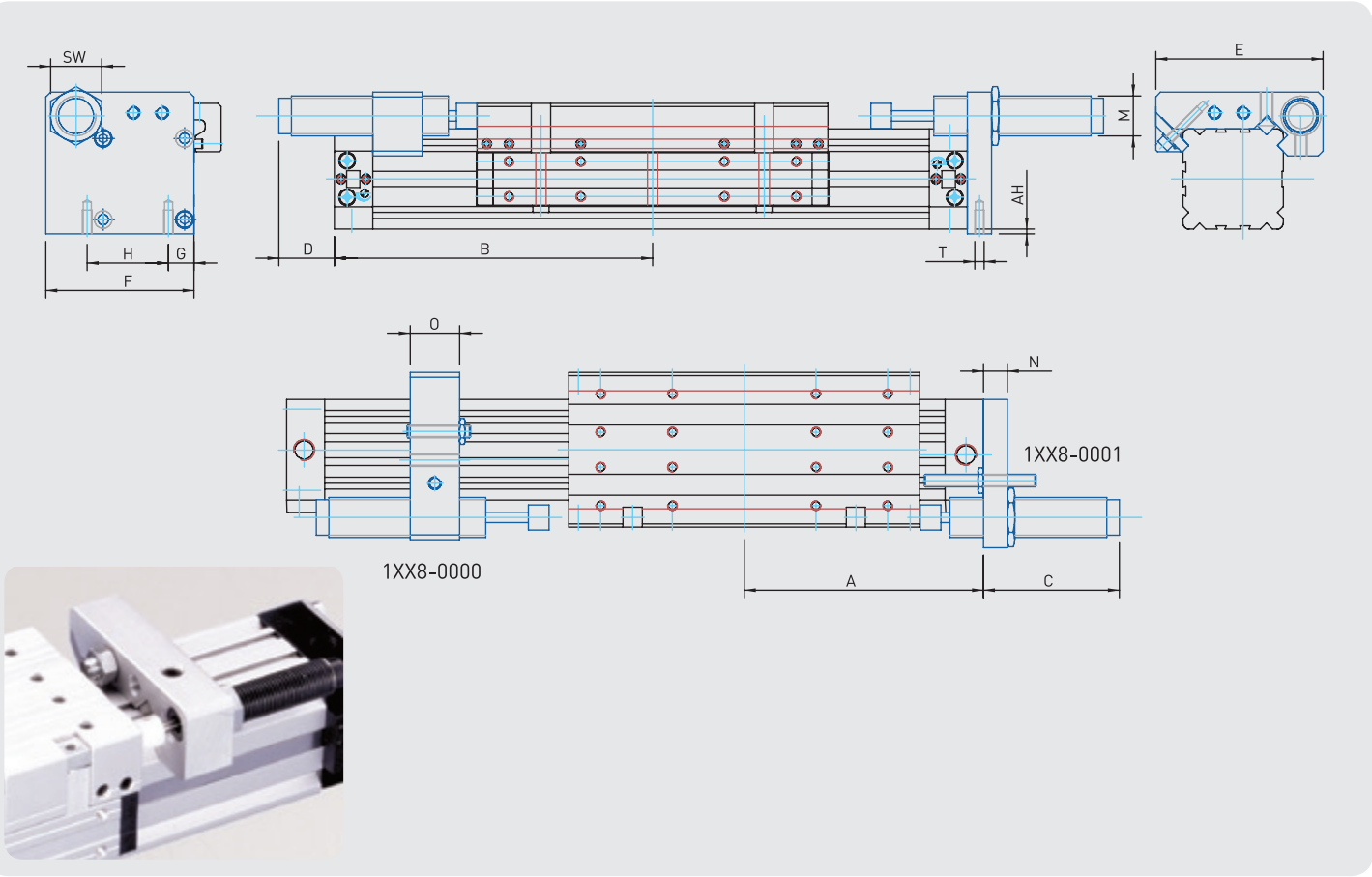

AS STOP ADJUSTMENT

Cylinder Ømm	A ZF/ZFK	AH	B ZF/ZFK	C	D	E	F	G	H	M	N	O	SW	T
Ø 18	80/57.5	2	113/90.5	32	Max. 25	57	43.5	8	23.5	M10x1	8	15	13	M3x10
Ø 25	100/67.5	2	117.5/85	37	Max. 40	72	57	12.5	33	M14x1.5	10	20	17	M4x10
Ø 32	120/77.5	3	135.5/90	70	Max. 30	84	70	14.5	41	M14x1.5	12	20	17	M5x12
Ø 40	150/95	3	165/110	65	Max. 50	105	93	16	51	M25x1.5	15	30	32	M6x15
Ø 50	180/105	3	195/140	80	Max. 65	126	102	22.5	63	M25x1.5	15	30	32	M8x20
Ø 63	215/125	4.5	250/160	80	65	140	118.5	20	78	M25x1.5	15	40	32	M8x20

Example of order: AS25 stop adjustment shiftable ZF25 or ZFK25 (without shock absorbers)

Order No.									
1	2	5	8	-	0	0	0	0	0

**SPECIAL
CYLINDERS
PTR SERIES**





PTR SERIES

Ø32 - Ø100

TWIN RODS CYLINDERS

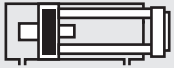

PTR-M: DOUBLE ACTING CYLINDER
WITH CUSHIONING AND MAGNETIC

Example of order:

PTR-M

Product Code

050-0100

Cylinder Ø
Stroke

Force:

Cylinder Ø mm	Rod Ø mm	Thrust and traction forces (6 Bar)	
		Thrust Force (N)	Traction Force (N)
32	8	482	422
40	10	754	660
50	12	1178	1042
63	16	1870	1628
80	20	3016	2638
100	20	4712	4333

Working Fluid :

Filtered and lubricated or filtered and not lubricated air

Operating Temperature Range:

Polyurethane (PU) : (-20°C) - (+80°C)

Viton (FKM) : (-30°C) - (+180°C)

Max. Work Pressure:

10 Bar

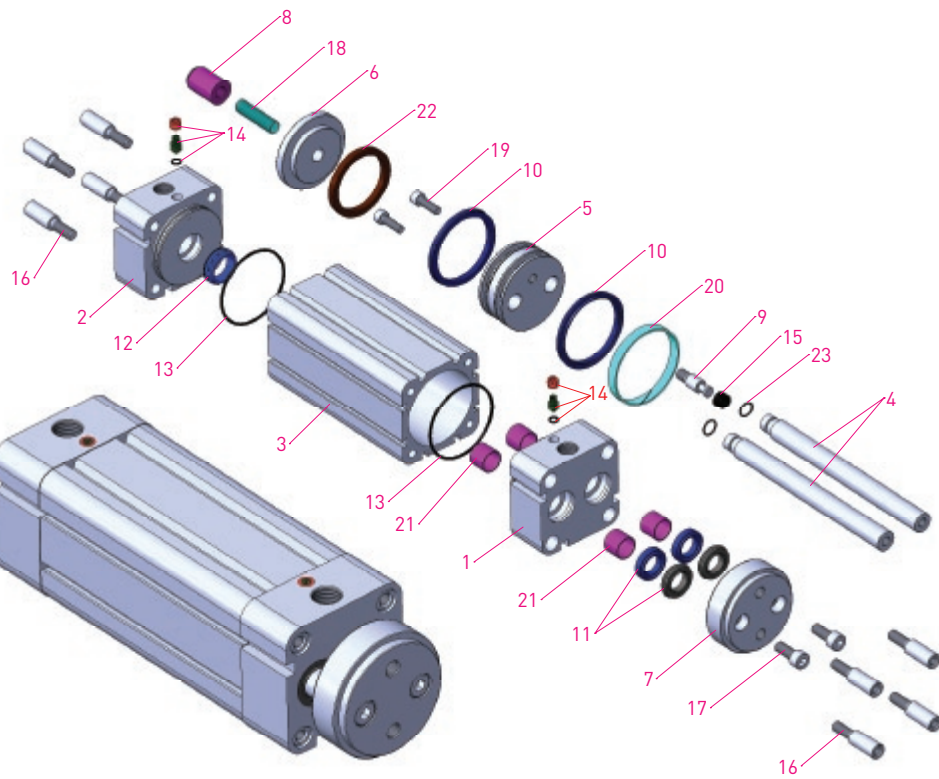
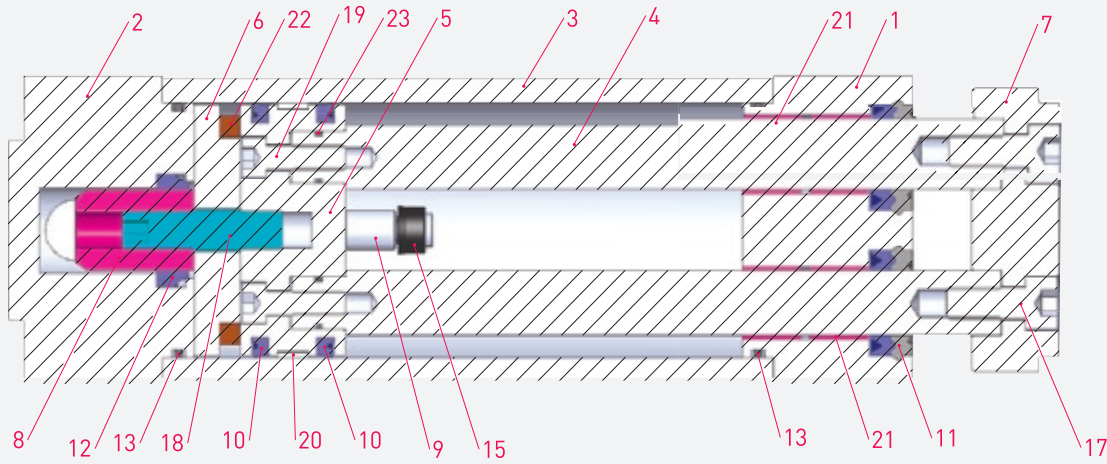

No	MATERIAL NAME	CHARACTERISTIC	PC.
1	Front Head	Aluminium + Eloxac Plated	1
2	Rear Head	Aluminium + Eloxac Plated	1
3	Tube	Al. Mg Si 0,5+Eloxac Plated	1
4	Piston Rod	X20Cr13 Hard Chrome Plated	2
5	Middle Piston	6082 Aluminium	1
6	Magnet Guiding	6082 Aluminium	1
7	Rod and Guiding	Steel + Zinc Plated	1
8	Cushioning Thread	Brass	1
9	Cushioning Pin	Steel + Zinc Plated	1
10	Piston Seal	PU	2
11	Rod Seal	PU	2
12	Cushioning Seal	PU	1

No	MATERIAL NAME	CHARACTERISTIC	PC.
13	Head O-Ring	NBR 70	2
14	Yastıklama vidası	6082 AL.+Eloxac+AISI 303 NBR 70	2
15	Cushioning Pin Seal	NBR 75	1
16	Head Bolt	Zinc Plated Steel	8
17	Rod and Guiding Bolt		2
18	Screw		1
19	Middle Piston Bolt		2
20	Guiding Band		1
21	Guiding Bush	CSB-40	4
22	Magnet		1
23	Rod O-Ring	NBR 70	2

FLM FLANGE MOUNTING

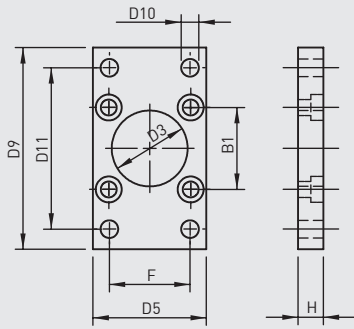

FMTR FLANGE MOUNTING AT REAR

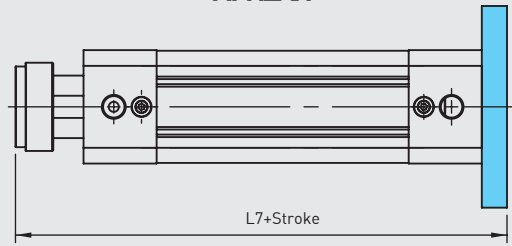

FM FOOT MOUNTING

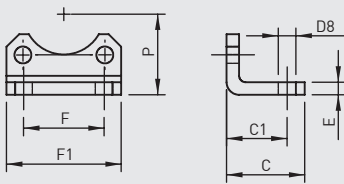

FM FOOT MOUNTING

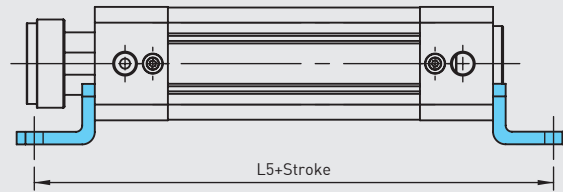

SF SWIVEL FLANGE

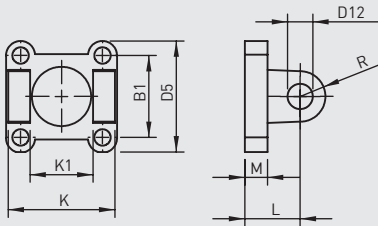

SF SWIVEL FLANGE

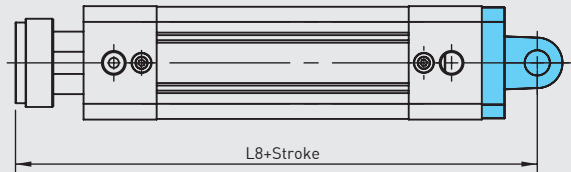

CFM CLEVIS FOOT MOUNTING

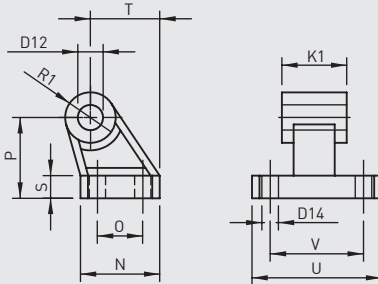

SFWCFM SWIVEL FLANGE WITH CLEVIS FOOT MOUNTING

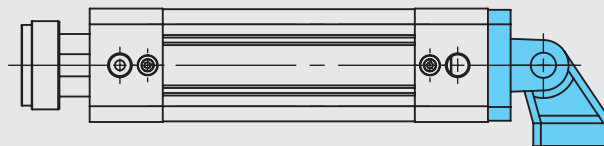

Cylinder Ø mm	B1	C	C1	D3 Ø	D5	D8 Ø	D9	D10 Ø	D11	D12 Ø	D14 Ø	E	F	F1
32	32,5	30	24	30	45	7	80	7	64	10	5,5	5	32	45,5
40	38	37	28	35	54	10	90	9	72	12	5,5	5	36	54,5
50	46,5	41	32	40	65	10	110	9	90	12	6,5	6	45	65
63	56,5	44	32	45	76	10	120	9	100	16	6,5	6	50	76
80	72	56	41	45	94	12	150	12	126	16	9	6	63	94
100	89	58	41	55	112	14	175	14	150	20	9	6	75	112

Cylinder Ø mm	H	K	K1	L	L5	L7	L8	M	N	O	P	R	R1	S	T	U	V
32	10	45	26	22	148	137	149	9	31	18	32	10	10	8	27,5	51	38
40	10	52	28	25	170	153	168	9	35	22	36	12	11	10	30,5	54	41
50	12	60	32	27	180	162	177	11	45	30	45	13	13	12	40,5	65	50
63	12	70	40	32	188	173	193	11	50	35	50	16	15	12	44,5	67	52
80	16	90	50	36	216	190	210	14	60	40	63	16	15	14	57	86	66
100	16	110	60	41	222	196	221	14	70	50	71	20	19	15	65	96	76

**SPECIAL CYLINDERS
H-GUIDING
PNEUMATIC CYLINDERS**

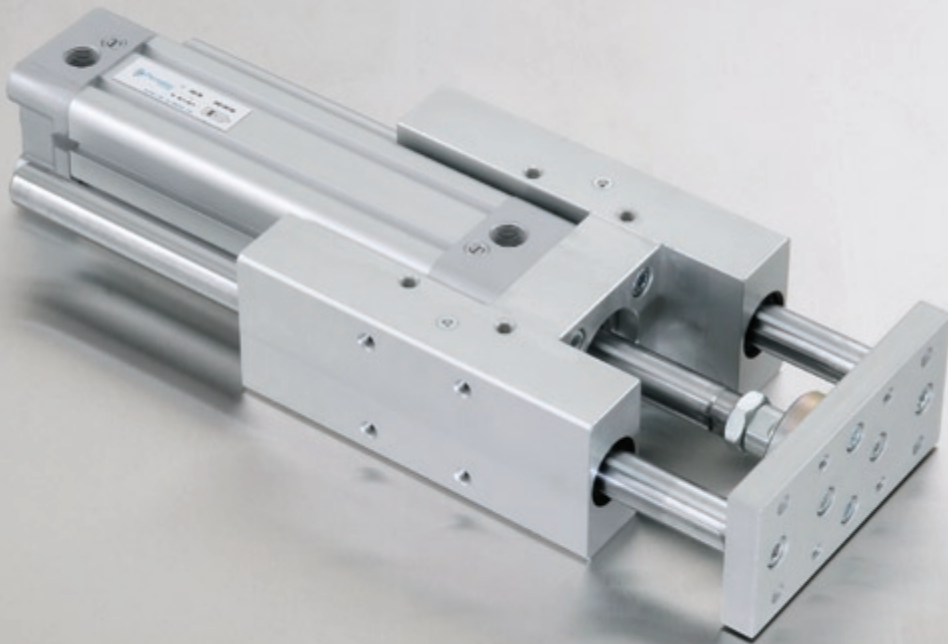



H-GUIDING UNITS

Ø32 - Ø100

BALL BEARING GUIDING

GUARANTEE OF HIGH PERFORMANCE FOR HIGH SPEED SYSTEMS.

SINTER BRONZE GUIDING

PROVIDING THE HIGHEST DURABILITY FOR LATERAL FORCES.

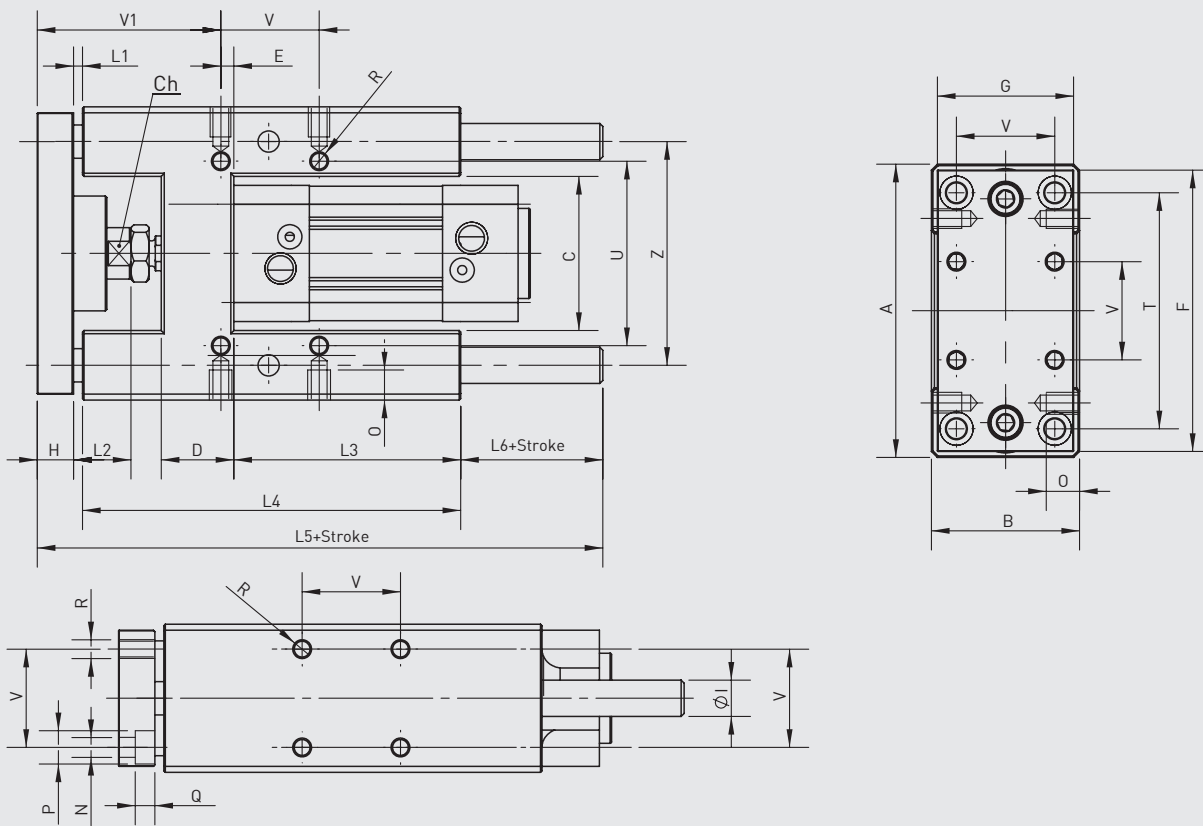

Cylinder Ø mm	A	B	C	Ch	D	E	F	G	H	Ø1	L1	L2	L3	L4	L5	L6	N	O	P	Q	R	T	U	V	V1	Z
32	97	49	51	15	24	4.3	93	45	12	12	3	19	75	125	187	47	6.6	12	11	6.5	M6	78	61	32.5	60.7	74
40	115	58	58.2	15	28	11	112	55	12	16	3	24	80	140	207	52	6.6	12	11	6.5	M6	84	69	38	64	87
50	137	70	70.2	20	34	18.8	134	65	15	20	3	27	78	148	223	57	9	16	15	8.5	M8	100	85	46.5	70	104
63	152	85	85.2	20	34	15.3	147	80	15	20	3	27	106	178	243	47	9	16	15	9	M8	105	100	56.5	74.7	119
80	189	105	105.5	26	50	25	180	100	20	25	3	27	111	195	267	49	11	20	18	11	M10	130	130	72	82	148
100	213	130	130.5	26	55	30	206	120	20	25	3	27	128	218	290	49	11	20	18	11	M10	150	150	89	83	173



H-GUIDING UNITS

Ø20 - Ø25

SINTER BRONZE GUIDING

PROVIDING THE HIGHEST DURABILITY FOR LATERAL FORCES

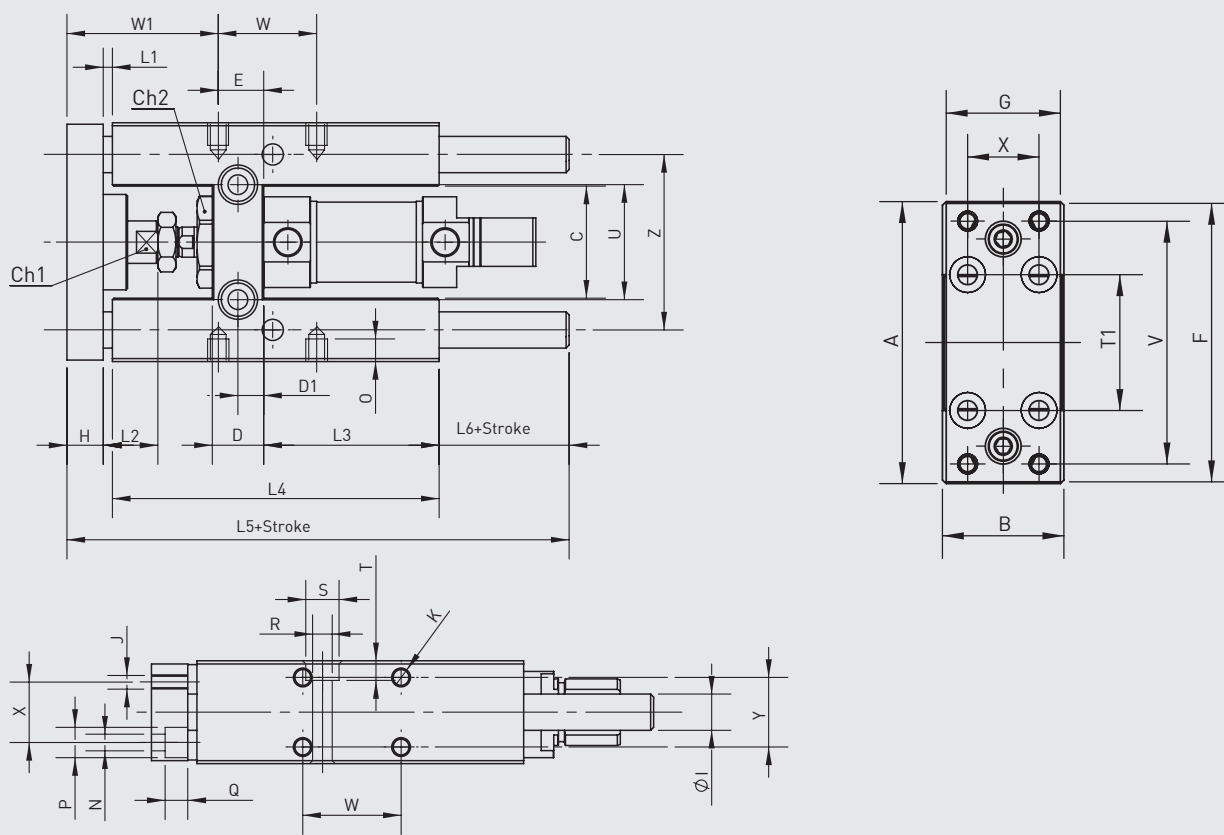

Cylinder Ø mm	A	B	C	Ch1	Ch2	D	D1	E	F	G	H	Ø1	J	K	L1	L2	L3
20-25	79	34	37	12	27	17	8,5	15	78	32	12	12	M5	M6	3	18	58

Cylinder Ø mm	L4	L5	L6	N	O	P	Q	R	S	T	T1	U	V	W	W1	X	Y	Z
20-25	108	166	43	5,5	9	10	7,5	6,5	11	6,5	38	38	68	32,5	50	20	23	58

SPECIAL CYLINDERS
PMS SERIES MINI
PNEUMATIC CYLINDERS





PMS SERIES

Ø16 - Ø25

MINI CYLINDER

POSSIBLE FOR REPAIR AND CHANGING SEALS, BECAUSE OF SCREWED COVERS



PMS: DOUBLE ACTING CYLINDER



PMS-D: DOUBLE ACTING CYLINDER WITH DOUBLE ROD

Example of order:

PMS-D

Product Code

25-0100

Cylinder Ø
Stroke

R1 K4

Variants from
Standard System

VARIANTS FROM STANDARD SYSTEM:

R1: Stainless Steel Piston Rod (SS 304-SS 316)

R4: Stainless Steel Nut for Piston Rod (SS 304)

R5: Piston Rod as CK45 (Hard Chrome Plated)

M1: Extended male Piston Rod Thread

M2: Female Piston Rod Thread

M3: Special Piston Rod Thread

M4: Extended Piston Rod

E2: Stainless Steel Cylinder Covers (SS 304-SS316)

K1: Seals for Max. 150°C (Viton)

K3: Seals NBR

K4: Piston Rod Seal Viton

Force:

Cylinder Ø mm	Rod Ø mm	Thrust and traction forces (6 Bar)	
		Thrust Force(N)	Traction Force (N)
16	8	105	88
20	8	165	141
25	10	266	219

Working Fluid :

Filtered and lubricated air

Operating Temperature Range:

NBR : (-30°C) - (+105°C)

Viton (FKM) : (-30°C) - (+180°C)

Max. Work Pressure:

10 Bar



PMS
Ø16 - Ø25

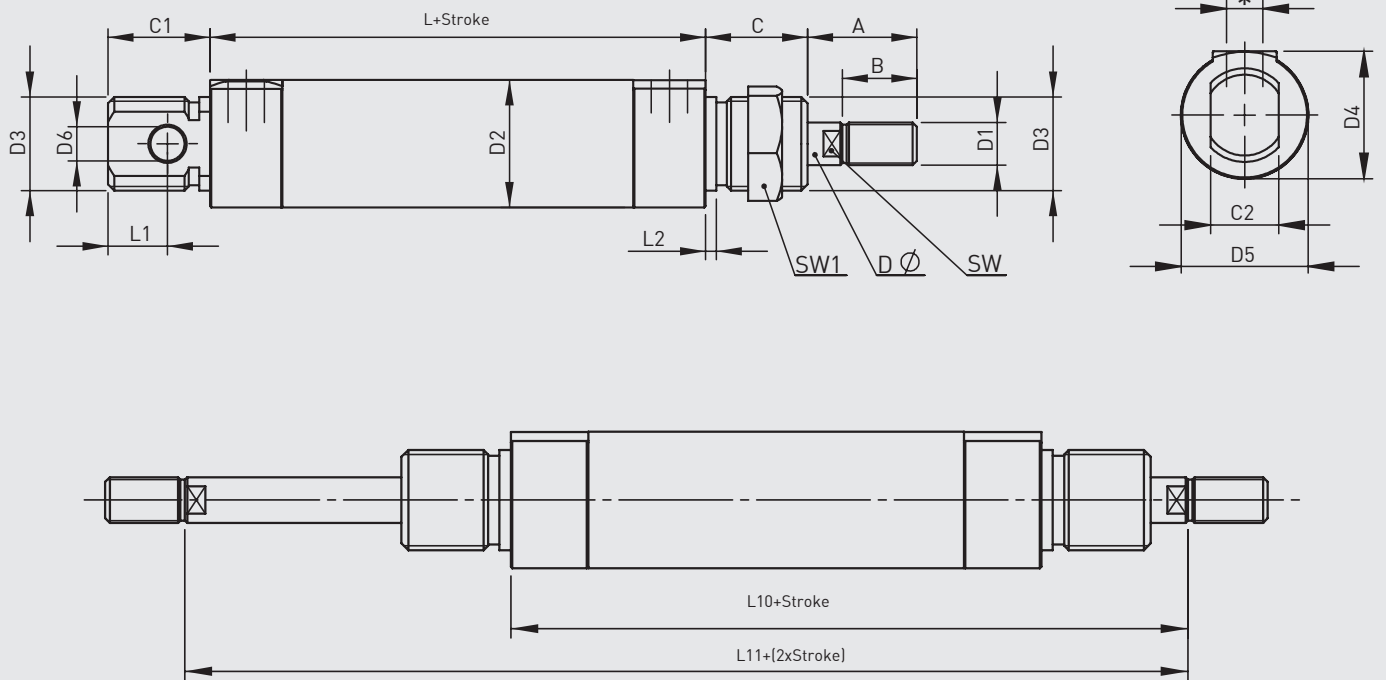

Cylinder Ø mm	A	B	C	C1	C2	D Ø	D1	D2 Ø	D3	D4	D5	D6 Ø	L	L1	L2	L10	L11	SW	SW1	*
16	25	15	22	18	12	8	M8	20	M20x1.5	27	27	6	74	7	2	106	138	7	27	G1/8"
20	25	15	22	22	12	8	M8	25	M20x1.5	27	27	6	72	10	2	104	136	7	27	G1/8"
25	24	18	24	24	16	10	M10	30	M22x1.5	30	27	8	67	14	2	97	127	9	27	G1/8"

TANDEM - CASCADE
CONNECTION ADAPTER
SPECIAL CYLINDERS





TANDEM CYLINDERS

APPLY WITH DOUBLE AND TRIPLE TANDEM APPLICATIONS FOR SAME CYLINDER DIAMETER WHERE THE FORCE IS INSUFFICIENT.



CASCADE CYLINDERS

CAN BE USED TO REALIZE VARIOUS DIFFERENT POSITIONS. APPLICATION IS POSSIBLE WITH THE SAME DIAMETER AND VARYING STROKES.



CYLINDERS WITH CONNECTION ADAPTER

ON SAME CYLINDER DIAMETERS IT IS ABLE TO SELECT SAME OR DIFFERENT STROKES. USED FOR REALIZING DIFFERENT POSITIONS.

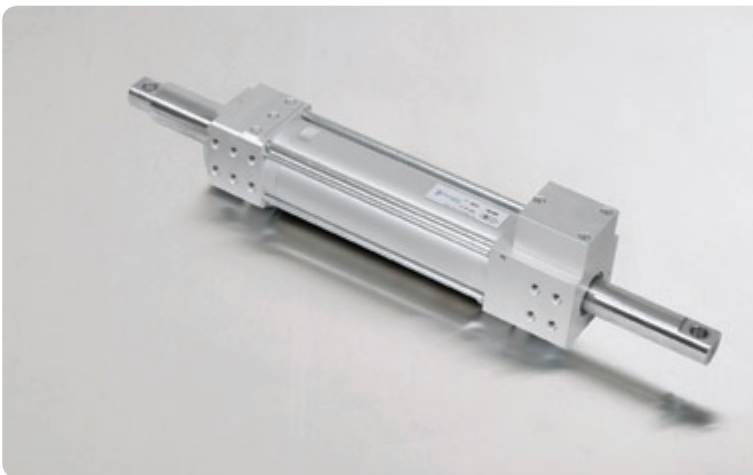

SPECIAL CYLINDERS

SPECIAL CYLINDERS PRODUCED OF CUSTOMER'S REQUIREMENTS.